EASY IS NICE, ON ANY DEVICE

FreemanOnline[®] provides you with all the right tools to ensure a seamless execution at show site, from move-in to move-out. With an enhanced FreemanOnline, we are making it easier than ever for you to get what you want to have a great event.

- Access important show information
- Track freight
- Receive notifications
- Receive assistance through Concierge Services while at show site
- Order Freeman products and services pre-show, during move-in and while the show is open
- Expedite the move-out process
- Access invoices after the show

HEALTH AND SAFETY

Stay informed on Products, Services and Resources that will help you plan for a safe return to your next event. [Click Here](#) for our Health and Safety Resources.

BOOTH EQUIPMENT

As part of your contract to exhibit in JCK Las Vegas 2022, each 10' x 10' is furnished with complimentary booth carpet, one-line company identification sign (for Freeman booth packages only), one-time vacuuming of your booth, **(1) 1000 watt electrical outlet (intended to be used to power showcases)**, and one wastepaper basket per company.

Unless otherwise indicated, all exhibitors are required to have a booth structure - either a custom booth (must be approved by show management) or a Freeman booth package.

Booth Structure Approval

You can bring a custom booth display that you own. [View guidelines and restrictions here](#). Please email your custom booth information to jckbooth@reedexpo.com for approval. Custom booth deadline is Friday, April 1, 2022. Please submit to Show Management as soon as possible.

Cost-Effective Exhibitor Booth Packages

JCK Las Vegas has created turnkey packages should you not wish to bring a custom booth display. A reminder: take advantage of the early-bird pricing and order your package by Friday, April 8, 2022 to save 40%. [Please click here to view Packages](#).

Your booth ID sign will be produced using the ID sign list supplied to Freeman by Reed Exhibitions.

Booth carpeting will be provided for exhibitors by Show Management. Please do not submit the Carpet Order Form in the Furnishings & Carpet section unless you would like to order a special carpet other than the one provided. If you choose to install your own carpet, it must be installed on top of the general show carpet. If you order from Freeman, you will be invoiced for any order submitted.

Please see Freeman Package Carpet Removal Form for Custom Booths only if you do not want the color provided.

Show Management will vacuum your booth the night before the show opens. You may order vacuuming for the remaining three days or porter service. If you want to order either of these services, refer to the Cleaning Order Form in the Facilities Services section of the manual.

DISCOUNT PRICE DEADLINE DATE

Order early on [FreemanOnline](#) to take advantage of advance order discount rates, place your order by **Monday, May 9, 2022**.

SHOW COLORS

Pavilion

Booth Carpet

Level 1 - Hall G:

Essentials & Tech	Black
First Look	Black
Gallery - Level 1 (Hall G Foyer)	Multi Color/Facility
Hong Kong	Black
Passport	Black
Retail Innovation	Black

Level 2 - Halls A, B, C:

Bella Italia, Germany, Spain, Greece	Black
Bridal	Black
Bridge	Black
Clockwork	Black
Currents	Black
Design Collective	Gray
Diamond Plaza	Black
Gallery - Level 2	Black
Lab Grown Diamonds	Black
Plumb Club	Gray

Level 2 - Hall D:

GEMS (including Fine Gems and ICA)	Black
--	-------

*** Carpet colors may change at discretion of show management. ***

Should you wish to order a custom booth, please email JCKexhibits@freeman.com.

Please see Freeman Package Carpet Removal Form if you do not want the color provided as listed above.

Show Management will vacuum your booth the night before the show opens. You may order vacuuming for the remaining three days or porter service. If you want to order either of these services, refer to the Cleaning Order Form in the Facility Services section of the manual.

EXHIBITOR FREQUENTLY ASKED QUESTIONS

For more information and helpful hints on products and services, ordering and invoicing, shipping your freight, and other top questions, please visit [FreemanOnline's FAQ page](#).

FREEMAN ONLINE®

Take advantage of discount pricing by ordering online at [FreemanOnline](#) by **Monday, May 9, 2022**. Using the enhanced FreemanOnline, you will enjoy easy access to added features and functions as well as the high caliber of Freeman services you've come to expect — **before, during** and **after** your show.

To place online orders, you will be required to enter your unique Username and Password. If this is your first time to use FreemanOnline, click on the "Create an Account" link. To access Freeman Online without using the email link, visit [FreemanOnline](#).

If you need assistance with Freeman Online, please call Exhibitor Support at (888) 508-5054 Toll Free US and Canada or +1(512) 982-4186 Local and International.

SHOW SCHEDULE

EXHIBITOR MOVE-IN

The times listed below refer to booth installation. Please refer to the Targeted Move-In Floor Plan in the Target Move-In Floor Plan Tab for delivery of booth materials directly to the show.

GEMS

Tuesday	June 7, 2022	8:00 a.m. - 5:00 p.m.	By Target Only
* All exhibitor materials must be tagged for removal (empty storage) by 3:00 p.m., Tuesday, June 7, 2022.			
Wednesday	June 8, 2022	PRODUCT ONLY DAY **	

All exhibits must be completely assembled no later than 5:00 p.m. on Tuesday, June 7, 2022.

JCK

Saturday	June 4, 2022	8:00 a.m. - 5:00 p.m.	By Target Only *
Sunday	June 5, 2022	8:00 a.m. - 5:00 p.m.	By Target Only *
Monday	June 6, 2022	8:00 a.m. - 5:00 p.m.	By Target Only
Tuesday	June 7, 2022	8:00 a.m. - 5:00 p.m.	By Target Only
Wednesday	June 8, 2022	8:00 a.m. - 5:00 p.m.	By Target Only
Thursday	June 9, 2022	PRODUCT ONLY DAY **	

* Overtime rates will apply.

All exhibits must be completely assembled no later than 5:00 p.m. on Thursday, June 9, 2022.

** What is Product Only Day?

Product Only Day is intended for picking up your product from your armored car carrier, setting up your product displays and attending to last minute details in your booth.

On Wednesday, June 8, 2022 after 5:00 p.m., all crates, containers, ladders and tool boxes MUST be removed and no booth construction will be permitted after this date and time. If these items are not removed by this date and time, they will be tagged as empty and forced in to Access Storage at your expense. Please advise your EACs (subcontractors) regarding this policy.

EXHIBIT HOURS

GEMS

Thursday	June 9, 2022	9:30 a.m. - 6:00 p.m.
Friday	June 10, 2022	9:30 a.m. - 6:00 p.m.
Saturday	June 11, 2022	9:30 a.m. - 6:00 p.m.
Sunday	June 12, 2022	9:30 a.m. - 6:00 p.m.
Monday	June 13, 2022	9:30 a.m. - 4:00 p.m.

JCK

Friday	June 10, 2022	9:30 a.m. - 6:00 p.m.
Saturday	June 11, 2022	9:30 a.m. - 6:00 p.m.
Sunday	June 12, 2022	9:30 a.m. - 6:00 p.m.
Monday	June 13, 2022	9:30 a.m. - 4:00 p.m.

EXHIBITOR MOVE-OUT

Monday	June 13, 2022	4:00 p.m. - 8:00 p.m.
** PLEASE NOTE: NO LABOR IS ALLOWED ON THE JCK SHOW FLOOR 4:00 PM - 6:00 PM		
Tuesday	June 14, 2022	8:00 a.m. - 5:00 p.m.
Wednesday	June 15, 2022	8:00 a.m. - 5:00 p.m.

PLEASE NOTE: Overtime charges for labor will apply Monday through Friday from 5:00 p.m. to 8:00 a.m. and all day on Saturday and Sunday.

DISMANTLE AND MOVE-OUT INFORMATION

- Freeman will begin returning empty containers at 7:00 p.m., Monday, June 13, 2022 and will be finished by 8:00 a.m., Tuesday, June 14, 2022. Many booths will not receive their crates until Tuesday, so please plan your travel accordingly.
- All exhibitor materials must be removed from the exhibit facility by:
 - GEMS:** 8:00 p.m., Monday, June 13, 2022
 - JCK:** 5:00 p.m., Wednesday, June 15, 2022
- To ensure all exhibitor materials are removed from the exhibit facility by the Exhibitor move-out deadline, please have all carriers check-in by:
 - GEMS:** 6:00 p.m., Monday, June 13, 2022
 - JCK:** 1:00 p.m., Wednesday, June 15, 2022
- In the event your selected carrier fails to show on final move-out day, Freeman reserves the right to re-route your freight onto another carrier.

POST SHOW PAPERWORK AND LABELS

Exhibitor Support will gladly prepare your outbound Material Handling Agreement and labels in advance. Complete the Outbound Shipping form and your paperwork will be available at show site. Be sure your carrier knows the company name and booth number when making arrangements for shipping your exhibit at the close of the show.

SHIPPING INFORMATION

Warehouse Shipping Address:

Exhibiting Company Name / Booth #
JCK Las Vegas 2022
 C/O Freeman
 6675 W Sunset Rd
 Las Vegas, NV 89118

Freeman will accept crated, boxed or skidded material beginning **Monday, May 2, 2022** at the above address. Material arriving after **Thursday, May 26, 2022** will be received at the warehouse with an additional after deadline charge. Please note that the Freeman Warehouse does not accept uncrated freight (loose, pad-wrapped material and/or unskidded machinery), COD shipments, hazardous materials, freight requiring refrigerated or frozen storage, a single piece of freight weighing more than 5,000 pounds or a single piece of freight beyond the dimensions of 108" H x 93" W. Warehouse materials are accepted at the warehouse Monday through Friday between the hours of 7:00 a.m. - 2:30 p.m. Certified weight tickets must accompany all shipments. If required, provide your carrier with this phone number: (888) 508-5054.

Show Site Shipping Address:

Exhibiting Company Name / Booth #
JCK Las Vegas 2022
 Venetian Expo & Convention Center
 C/O Freeman
 201 Sands Ave
 Las Vegas, NV 89169

Freeman will receive shipments at the exhibit facility beginning **Saturday, June 4, 2022**. Shipments arriving before this date may be refused by the facility. Any charges incurred for early freight accepted by the facility will be the responsibility of the exhibitor. Certified weight tickets must accompany all shipments. If required, provide your carrier with this phone number: (888) 508-5054.

Adherence to your assigned move-in target date is required. Not adhering to your assigned target date will result in delays for your delivering carrier in the marshalling yard, with potential wait time charges from your carrier, and delay the delivery of freight to your booth. Additional charges may apply.

This show will be marshalled. Please refer to the Marshalling Yard Map & Directions.

Please note: Any materials received by Freeman are subject to Material Handling Charges and are the responsibility of the Exhibitor. This also applies to items not ordered through the Official Show Vendors. Refer to the material handling form for charges for the service.

Please be aware that disposal of exhibit properties is not included as part of your material handling charges. Please contact Freeman for your quoted rates and rules applicable to disposal of your exhibit properties.

SERVICE CONTRACTOR CONTACTS / INFORMATION:

FREEMAN

[Contact Us](#)

FREEMAN EXHIBIT TRANSPORTATION

(800) 995-3579 US & Canada or +1(512) 982-4187 Outside the US or +1(817) 607-5183
International Shipping Services or fax (469) 621-5810 or
Exhibit.Transportation@freeman.com

PURCHASE TERMS

Freeman's Terms & Conditions apply to all orders submitted to Freeman for any goods or services, and may be amended without notice. To review the current Terms & Conditions, [click here](#).

EXCESSIVE TRASH AND BOOTH ABANDONMENT

Any excessive trash which consists of display materials, carpet, padding, crates and/or pallets will be disposed of and charged both a handling fee and disposal fee during exhibitor move-in. Excessive booth materials and/or literature left in the booth at the end of the published exhibitor move-out that is not labeled for an outbound shipment will be considered abandoned and deemed as trash. The exhibitor will be charged for the removal and disposal of these items. Charges may include Installation & Dismantle Labor, Forklift & Rigging Labor, and/or Dumpster Fee.

LABOR INFORMATION

If utilizing Freeman labor, please refer to the Installation & Dismantle Labor Order Form to place your order for display labor. Exhibitors supervising Freeman labor will need to pick up and release their labor at the Labor Desk. Refer to the order form under Labor Services for Straight Time and Overtime hours.

ASSISTANCE

We want you to have a successful show. If we can be of assistance, please call Exhibitor Support at (888) 508-5054.

WE APPRECIATE YOUR BUSINESS!

FREEMAN GENERAL INFORMATION

TRANSLATION SERVICE

Freeman is pleased to offer a new service for our international exhibitors that provides quick interpretation and translation in 150 languages. This service will not only interpret for us on a three-way conversation, but also translate emails from customers. To access this service you may contact Exhibitor Support at (888) 508-5054 US & Canada or +1(512) 982-4186 Local & International.

HELPFUL HINTS

SAVE MONEY

Order early on [FreemanOnline](#) to take advantage of advance order discount rates, place your order by Monday, May 9, 2022.

AVOID DELAY

Ship early to avoid delays. Shipments arriving late at show site will cost you money, time and business!

SAFETY TIPS

Use a ladder, not a chair. Standing on chairs, tables and other rental furniture is unsafe and can cause injury to you or to others. These objects are not designed to support your standing weight.

Be aware of your surroundings. You are in an active work area with changing conditions during move-in and move-out. Pay attention. Look for obstacles, and machinery and equipment that are in use.

Keep your eyes open for scooters and forklifts. The drivers of these vehicles may not be able to see you.

Stay clear of dock areas, trucks and trailers. These areas can be particularly dangerous.

Prevent electrical shocks, falling items and damage to materials. Do not attach items or equipment to the drapes or metal framework provided for you booth. This can cause serious injury or damage to materials.

We discourage children from being in the exhibit hall during installation and dismantle. If children are present during installation and dismantle, they must be supervised by an adult at all times.

Freeman does not ship or handle Hazardous Materials. If any materials you are shipping to the event fall into this category, please contact Freeman to be sure that the material will be allowed at the facility and by the association. In addition, if authorized by the facility and the association, you will need to make separate arrangements for the transport and handling of the approved materials, since Freeman will not transport or handle them.

The operation or use of all motorized lifts and motorized material handling equipment for installation/dismantle of exhibits is NOT permitted by exhibitors or by their exhibitor appointed contractors (EACs). Thank you for your cooperation

Call Exhibitor Support at (888) 508-5054 with any questions or needs you may have.

PRODUCT DAY CLEAN FLOOR POLICY

In an effort to ensure a successful show opening for JCK Las Vegas 2022, we are again enforcing the **Clean Floor Policy** this year. If you are working with an exhibit house, please discuss with them how this policy will affect their work schedule.

This will allow our General Service Contractor and our Cleaning Contractor sufficient time to complete the laying of aisle carpet and the overall cleaning of the exhibit hall as well as provide exhibitors the space to complete their booth set up by keeping the aisles clear.

Policy states:

JCK Exhibitors

All exhibitor materials must be tagged for removal (empty storage) by 3:00 p.m. on Wednesday, June 8, 2022.

All exhibits must be fully assembled by 5:00 p.m. on Wednesday, June 8, 2022.

GEMS Exhibitors

All exhibitor materials must be tagged for removal (empty storage) by 3:00 p.m. on Tuesday, June 7, 2022.

All exhibits must be fully assembled by 5:00 p.m. on Tuesday, June 7, 2022.

All crates, containers, ladders and tool boxes MUST be removed and no booth construction will be permitted after this date and time. If these items are not removed by this date and time, they will be tagged as empty and forced in to Access Storage at your expense. Please advise your EACs (subcontractors) regarding this policy.

There will be no exception to this policy. Any crates without empty or access storage labels will be tagged by the floor managers or the General Services contractor and will be removed from the exhibit hall whether they are full or empty. Exhibitors may request crates to be returned to their booth at exhibitors' expense.

Thank you for your cooperation. We look forward to working with you to ensure a successful JCK Las Vegas 2022!

Interested in going green and saving money?

Follow these tips to make sure your sustainable booth strategies are cost-neutral or even cost-saving! Leave an impact on the show floor, not the environment.



1 BEFORE THE SHOW booth structure

Option 1 Multiple Use

Use **Forest Sustainable Certified (FSC)** wood to build your booth and crates.

Get creative! Design your booth with a **small shipping footprint** to minimize carbon emissions. Freeman's eye-catching stretch-fabric booth designs pack up small (and light!) for shipping.

Option 2 One-time Use

Rent locally from nearby Freeman offices to reduce both shipping costs and carbon emissions.

2 carpet

Option 1 Rent

Rent rather than buy carpet to save on shipping, cleaning, and storage. Freeman Classic carpet can be reused at least four times.

Option 2 Color

Use darker-colored carpet, which is easier to reuse and recycle. Freeman Classic dark-colored carpets are made of 20-50 percent recycled content.



3 shipping

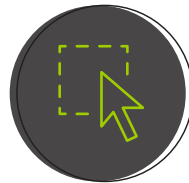

Online + before deadline = better bottom line. Take advantage of early-bird pricing and consolidate shipping when ordering supplies.

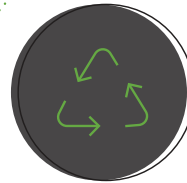

Choose reusable shipping padding. Avoid packing peanuts and foam plastic materials that never decompose.



Ship early. Use the 30-day policy to ship materials to the Freeman advance warehouse.

4 graphics

Option 1 Multiple Use

Print on a durable substrate **without dates, event names, or locations.**

Option 2 One-time Use

Print on 100 percent recyclable materials like Freeman Honeycomb and Smartbuild Eco, which are just as cost-effective as PVC.

5 printing



Reduce printing and **go digital** with your booth literature.



Print locally. Supporting local businesses while reducing shipping? It's a win-win.



Print on at least **50 percent post-consumer recycled paper.**

6

ON SITE

save energy



Use Energy Star-rated equipment for audio-visual equipment and monitors.



Power down. Turn off equipment at the end of each day.



Light up your booth with CFLs, LEDs, or other energy-efficient lighting.

8

shipping out

Pack in, pack out.

Leave no traces on show site.

Join a caravan.

If you're shipping directly to another show, ask **Freeman Transportation about joining a caravan** to your next show.

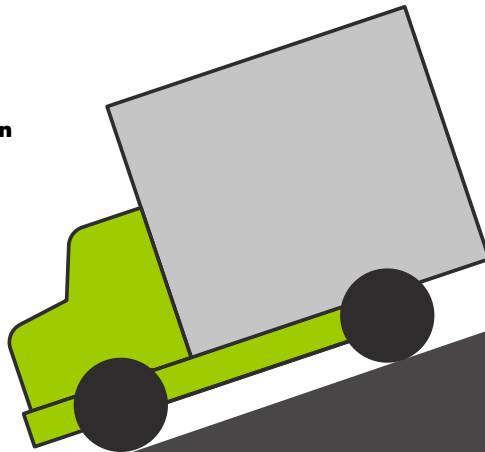

9

leftover materials

Remember to label.

Clearly **label recyclable leftover material** for disposal.

Donate the rest.

Ask the Freeman Exhibitors Services desk about local donation programs.

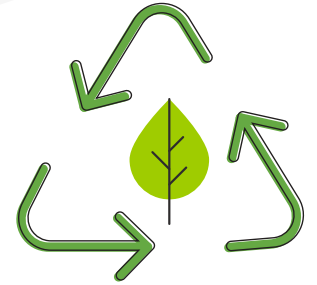

TYPICALLY* DONATE-ABLE

Furniture: Purchased items
Home furnishing: Décor staging materials

Unused raw materials: Plywood, subflooring, non-laminate wood

Flooring: 100 square feet of flooring. Excludes carpet.

Left over giveaways: Pens, pads of paper, sunglasses, USBs, etc., left over in your promotional giveaway

TYPICALLY* RECYCLABLE

Cardboard: Used for signs or shipping boxes

Glass: Green, brown, clear

Plastics: Shrink-wrap or plastic banding used to secure shipments; water/soda bottles; plexiglass (acrylics) clear, smoked, or tinted; Visqueen used to protect flooring

Metal: Aluminum cans/ steel banding

Paper: Fliers, brochures, programs, tickets, office paper, newspaper, magazines, paperboard

Wood: Non-laminate wood



EXHIBITOR AND OFFICIAL SERVICES CONTRACTOR INFORMATION

Show Management has selected Freeman to be the Official Services Contractor for your upcoming show. As the Official Services Contractor, Freeman has the responsibility for material handling and all suspended rigging services not exclusive to Specialized Event Services. We hope this document will assist you in planning for your upcoming event.

To help you understand the Official Services Contractor responsibilities, we ask that you read and observe the following to aid in a smooth and efficient move-in and move-out of the trade show.

Freeman requests that exhibitors do not tip its employees by giving money, merchandise or other special consideration for services rendered. Exhibitors should not give coffee breaks other than mid-morning and mid-afternoon when employees have a fifteen minute paid break. Any attempts to solicit a gratuity by an employee for any service should be reported immediately to a supervisor of Freeman. Freeman employees are paid an excellent wage and tipping is not an accepted company policy.

Freeman craftsmen at all levels are instructed to refrain from expressing any disputes or directly challenging the practices of any exhibitor. All questions arising with regard to the jurisdiction or practices must be directed to a FREEMAN management representative.

PER SHOW MANAGEMENT

TASK	EXHIBITORS MAY	FREEMAN RESPONSIBILITIES
Material Handling	<ul style="list-style-type: none"> As an exhibitor you may "hand carry" material. Hand carry is defined as small items such as cartons and packages that an exhibitor is able to carry. Any mechanical assistance is limited to a small dolly. The assistance of any motorized device or pallet jack is not permitted. When exhibitors choose to "hand carry" they may not access designated material handling areas. Must use specified exhibitor hand carry areas or main entrance of the facility. In all other circumstances items should be considered material handling. <p>In no circumstance is any exhibitor authorized to use Freeman material handling equipment for any purpose.</p>	<ul style="list-style-type: none"> Freeman has been contracted to be the exclusive provider for material handling contract services as ordered by the exhibitor. Freeman has the responsibility to manage all freight docks and to schedule all vehicles into and out of all designated material handling areas for the show. This will assure the smooth, orderly and efficient move in and move out of the tradeshow. Freeman has the sole responsibility for loading and unloading all trucks, trailers, common and contract carriers at its facilities or designated material handling areas. Freeman is not responsible for any material it does not handle. For the convenience of all exhibitors on the show, order forms for material handling services are included in this service manual and are available on Freeman's website at www.freemanco.com/store.
Non-Electrical Hanging Signs	<ul style="list-style-type: none"> Install and dismantle a non-electric sign attached to a booth by the exhibitor's full-time employee or approved EAC. 	<ul style="list-style-type: none"> Assembly and disassembly of hanging signs under 200 lbs. Hanging of non-electrical signs and decorative materials from the ceiling (under 200 lbs).
Booth Installation and Dismantle	<ul style="list-style-type: none"> As an Exhibitor you may choose to utilize your own personnel to set up and dismantle your exhibit. If full-time company personnel are utilized to set an exhibit, they should carry positive company identification, such as a medical identification card or payroll stub. You may hire Freeman to act as your Exhibitor Appointed Contractor (EAC) to perform this work. You may hire an Exhibitor Appointed Contractor (EAC) to perform this work. All EAC's must have the appropriate credentials submitted to Show Management and the facility. 	<ul style="list-style-type: none"> When it comes to installation and dismantling of exhibits, no one does it better than Freeman. With more than 75 years of experience, our group of specialists are ready to assist you with all of your exhibit requests from beginning to end. Whether you choose to supervise or you need the assistance of a full-time Freeman employee, we can meet all your needs, from shipping and storage to emergency on-site repairs to basic installation and dismantling to support service coordination including electrical, furnishings and more. Freeman has the resources and the capabilities to help you have the most successful show experience possible. To secure Freeman labor, please utilize the labor forms enclosed. Skilled Freeman Labor is available to act as your EAC.

For information on services provided exclusively through the Sands Expo & Convention Center (electrical, cleaning, telecommunications, etc.), please contact Specialized Event Services at 702-733-5070.

NAME OF SHOW: **JCK Las Vegas 2022 / June 10-13, 2022**

COMPANY NAME: _____

BOOTH #: _____

CONTACT NAME: _____

PHONE #: _____

E-MAIL ADDRESS: _____

TARGET CHANGE REQUEST

Exhibitors requesting a revised targeted move-in date and time must complete and return this form to Freeman by **May 9, 2022**.

- Scheduled target times are for freight delivery only. Exhibitors may move in once their freight has been delivered to their booth. We HIGHLY encourage you to ship to the advance warehouse.
- All Target Change requests must be authorized by Freeman. Revised target times will be communicated by email.
- Small package shipments sent via UPS, FedEx, and DHL do not require target date changes.
- Freeman will make every attempt to schedule you on the day that you have requested; however, due to the number of requests, we reserve the right to refuse your request.
- We will unload target change requests on a first come basis after originally scheduled targets have been unloaded.

Exhibiting Company _____		Booth Number _____
Primary Contact _____	Telephone _____	Fax _____
Email _____		
Estimated Weight of Materials _____	Estimated Time Required to Set Display _____	
Shipping to: <input type="checkbox"/> Advance Warehouse <input type="checkbox"/> Direct to Show Site		
Please indicate day requested for new target move-in:		
Original Target Date & Time: _____		
Requested Target Date & Time: _____		

**Email Completed Form by
May 9, 2022**

Ron Pickens
Ron.Pickens@freeman.com

For Office Use Only

_____ Approved _____ Denied

New Target Date: _____

New Target Time: _____

Signed: _____

Date: _____

target change request

LAS VEGAS FIRE REGULATIONS

Please find below general guidelines for fire safety. Please refer to the Clark County Department of Building & Fire Prevention website for Requirements and Permit Guidelines, Application Forms, Permit Fees, etc.

Clark County Department of Building & Fire Prevention:

https://www.clarkcountynv.gov/government/departments/building_fire_prevention/index.php

The following items are required to have a permit from the Clark County Department of Building & Fire Prevention:

- Candles and Open Flames (including gelled alcohol, Sterno, etc.)
- Flame Effects
- Open Flame Devices (e.g. candles and gelled alcohol warmers)
- Fireworks/Pyrotechnics
- Compressed Gases
- Cryogenic Fluids
- Hot Works Operations (welding operations)
- Liquid or Gas-Fueled Vehicles or equipment for display in assembly occupancies
- Fire Systems for Covered Booths exceeding 1,000 square feet that will be erected for more than seven (7) show days or contain vehicles, open flame, or hot works.
- Tents and/or Canopies
- Temporary Membrane Structures
- Temporary Outdoor Structures

For information specific to the Las Vegas Convention Center, please contact the LVCVA Convention Services Department at (702) 892-2915.

For information specific to the Mandalay Bay Convention Center, please contact their Exhibitor Services Department at (855) 408-1349.

For information specific to the Sands Expo Center, please contact Sands Customer Service at (702) 733-5070.

PLEASE NOTE: Failure to notify show management and/or apply for permit no later than three weeks prior to the move-in of an event could result in higher permit fees or non-admission of the item/service to the exhibit floor.

- 1. In accordance with the Nevada Clean Indoor Air Act, smoking is prohibited in exhibit areas.**
- 2. All materials used in construction and decoration of an exhibit must be flame retardant.** Fabrics must be certified as flame retardant or a sample must be available for testing. Materials which cannot be treated to meet the requirements may not be used. NFPA 701 is the accepted standard.
- 3. All exits and exit aisles must be kept clear and unobstructed.** No furniture, signs, easels, chairs or displays may protrude into aisles unless shown on the Fire Marshal approved floor plan.
- 4. Designated "No Freight" aisles must be maintained clear of crates and exhibit materials during move-in and move-out.** These aisles are required for emergency access throughout the hall and to expedite freight and empty crate moving.
- 5. All empty cartons or crates must be labeled and removed for storage or they will be removed as trash.** Crates are not to be used as exhibit supports.
- 6. All fire hose racks, fire extinguishers, strobe lights and emergency exits must be visible and accessible (3' clearance for hoses and extinguishers) at all times.** This includes fire protection equipment located within exhibits. Exits and exit signs must not be covered by drapes nor obscured from view by exhibit components.
- 7. Exhibitors who intend to display a vehicle within the confines of their exhibit booth must obtain a vehicle display permit from the Clark County Department of Building & Fire Prevention.** At least one battery cable shall be removed from the battery used to start the engine. (Batteries for auxiliary equipment may be connected.) The fuel tank shall not have more than 1/4 capacity or five (5) gallons, whichever is less. Fuel tank(s) are sealed. Fueling or de-fueling is not permitted in the assembly occupancy. A 36" wide access aisle or clear space is maintained around all sides of the display and a minimum of 20 feet away from exit doors, exit stairs, the exit access or exit passageways. No leaks of fluids. No relocation of the display during exhibit hours.
Exception: Permits are not required at the Las Vegas Convention Center; however, vehicles that use compressed gas are prohibited. At least one battery cable shall be removed from the batteries used to start the vehicle engine. Batteries used to power auxiliary equipment shall be permitted with prior approval from the LVCVA Safety Office.
- 8. Combustible materials must not be stored beneath display vehicles.** Space beneath vehicles must be clear and visible except for permitted electrical supplies.
- 9. Vehicles in building for unloading must not be left with engine idling.** Exhaust gases present extreme hazards to workers on catwalks. If engine cannot be shut down, vehicle must be removed from the building as quickly as possible.
- 10. No storage of any kind is allowed behind booths or near electrical service.** Materials for hand-outs must be limited to one day supply and stored neatly within the booth. Violators will be notified and if not removed by show opening, Official Service Contractor will remove and store at **EXHIBITOR'S EXPENSE**.

LAS VEGAS FIRE REGULATIONS (continued)

11. **All 110 volt extension cords shall be three-wire (grounded), #14 or larger AWG, copper wire. All connections must be supported and secure.** Two wire, "Zip Cords" are not permitted other than factory installed appliance connectors; these may not exceed six (6) feet in length and must be UL approved.
12. **Cube tap adapters are prohibited (Uniform Fire Code 85.107). Multi-plug connectors must be UL approved with built-in overload protection.** Connectors must not be used to exceed their listed ampere rating.
13. **Electrical work under carpets or flooring must be installed by the official electrical service provider.** All cords must be flat, three conductor, #14 AWG or larger.
14. **All temporary wiring must be accessible and free from debris and storage materials.** Hard backed booths must have power supplies dropped within the booth.
15. **Compressed gas cylinders, including LPG, must obtain a permit from the Clark County Department of Building & Fire Prevention.** Flammable gases, i.e.: butane, propane, natural gas, et al; are subject to prior approval. Non-flammable compressed gas cylinders must be secured in an upright position with gauges and regulator protected against physical damage.

Exception: Please contact the Las Vegas Convention Center for their specific guidelines.

16. **Certain halogen lamps have been banned at the Las Vegas Convention Center, Mandalay Bay Convention Center, Sands Expo Center, and Cashman Center.**

Halogen lamps at the Las Vegas Convention Center, Sands Expo Center and Cashman Center are limited to 75 watts and must be of the sealed variety, which prevents direct handling of the bulb.

Halogen lighting policy at Mandalay Bay Convention Center covers restrictions on stem mounted halogen lighting provided by display contractors and exhibitors for the temporary lighting of exhibit booths. The use of any stem mounted halogen or other fixtures employing a non-shielded halogen bulb is not allowed. In addition, conventional track lighting systems that use any of the approved types of halogen bulbs and that are securely mounted to stable exhibit structures will continue to be allowed. Approved halogen bulbs include: MR 11/16 Covered - Low Wattage, MR 16 Covered - Line Voltage and PAR 14, 16, 20, 30 and 48.

17. **Single-level covered exhibits require automatic fire sprinklers underneath covered areas greater than 1,000 square feet that will be in place for 7 or more show days (not including move-in and move-out days).** Sprinklers are also required when there will be vehicles, open flame, or hot works underneath any covered areas. The permit that is required is only for the installation of fire sprinklers, not for structural review of exhibits.

Exception: Where the booth is used in an event with duration less than 7 calendar days and does not contain vehicles, open flame or hot works, automatic fire sprinklers are not required, provided the aggregate area of unsprinklered booths within the room does not exceed 30% of the room size.

Exception: Please contact the Las Vegas Convention Center, Sands Expo Center or Cashman Center for their specific guidelines.

18. **Please note: These are Clark County Department of Building & Fire Prevention guidelines. Please contact the the event facility for specific guidelines.**

Multi-level covered exhibits require automatic fire sprinklers underneath all covered areas on each level when the walking surface of the upper level(s) is over 1,000 square feet that will be in place for 7 or more show days (not including move-in and move-out days). Upper level areas of multi-level exhibit booths exceeding 300 square feet shall not have less than two remote means of egress. Sprinklers are also required when there will be vehicles, open flame, or hot works underneath any covered areas. The permit that is required is only for the installation of fire sprinklers, not for structural review of exhibits. Any exhibit with an upper deck area to be occupied must be evaluated and stamped by a licensed engineer. The upper level of multi-level exhibit booths exceeding 300 square feet shall have not less than two remote means of egress. Stamped plans should be present within the exhibit for potential verification by the Fire Marshal upon request.

Exception: Where the booth is used in an event with duration less than 7 calendar days and does not contain vehicles, open flame or hot works, automatic fire sprinklers are not required, provided the aggregate area of unsprinklered booths within the room does not exceed 30% of the room size.

19. **Tents in excess of 400 square feet, canopies in excess of 700 square feet, and temporary membrane structures must be approved by the Clark County Department of Building & Fire Prevention.**

Exception: Please contact the Las Vegas Convention Center for their Tents/Canopies guidelines.

20. **Demonstration cooking and food warming in exhibition spaces shall comply with the Clark County Fire Code and facility regulations.**

Exception: Please contact the Las Vegas Convention Center for their specific guidelines.

21. **The use of candles and other open flame decorative devices must be approved by the Clark County Department of Building & Fire Prevention.**

Exception: Please contact the Las Vegas Convention Center for their specific guidelines.

PAYMENT INFORMATION

Freeman only accepts payment information electronically. Place your order on [FreemanOnline](#) or follow the steps below to provide your payment information electronically and submit your order forms.

Freeman will no longer accept cash payments for any Freeman services.

1. Submit your payment information

Proceed to our electronic Freeman Pay site to securely submit your payment information

<https://www.freemanpay.com/508986>

2. Submit your order

Upload your order forms through the same link used to submit your payment information

- **Both your order and your payment must be received by the discount price deadline date to guarantee discount pricing.**
- **Orders received without payment or after the discount price deadline date will be charged at the standard price.**
- **Copies of invoices may be picked up from the Freeman Service Center prior to show closing.**

before event

during the event

after event

from your location
or previous event

to your location
or next event

event venue

venue
dock

your exhibit

venue
dock

**advance
warehouse**

storage for empty containers



advance warehouse

where exhibit materials are stored before an event



shipping

transport to the venue's shipping dock then from the shipping dock to the next event or customer location



material handling

move items from the dock, to the exhibit, back to the dock after the show

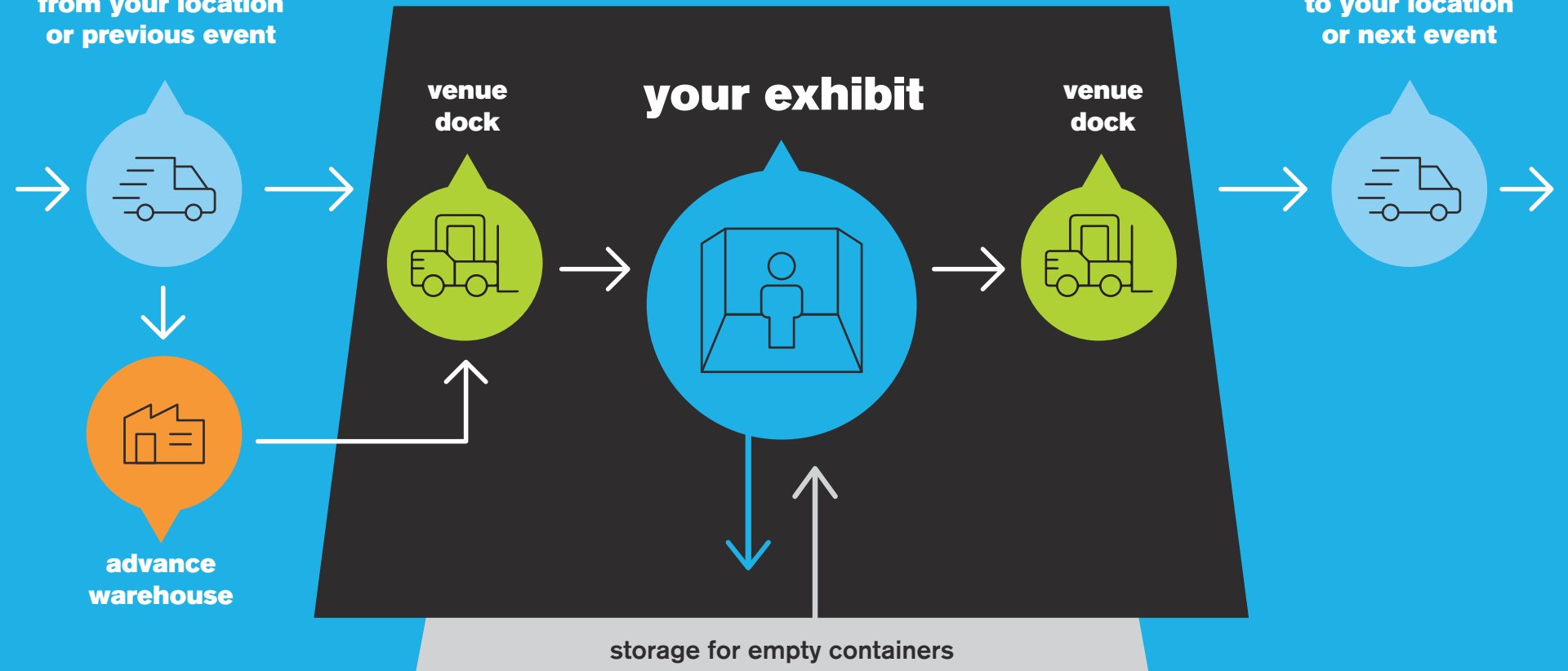

THE WORLD WITHIN REACH

From pre-event planning to on-site execution, Freeman delivers. No matter where you're showing next, Exhibit Transportation from Freeman offers hassle-free delivery options as a seamless extension of the services we provide in all stages of the exhibition process. For an exhibitor, there's nothing quite like arriving at your show site with set-up ready to go. So pack your carry-on bags and leave the rest to us.



Call customer service at the number listed on the Quick Facts. For fast, easy ordering, go to freeman.com

PREFERRED INTERNATIONAL FREIGHT FORWARDER

As the official service contractor, Freeman makes it easier for you to transport your exhibit to the show and on to its next destination, anywhere in the world. With reliable, flexible and cost-effective freight solutions that deliver your exhibit properties where they need to be, when they need to be there, logistical headaches are a thing of the past.

Freeman Exhibit Transportation is an EPA Smartway Partner and is dedicated to reducing carbon emissions related to the transportation of goods.

Renting or shipping items locally saves on carbon emissions and your shipping footprint.

The Freeman Exhibit Transportation promise:

- // ONE CONVENIENT INVOICE ENCOMPASSING ALL FREEMAN SHOW SERVICES
- // ON-SITE TRANSPORTATION EXPERTS ARE AVAILABLE BEFORE, DURING AND AFTER THE SHOW
- // RELIABLE CUSTOMER SERVICE SEVEN DAYS A WEEK, OFFERING COMPLETE SHIPMENT VISIBILITY AND EXPERT SUPERVISION

Freeman can help you with your exhibit material movement across the world. We are proud to offer the following services:

- Local pickup and delivery of exhibit materials
- Global transportation of exhibit goods/materials
- Import customs clearance
- ATA Carnet entries
- Food and Drug Administration clearances
- Federal Communications Commission clearances
- Storage
- Inbound domestic forwarding
- Outbound forwarding
- Outbound customs clearance

Questions?

For more information regarding our services, rates, shipment deadlines, documentation requirements, ordering and the terms and conditions of our service offerings, please visit freeman.com

International Exhibitors: Contact our exhibit transportation experts at **+1.817.607.5183** or via email at international.freight@freeman.com

Continental U.S. Exhibitors: Contact our exhibit transportation experts at **800.995.3579** or via email at exhibit.transportation@freeman.com

DON'T FORGET ABOUT INBOUND SHIPPING! COMPLETE AND SEND THE ORDER FORM TO ORDER YOUR INBOUND AND OUTBOUND SHIPPING.

NAME OF SHOW: **JCK Las Vegas 2022 / June 10-13, 2022**

COMPANY NAME: _____ BOOTH #: _____

CONTACT NAME: _____ PHONE #: _____

E-MAIL ADDRESS: _____

INTERNATIONAL EXHIBIT TRANSPORTATION

TIPS FOR EASY ORDERING

- Credit card information must be on file prior to pick up, as charges will be included on your show services invoice.
- International Exhibitors remember - Shipments originating from countries other than the U.S. must be cleared through customs. Please call for additional information: **(817) 607-5183**

COMPLETE THE FOLLOWING ITEMS ON THIS FORM:

PICK UP INFORMATION:

Requested Pick Up Date: _____

Shipper Name: _____

Shipper Address: _____

(City) (Province/State) (Postal Code)

(Country)

TYPE OF SERVICE - Choose One

- AIR FREIGHT (Transportation & Customs Clearance)
- OCEAN FREIGHT (Transportation & Customs Clearance)

DESTINATION

- I will be shipping to the **WAREHOUSE**
FREEMAN/Exhibiting Company Name
Hold for: **JCK Las Vegas 2022 - Booth #** _____
6675 W Sunset Rd
Las Vegas, NV 89118

MUST BE DELIVERED BY MAY 26, 2022

- I will be shipping to **SHOW SITE**
FREEMAN/Exhibiting Company Name
JCK Las Vegas 2022 - Booth # _____
c/o FREEMAN
Venetian Expo & Convention Center
201 Sands Ave
Las Vegas, NV 89169

CANNOT BE DELIVERED BEFORE JUNE 4, 2022

SHIPPING INFORMATION

Items to be shipped

Number of Pieces	Weight
___ Crates (wooden)	_____
___ Cartons (cardboard)	_____
___ Cases/Trunks (fiber)(color) _____	_____
___ Skids/Pallets	_____
___ Carpet (color) _____	_____
___ Other _____	_____
___ Total	_____

Size of largest piece: (H) _____ (W) _____ (L) _____

NOTE: Shipments will be weighed and measured prior to delivery.

OUTBOUND SHIPPING

- I would like to schedule my international outbound shipping with Freeman Exhibit Transportation. Please provide me with a SLI/ Commercial Invoice for my shipping instructions and signature. (If you secure your inbound and outbound shipping needs in advance through Freeman Exhibit Transportation, you will receive the SLI/ Commercial Invoice for your completion prior to the show move-in date.) Please complete the following information **if different from pick up address:**

Ship to address:

Number of Labels: _____

SEND COMPLETED FORM VIA:
Email: international.freight@freeman.com
 or
Fax: (469) 621-5810

**AN INTERNATIONAL TRANSPORTATION
EXPERT WILL CONTACT YOU TO
CONFIRM RECEIPT OF YOUR SHIPMENT
REQUEST AND FINALIZE DETAILS**

SHOW # _____ 508986 _____

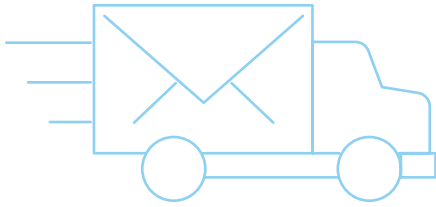

TRANSPORTATION SERVICE, FULLY LOADED.

Our convenient, affordable package puts productivity in overdrive.

Turn to Freeman for one-stop transportation services. Our all-inclusive round trip standard ground shipping and material handling package means transporting materials to any exhibit location has never been easier or more affordable. Plus, Freeman works directly with you and show site decision makers to streamline the process, so it's faster than ever to get on the road to success.

The Freeman Exhibit Transportation promise:

- ALL-INCLUSIVE PRICING WITH NO ADDITIONAL FEES FOR PICKUPS AND DELIVERIES, INCLUDING WEEKEND AND NIGHT SERVICE
- PICK-UP AND TRANSPORTATION FROM POINT OF ORIGIN TO YOUR CHOICE OF EITHER ADVANCE WAREHOUSE OR SHOW SITE
- ON-SITE TRANSPORTATION EXPERTS ARE AVAILABLE BEFORE, DURING AND AFTER THE SHOW
- RELIABLE CUSTOMER SERVICE SEVEN DAYS A WEEK, OFFERING COMPLETE SHIPMENT VISIBILITY AND EXPERT SUPERVISION
- PRE-PRINTED SHIPPING LABELS AND OUTBOUND PAPERWORK

Benefits:

- TURNKEY PRICING ENSURES PRECISE BUDGETING
- NO ADDITIONAL HANDLING, PICK-UP OR DELIVERY FEES
- NO ADDITIONAL FUEL SURCHARGES OR OVERTIME SURCHARGES
- NO CARRIER WAITING TIME FEES
- EXPERIENCED ON-SITE TRANSPORTATION REPS FROM MOVE-IN THROUGH MOVE-OUT
- LTL (LESS THAN TRUCK LOAD) SHIPPING

*Services apply to destinations anywhere in the Continental U.S.



To take advantage, call **1-800-995-3579** or email **exhibit.transportation@freeman.com** for a quote.

RESULTS, DELIVERED

With more than 90 years of experience in the events industry, no one understands exhibit transportation better than Freeman. Our transportation services are a seamless extension of the premium products that exhibitors around the world rely on time and time again.

Between our all-inclusive pricing and superior customer service, Freeman Exhibit Transportation is the most reliable, convenient and cost-effective solution available. Our team of experts has the ability to quickly respond to changes when necessary, remaining entirely responsive to all of your show requirements, whenever and wherever they arise.

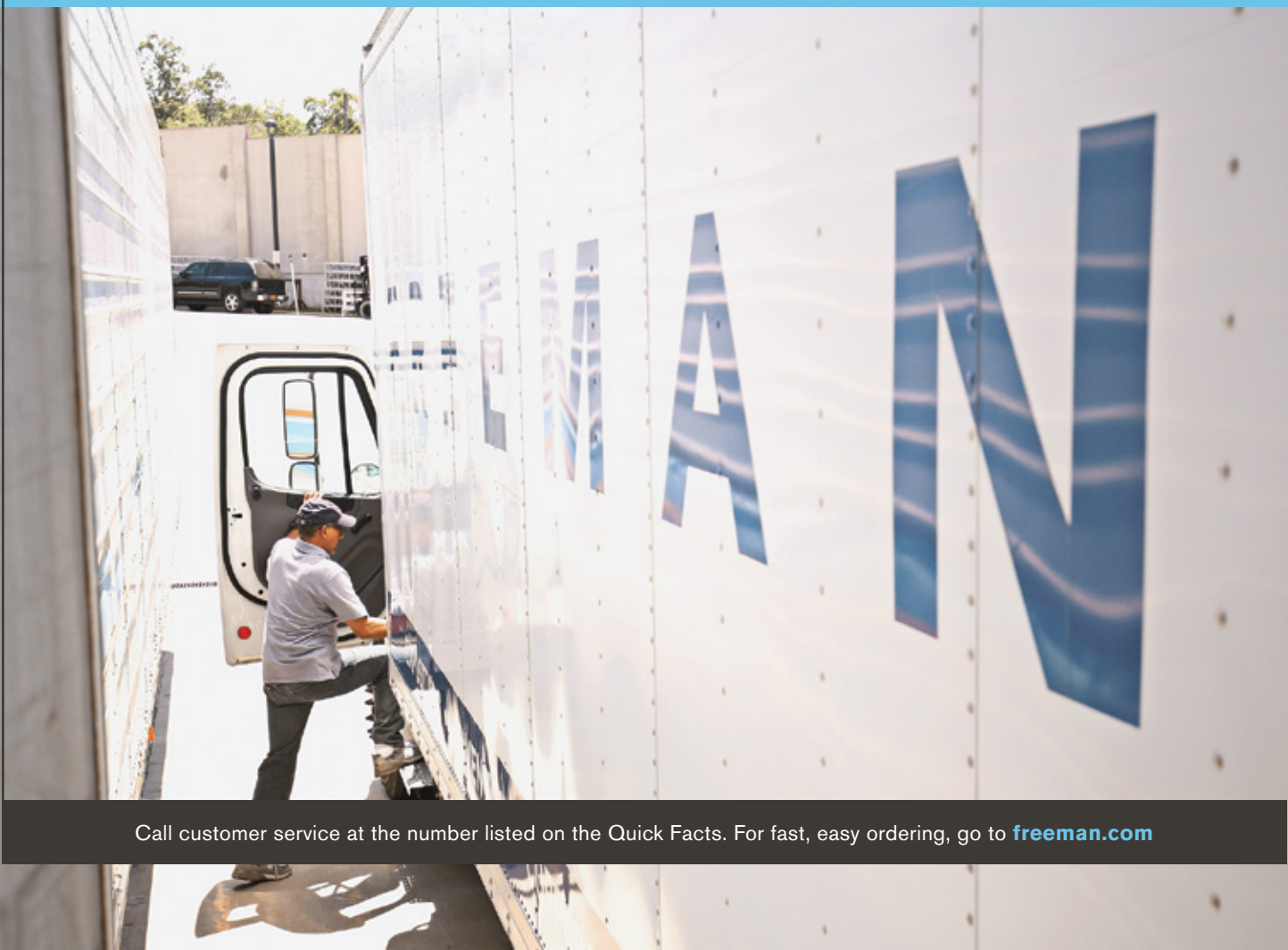

Call customer service at the number listed on the Quick Facts. For fast, easy ordering, go to freeman.com

EXHIBIT TRANSPORTATION SERVICES

Freeman Exhibit Transportation is an EPA Smartway Partner and is dedicated to reducing carbon emissions related to the transportation of goods. Renting or shipping items locally saves on carbon emissions and your shipping footprint.

Freeman Exhibit Transportation promise:

- // ALL-INCLUSIVE PRICING WITH NO ADDITIONAL FEES FOR PICKUPS AND DELIVERIES, INCLUDING WEEKEND AND NIGHT SERVICE
- // ONE CONVENIENT INVOICE ENCOMPASSING ALL FREEMAN SHOW SERVICES
- // ON-SITE TRANSPORTATION EXPERTS ARE AVAILABLE BEFORE, DURING AND AFTER THE SHOW
- // RELIABLE CUSTOMER SERVICE SEVEN DAYS A WEEK, OFFERING COMPLETE SHIPMENT VISIBILITY AND EXPERT SUPERVISION

Questions?

For more information regarding our services, rates, shipment deadlines, documentation requirements, ordering and the terms and conditions of our service offerings, please visit **freeman.com**

Continental U.S. Exhibitors: Contact our exhibit transportation experts at **800.995.3579** or via email at **exhibit.transportation@freeman.com**

International Exhibitors: Contact our exhibit transportation experts at **+1.817.607.5183** or via email at **international.freight@freeman.com**

DON'T FORGET ABOUT INBOUND SHIPPING! COMPLETE AND SEND THE ORDER FORM

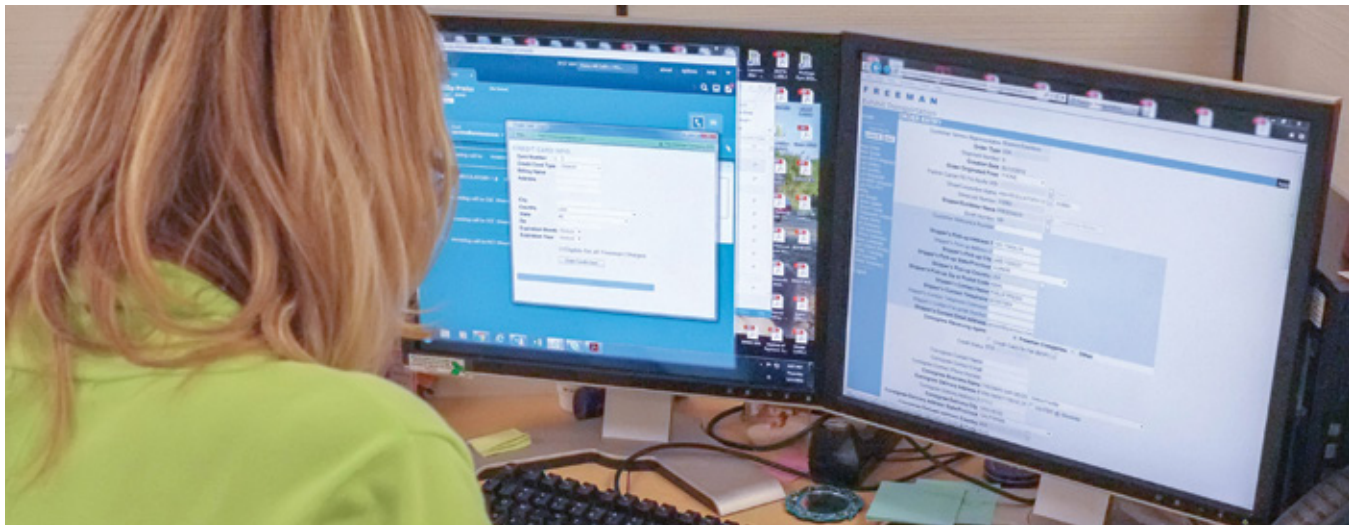

NAME OF SHOW: **JCK Las Vegas 2022 / June 10-13, 2022**

COMPANY NAME: _____ BOOTH #: _____

CONTACT NAME : _____ PHONE #: _____

E-MAIL ADDRESS : _____

For fast, easy ordering, go to www.freeman.com/store.

EXHIBIT TRANSPORTATION

TIPS FOR EASY ORDERING

- Credit card information must be on file prior to pick up, as charges will be included on your show services invoice.
- International Exhibitors remember - Shipments originating from countries other than the US must be cleared through customs. Please call for additional information:
(800) 995-3579 Toll Free US & Canada
(817) 607-5183 Local & International

COMPLETE THE FOLLOWING ITEMS ON THIS FORM:

PICK UP INFORMATION

Requested Pick Up Date: _____

SHIPPER NAME _____

SHIPPER ADDRESS _____

(City) (State) (Zip Code)

DESTINATION

- I will be shipping to the **WAREHOUSE**

FREEMAN / Exhibiting Company Name / Booth #

JCK Las Vegas 2022

C/O: Freeman
6675 W Sunset Rd
Las Vegas, NV 89118

MUST BE DELIVERED BY MAY 26, 2022

- I will be shipping to **SHOW SITE**

FREEMAN / Exhibiting Company Name / Booth #

JCK Las Vegas 2022

C/O: Freeman
Venetian Expo & Convention Center
201 Sands Ave
Las Vegas, NV 89169

CANNOT BE DELIVERED BEFORE JUNE 04, 2022

TYPE OF SERVICE

- Next Day Air: Delivery next business day by 5:00 PM
- Second Day Air: Delivery second business day by 5:00 PM
- 3-5 Day Service: Delivery within 3 - 5 business days
- Declared Value \$ _____

Air Transportation charges are billed by Dimensional or Actual Weight, whichever is greater.

- Standard Ground: Dependent on distance
- Expedited Ground: Tailored to specific requirements
- Specialized: Pad wrapped, uncrated, truck load

SHIPPING INFORMATION

Items to be shipped

Number of Pieces	Est. Weight
___ Crates (wooden)	_____
___ Cartons (cardboard)	_____
___ Cases/Trunks (fiber) (color _____)	_____
___ Skids/Pallets	_____
___ Carpet (color _____)	_____
___ Other (_____)	_____
___ Total	_____

Size of largest piece: (H) _____ (W) _____ (L) _____

NOTE: Shipments will be weighed and measured prior to delivery.

OUTBOUND SHIPPING

- I would like to schedule outbound Freeman Exhibit Transportation. Please provide me with a Material Handling Agreement at show site for my shipping instructions and signature. So we may print your Outbound Material Handling Agreement and labels, please complete the following information **if different from pick up address:**

Ship to address:

Number of Labels : _____

FAX THIS COMPLETED FORM VIA:

E-mail:

exhibit.transportation@freeman.com

or

Fax: (469) 621-5810

A TRANSPORTATION SPECIALIST WILL CALL YOU TO CONFIRM RECEIPT OF SHIPMENT REQUEST AND FINALIZE DETAILS.

SHOW # (508986) _____

WHAT ARE FREIGHT SERVICES?

As the official service contractor, Freeman is the exclusive provider of freight services. Material handling includes unloading your exhibit material, storing up to 30 days in advance at the warehouse address, delivering to the booth, the handling of empty containers to and from storage, and removing of material from the booth for reloading onto outbound carriers. It should not be confused with the cost to transport your exhibit material to and from the convention or event. You have two options for shipping your advance freight — either to the warehouse or directly to show site.

HOW DO I SHIP TO THE WAREHOUSE?

- We will accept freight beginning 30 days prior to show move-in.
- To check on your freight arrival, call Exhibitor Services at the location listed on the Quick Facts.
- To ensure timely arrival of your materials at show site, freight should arrive by the deadline date listed on the Quick Facts. Your freight will still be received after the deadline date, but additional charges will be incurred.
- The warehouse will receive shipments Monday through Friday, except holidays. Refer to the Quick Facts for warehouse hours. No appointment is necessary.
- The warehouse will accept crates, cartons, skids, trunks/cases and carpets/pads. Loose or pad-wrapped material must be sent directly to show site.
- All shipments must have a bill of lading or delivery slip indicating the number of pieces, type of merchandise and weight.
- Shipments received without receipts or freight bills, such as Federal Express and UPS, will be delivered to the booth without guarantee of piece count or condition.
- Certified weight tickets must accompany all shipments.
- Warehouse freight will be delivered to the booth prior to exhibitor set up.

HOW DO I SHIP TO SHOW SITE?

- Freight will be accepted only during exhibitor move-in. Please refer to the Quick Facts for the specific exhibitor move-in dates and times.
- All shipments must have a bill of lading or delivery slip indicating the number of pieces, type of merchandise and weight.
- Shipments received without receipts or freight bills, such as Federal Express and UPS, will be delivered to the booth without guarantee of piece count or condition.
- Certified weight tickets must accompany all shipments.

WHAT ABOUT PREPAID OR COLLECT SHIPPING CHARGES?

- Collect shipments will be returned to the delivery carrier.
- To ensure that your freight does not arrive collect, mark your bill of lading “prepaid.”
- “Prepaid” designates that the transportation charges will be paid by the exhibitor or a third party.

HOW SHOULD I LABEL MY FREIGHT?

- The label should contain the exhibiting company name, the booth number and the name of the event.
- The specific shipping address for either the warehouse or show site is located on the Quick Facts.

HOW DO I ESTIMATE MY MATERIAL HANDLING CHARGES?

- Charges will be based on the weight of your shipment. Each shipment received is billed individually. All shipments are subject to reweigh.
- On the Material Handling Form, locate the rate that applies to your shipment and multiply that rate by the weight of your shipment in pounds.
- The above services, whether used completely or in part, are offered as a package and the charges will be based on the total inbound weight of the shipment.

WHAT HAPPENS TO MY EMPTY CONTAINERS DURING THE SHOW?

- Pick up “Empty Labels” at the Freeman Service Center. Once the container is completely empty, place a label on each container individually. Labeled empty containers will be picked up periodically and stored in non-accessible storage during the event.
- At the close of the show, the empty containers will be returned to the booth in random order. Depending on the size of the show, this process may take several hours.

HOW DO I PROTECT MY MATERIALS AFTER THEY ARE DELIVERED TO THE SHOW OR BEFORE THEY ARE PICKED UP AFTER THE SHOW?

- Consistent with trade show industry practices, there may be a lapse of time between the delivery of your shipment(s) to your booth and your arrival. The same is true for the outbound phase of the show — the time between your departure and the actual pick-up of your materials. During these times, your materials will be left unattended. We recommend that you arrange for a representative to stay with your materials or that you hire security services to safeguard your materials.

HOW DO I SHIP MY MATERIALS AFTER THE CLOSE OF THE SHOW?

- Each shipment must have a completed Material Handling Agreement in order to ship materials from the show. All pieces must be labeled individually.
- To save time, complete and submit the Outbound Shipping Form in advance, or you may contact the Freeman Service Center at show site for your shipping documents.
- Once we receive your outbound shipping information we will create your Material Handling Agreement and shipping labels. If the shipping information is provided in advance, the Material Handling Agreement will be delivered to your booth with your invoice. Otherwise the Material Handling Agreement and labels will be available for pick up at the Freeman Service Center.
- After materials are packed, labeled and ready to be shipped, the completed Material Handling Agreement must be turned in at the Freeman Service Center.
- Call your designated carrier with pick-up information. Please refer to the Quick Facts for specific dates, times, and address for pick up. In the event your selected carrier fails to show by the final move-out day, your shipment will be rerouted on Freeman's carrier choice at the exhibitor's expense.
- For your convenience, approved show carriers will be on site to book outbound transportation if you have not made arrangements in advance.

WHERE DO I GET A FORKLIFT?

- Forklift orders to install or dismantle your booth after materials are delivered may be ordered in advance or at show site. We recommend that you order in advance to avoid additional charges at show site. Refer to the Rigging Order Form for available equipment.
- Advance and show site orders for equipment and labor will be dispatched once a company representative signs the labor order at the Freeman Service Center.
- Start time is guaranteed only when equipment is requested for the start of the working day.

DO I NEED INSURANCE?

- Be sure your materials are insured from the time they leave your firm until they are returned after the show. It is suggested that exhibitors arrange all-risk coverage. This can be done by riders to your existing policies.
- All materials handled by Freeman are subject to the Terms and Conditions, which can be found in the exhibit service manual or online at www.freeman.com.

OTHER AVAILABLE FREIGHT SERVICES

(may not be available in all locations)

- Cranes
- Accessible storage at show site
- Exhibit transportation services (see enclosed brochure)
- Security storage at show site
- Short-term and long-term warehouse storage
- Local pick-up and delivery
- Priority empty return

FREEMAN®

material handling simplified

Our new straight forward pricing makes pre-show budgeting easier. Pay for your actual weight per-pound with no invoice surprises.

- × No minimums
- × No crated
- × No special handling
- × No carpet & pad only
- × No uncrated
- × No hundred-weight billing
- × No reweigh fees
- × No overtime
- × No marshalling yard fees
- × No rounding - pay only for actual weight

It's just easier!



MATERIAL HANDLING

Freeman is the exclusive provider of material handling services. Material handling includes unloading your exhibit material, storing up to 30 days in advance at the warehouse address, delivering to the booth, the handling of empty containers to and from storage, and removing of material from the booth for reloading onto outbound carriers. You have two options for shipping your advance freight - either to the warehouse or directly to show site. Material handling charges will automatically be applied to your account upon receipt of each shipment. It is not necessary to return this form to receive material handling services.

RATES

Material Handling..... \$ **1.11 per pound**
Rate applies to shipments sent to either the warehouse or directly to show site.

Material Handling - 10 lbs and under **Free of Charge**
This rate is per shipment. A qualifying shipment totals any number of pieces delivered to the same booth, by the same carrier, from the same shipper, on the same day, weighing 10 pounds or less.

IMPORTANT SHIPPING INFORMATION

Freeman Exhibit Transportation offers fast and easy service! Please call (800) 995-3579 to have one of our representatives help arrange all your shipment needs.

Warehouse:

- Avoid wait times at show site; ship to our warehouse!
- Freeman will accept shipments at the Warehouse from **Monday, May 2, 2022 thru Thursday, May 26, 2022.**
- Warehouse hours are 7:00 a.m. to 2:30 p.m., Monday through Friday, holidays excluded.
- Warehouse address: Exhibiting Company Name / Booth #
JCK Las Vegas 2022
C/O Freeman
6675 W Sunset Rd
Las Vegas, NV 89118
- Please note that the Freeman warehouse does not accept uncrated freight (loose, pad-wrapped material and/or unskidded machinery), COD shipments, hazardous materials, freight requiring refrigeration or frozen storage, a single piece of freight weighing more than 5,000 pounds or a single piece of freight beyond the dimensions of 108"H x 93"W.

Show Site:

- Please refer to the Targeted Move-In Floor Plan for your assigned date and time to have your booth materials delivered directly to show site.
- This show will be marshalled. Please refer to the Marshalling Yard Map & Directions.
- Show Site address: Exhibiting Company Name / Booth #
JCK Las Vegas 2022
Venetian Expo & Convention Center
C/O Freeman
201 Sands Ave
Las Vegas, NV 89169
- Adherence to your assigned move-in target date is required. Not adhering to your assigned target date will result in delays for your delivering carrier in the marshalling yard, with potential wait time charges from your carrier, and delay the delivery of freight to your booth. Additional charges may apply.

Outbound:

- Submit your outbound shipping information in advance and we will deliver your paperwork to your booth during the show. If no outbound information is submitted, Freeman reserves the right to return the freight back to the company address on file at the exhibitor's expense.

POV & CART SERVICE

Freeman will provide Cart Service for your event. Cart Service is a feature for Privately Owned Vehicles (POVs) that meet the requirements below.

DEFINITION OF PRIVATELY OWNED VEHICLE:

Privately Owned Vehicles are defined as cars, pick-up trucks, vans and other trucks primarily designed for passenger use, not cargo or freight. Vehicles that do not qualify for this service, or that have material that requires mechanical assistance to unload, will be directed to the Freeman Marshalling Yard.

Workers equipped with a flat cart scooter will assist exhibitors with unloading. Each cart will handle a load approximately 3' wide x 4' long x 3' high. Freight must not exceed 300 lbs. For safety reasons, it will be the judgment of the freight supervisor if the load can go higher than 3 feet. Cart Service includes storage of empty cardboard/product boxes at no additional charge. Empty stickers for your cartons and cases will be provided for this service.

RATES:

This service is available at a round trip rate of \$181.25 per trip (from the dock to the booth and the booth to the dock).

DIRECTIONS:

- To receive this service, proceed directly to the facility and check in at the designated POV Check-In area for staging, checking in, processing paperwork and determining if vehicles are qualified for Cart Service. There will be signage posted to direct you.
- Two people must be with the vehicle - one to accompany the product to the booth and one to remove the vehicle from the area.
- The determination of Cart Service versus Material Handling will be made at the discretion of Freeman management. Any disputes will be handled at the time of unloading.

AVAILABILITY:

Cart Service will be available on the following dates and times:

<u>Move-In</u>			<u>Move-Out</u>		
Tuesday	June 7, 2022	1:00 p.m. - 5:00 p.m.	Monday	June 13, 2022	6:00 p.m. - 10:00 p.m.
Wednesday	June 8, 2022	8:00 a.m. - 9:00 p.m.	Tuesday	June 14, 2022	8:00 a.m. - 12:00 p.m.*
Thursday	June 9, 2022	8:00 a.m. - 9:00 p.m.			

* Please visit the Freeman Service Center to complete and/or submit an Outbound Material Handling Agreement.

Please note: No shipments will be unloaded after 9:00 p.m. on Thursday, June 9, 2022. Please plan adequate time for arrival and unloading at the Venetian Expo & Convention Center.

VEHICLES THAT QUALIFY:



Sedan



SUV



Pickup



Van

VEHICLES THAT DO NOT QUALIFY:



Trailer



Commercial Van



Rentals



Bobtail



Stakebed

POV & CART SERVICE MAP & DIRECTIONS

VENETIAN EXPO & CONVENTION CENTER

The Venetian Expo & Convention Center has a limited amount of space for unloading P.O.V's. In an effort to provide the most efficient service and to help alleviate problems or frustration associated with P.O.V. Services, Freeman has secured a lot (see map) for staging, checking in, processing paperwork and determining if vehicles are qualified for P.O.V. Service. **Please note:** We anticipate that during peak periods wait time for this service can exceed 2-3 hours. We will do everything in our power to eliminate this wait time.

In addition to the limited amount of space available for unloading P.O.V's, the parking for the Venetian Expo & Convention Center at the Venetian Hotel has very limited space for parking large vehicles including those pulling trailers. Please make arrangements prior to arriving in Las Vegas if you plan on bringing a vehicle and trailer.

IMPORTANT

P.O.V service will require one person to remain with the vehicle at all times. If an exhibitor would like to go to the booth while the freight is being unloaded, Freeman will require an additional person to remove the vehicle.

All orders are governed by the Freeman Payment Policy and the Limits of Liability and Responsibility.

P.O.V. SERVICE MAP

Location:

The P.O.V. Staging Area is located at 3845 Pioneer Avenue, Las Vegas, NV 89102.

Directions:

- From I-15 Northbound or Southbound
- Exit Spring Mountain Road West exit.
- Right on South Valley View Boulevard.
- First left onto Pioneer Avenue.
- Lot is on the left.

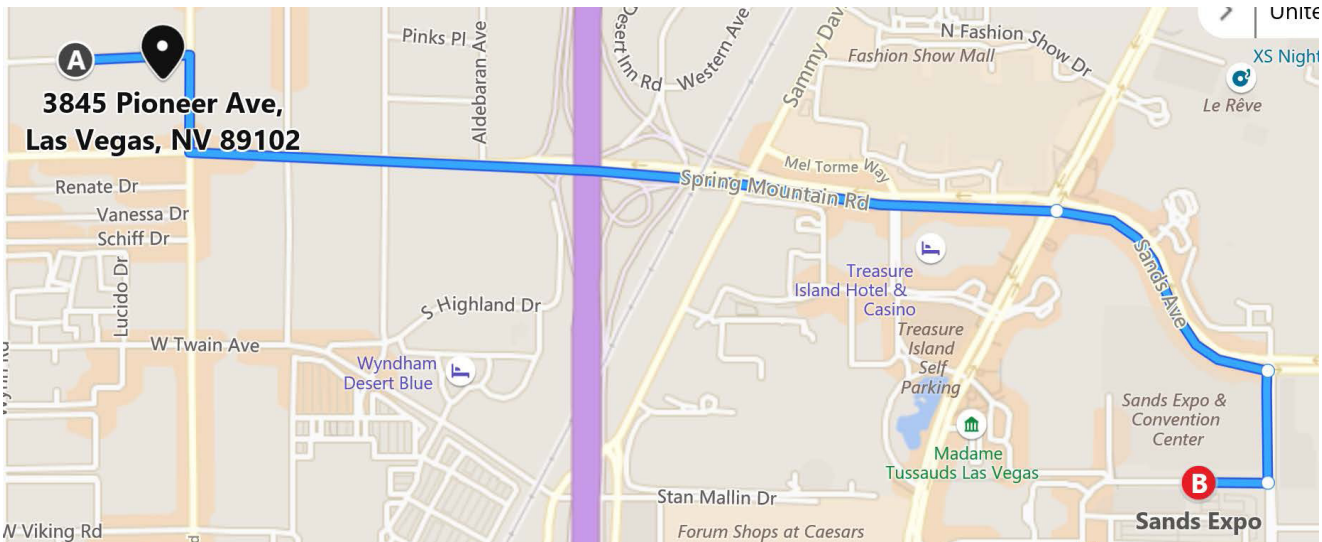

HAND CARRY INFORMATION

Exhibitors may hand carry their own materials into the exhibit space, provided they do not use material handling equipment to assist them. Two-wheel luggage/suitcase is acceptable; hand carts and any four-wheel cart or dolly is prohibited. Access to the loading dock and/or freight doors is prohibited.

If exhibitors want to hand carry their items into the exhibit hall, the only Hand Carry Unload Area is in front of the Venetian Expo & Convention Center, accessible from Sands Avenue, utilizing the glass doors on Level 1.

If you go directly to the freight entrance or loading docks, you will be turned away or charged the published Material Handling rates. Exhibitors are not allowed to unload their own vehicles at the freight entrance or loading docks or drive their own vehicles into the exhibit hall to unload.

Hand carry unloading is provided for exhibitors with a small amount of exhibit product that they need to get in to the exhibit hall. Parking in the Hand Carry Unloading Area is limited to 30 minutes from the time a vehicle enters the area. **Vehicles left beyond 30 minutes will be towed at the Exhibitor's expense.** Only vehicles that qualify (see below) will be allowed in the Hand Carry Unloading Area. Cars, vans, and light trucks may also utilize Freeman's POV Service for a fee. All other vehicles must check in at the Marshalling Yard.

VEHICLES THAT QUALIFY:



Sedan



SUV



Pickup



Van

VEHICLES THAT DO NOT QUALIFY:



Trailer



Commercial Van



Rentals



Bobtail



Stakebed

ADVANCE WAREHOUSE
6675 West Sunset Road
Las Vegas, NV 89118

Hours of Operation:

Warehouse hours are Monday through Friday from 7:00 a.m. to 2:30 p.m., Holidays excluded.

Directions:

From I-15 Northbound or Southbound

Exit 1-215 West
Exit Jones Boulevard (stay in center lanes)
Cross over Jones Blvd staying to the right
Continue on Raphael Rivera Way
Freeman will be on right

From US-93 / I-515 Northbound

Exit I-215 West
Exit Jones Boulevard (stay in center lanes)
Cross over Jones Blvd staying to the right
Continue on Raphael Rivera Way
Freeman will be on right



MARSHALLING YARD
6555 West Serene Avenue
Las Vegas, NV 89139

*This location does not accept deliveries.
This location is only for the staging of trucks delivering to and picking up from show site facilities.*

Please note:

- All carriers delivering to or picking up from the facility must check in at the Marshalling Yard.
- Drivers will be assigned a number according to check-in time and will be dispatched once dock space is available.
- Please be advised that certified weight tickets are required when checking into the Marshalling Yard. For your convenience, Freeman has available a full-size certified scale at the Marshalling Yard. If your driver has valid certified weight tickets, Freeman will accept these tickets and your driver will not have to scale at the Freeman Marshalling Yard.

Directions:

From I-15 Northbound

Exit NV160 W/Blue Diamond Rd
Left onto Blue Diamond Rd
West on Blue Diamond Rd
(approximately 4 miles)
Left on S Torrey Pines Dr
From stop sign at Serene, go straight
Marshalling Yard is directly ahead

From I-15 Southbound

Exit NV160 W/Blue Diamond Rd
West on Blue Diamond Rd
(approximately 4 miles)
Left on S Torrey Pines Dr
From stop sign at Serene, go straight
Marshalling Yard is directly ahead

From US-93 / I-515 Northbound

Exit I-215 West
Exit I-15 South
Merge on NV160 W/Blue Diamond
West on Blue Diamond Rd
(approximately 4 miles)
Left on S Torrey Pines Dr
From stop sign at Serene, go straight
Marshalling Yard is directly ahead





Attn: Lisa Pickens
(702) 579-1802

Lisa.Pickens@freeman.com



PLEASE NOTE: This service is for freight received prior to the published date that advanced warehouse receiving will begin or if the freight will be held for another event after the close of your current show.

storage agreement

OWNER OF MATERIALS

COMPANY NAME:		
ADDRESS:		
CITY:	STATE:	ZIP:
CONTACT NAME:	PHONE #:	
E-MAIL ADDRESS:	FAX #:	

HOLD FOR

SHOW:	FACILITY:	
COMPANY NAME:	BOOTH #:	
ADDRESS:		
CITY:	STATE:	ZIP:
COMMENTS:		

INVOICE TO

COMPANY NAME:		
ADDRESS:		
CITY:	STATE:	ZIP:
CONTACT NAME:	PHONE #:	
E-MAIL ADDRESS:	FAX #:	

DESCRIPTION OF MATERIALS TO BE STORED

NUMBER OF PIECES	DESCRIPTION OF MATERIALS TO BE STORED	WEIGHT	CUBIC FOOTAGE
	CRATES (WOODEN)		
	CARTONS (CARDBOARD)		
	TRUNKS, CASES (FIBER) COLOR: _____		
	SKIDS / PALLETS		
	CARPETS / PADS		
	TOTALS		

RATES AND CHARGES

DESCRIPTION OF CHARGE	RATE (FORMULA)	MINIMUM CHARGE	TOTAL
Short Term Storage (90 days or less)	\$80.25 per cwt (____ cwt @ 8.25 per cwt)	\$82.50 per month	\$
Long Term Storage - Stackable (over 90 days)	\$0.32 per cu ft (____ cu ft @ 0.32 per cu ft)	\$80.00 per month	\$
Long Term Storage - Non-Stackable (over 90 days)	\$0.36 per cu ft (____ cu ft @ 0.36 per cu ft)	\$90.00 per month	\$
Returned Shipment (hold for next show)	\$24.75 per cwt (____ cwt @ 24.75 per cwt)	\$247.50 each way	\$
Returned Shipment (place into storage)	\$31.75 per cwt (____ cwt @ 31.75 per cwt)	\$317.50	\$
Returned Shipment (unload/reload onto carrier)	\$38.75 per cwt (____ hrs @ 38.75 per cwt)	\$387.50	\$
TOTAL			\$

PLEASE COMPLETE THE ACCEPTANCE OF TERMS ON THE REVERSE SIDE.

NAME OF SHOW: **JCK Las Vegas 2022 / June 10-13, 2022**

COMPANY NAME:

BOOTH #:

CONTACT NAME:

PHONE #:

E-MAIL ADDRESS:

PAYMENT TERMS: All accounts must have a valid credit card on file. Storage will be billed on a monthly basis and charges will be placed in full on such credit card at the time of invoicing. Prior arrangements must be made in writing to have invoices billed with a (30) day net and if such payment is not received within (30) days from the invoice date, the full payment will be applied to the credit card on file. Rates are subject to change with (30) days notice to Client. All charges due Freeman for all services must be paid in full prior to the release of materials from storage. Effective 30 days after invoice date, any unpaid balance will bear a FINANCE CHARGE at the lesser of the maximum rate allowed by applicable law, or 1.5% per month, which is an ANNUAL PERCENTAGE RATE of 18%. If any finance charge hereunder exceeds the maximum rate allowed by applicable law, the finance charge shall automatically be reduced to the maximum rate allowed, and any excess finance charge received by Freeman shall be either applied to reduce the principal unpaid balance or refunded to the payer. If Client's account remains in default for (60) days after the date of the invoice, goods may be subject to sale as outlined in this Agreement. In the event of any dispute between the Client and Freeman relative to any loss, damage, or claim, Client shall not be entitled to and shall not withhold payment, or any partial payment, due to Freeman for its services, as an offset against the amount of any alleged loss or damage. Any claim against Freeman shall be considered a separate transaction, and shall be resolved on its own merits.

TERMS AND CONDITIONS: All goods scheduled in this Agreement are received and accepted by Freeman on Client's express representation that it is lawfully authorized to store the goods. FREEMAN WILL NOT ACCEPT FOR STORAGE, NOR BE LIABLE FOR, ANY OF THE FOLLOWING: DOCUMENTS, CURRENCY, MONEY, JEWELRY, WATCHES, PRECIOUS STONES, ART WORK, ANTIQUES, FURS, OR OTHER ARTICLES OF EXTRAORDINARY VALUE; NOR WILL WE ACCEPT ANY PERISHABLE ITEMS, LIQUID, ILLEGAL SUBSTANCES, OR ANY HAZARDOUS MATERIALS OR WASTE AS DEFINED BY 49 CFR 173. Client agrees to defend and indemnify Freeman from and against any and all claims, demands, judgments, and costs (including reasonable attorneys' fees) arising out of or relating to the ownership or title to goods stored, or arising from the storage of any of the above prohibited items in violation of this Agreement. Freeman is expressly given an additional lien on the goods stored by Client for all such costs, expenses, and attorney fees. Freeman shall have a lien on any and all property deposited with it at any time. All goods deposited on which storage or other charges including handling charges are not paid when due may be sold at public or private sale to pay such accrued charges, together with expenses of the sale, after notice to Client or other interested persons of the manner, time, and place of the sale and the amount of the accrued charges as may be required by law. Freeman shall only be liable for any loss or injury to the goods caused by its failure to exercise such care as a reasonable, careful owner of similar goods would exercise, subject to the limitation on damages. Freeman does not represent or warrant that its buildings or the contents of such buildings cannot be destroyed by fire. Freeman shall not be required to maintain a sprinkler or alarm system, security guard or other preventative / security devices, and its failure to do so shall not constitute negligence. FREEMAN IS NOT RESPONSIBLE TO CLIENT, ITS PRINCIPAL OR INSURER FOR, AND CLIENT RELEASES FREEMAN FROM, ANY LOSS OR DAMAGE TO GOODS CAUSED BY FIRE, INSECTS, RODENTS, RUST, NORMAL WEAR AND TEAR, LEAKAGE, MOISTURE, CHANGES IN TEMPERATURE, STRIKES, ACT OF GOD, DETERIORATION BY TIME, OR MARRING AND/OR SCRATCHING (INCLUDING WITHOUT LIMITATION ANY SUCH DAMAGE CAUSED BY FREEMAN'S NEGLIGENCE); FOR ANY LOSS OR DAMAGE TO FRAGILE ARTICLES (INCLUDING WITHOUT LIMITATION ANY SUCH DAMAGE CAUSED BY FREEMAN'S NEGLIGENCE); FOR ANY LOSS OR DAMAGE TO THE CONTENTS OF ANY CONTAINER (INCLUDING WITHOUT LIMITATION ANY SUCH DAMAGE CAUSED BY FREEMAN'S NEGLIGENCE) UNLESS ITS CONTENTS ARE MADE KNOWN TO FREEMAN AND SPECIFICALLY ITEMIZED IN A RIDER ATTACHED TO THIS AGREEMENT; OR FOR ANY LOSS OR DAMAGE FROM CAUSES BEYOND FREEMAN'S CONTROL. FREEMAN SHALL NOT BE RESPONSIBLE FOR THE MECHANICAL FUNCTIONS OF INSTRUMENTS, APPLIANCES OR MACHINERY. FREEMAN'S FAILURE TO DELIVER GOODS TO ANY PERSON ENTITLED TO THEM SHALL NOT CONSTITUTE CONVERSION OF GOODS OR SUBJECT FREEMAN TO ANY LIABILITY WHATSOEVER WHEN THE NON-DELIVERY RESULTS FROM CAUSES ARISING FROM STRIKES, LOCKOUTS, WORK STOPPAGES OR RESTRAINTS OF LABOR. It is the responsibility of the client to obtain the appropriate insurance coverage. Goods are not insured by Freeman nor do storage rates include insurance. All terms of this Agreement, including without limitation, monthly rental, conditions of occupancy and charges are subject to change upon thirty (30) days prior written notice. If changed, the Client may terminate this agreement on the effective date of the change by giving Freeman ten (10) days prior written notice to terminate. If the client does not give such notice, the change shall become effective and apply to the Client's occupancy. Either party reserves the right to terminate the storage of the goods at any time by giving to the other party thirty (30) days written notice of its intention to do so. Unless Client removes such goods within that period, Freeman shall have the right to deliver such goods to Client at the address on file at Client's expense. It shall be the duty of the Client to furnish to Freeman notification, in writing, to Client's address provided herein of any change of address or phone number. This Agreement and any action arising between the parties shall be construed under and in accordance with the laws of Nevada.

ACCEPTANCE: I have read, understood and agree to be bound by the Terms and Conditions on both sides of this document, and further, that I have the authority to sign this on behalf of the owner of the goods/materials being stored.

SIGNATURE OF DEPOSITOR: _____

SIGNATURE OF FREEMAN REPRESENTATIVE: _____

storage agreement



Place your order online at www.freeman.com/store

(888) 508-5054

Submit order forms [here](#)

Fax: (469) 621-5604

NAME OF SHOW: **JCK Las Vegas 2022 / June 10-13, 2022**

COMPANY NAME: _____ BOOTH #: _____

CONTACT NAME : _____ PHONE #: _____

E-MAIL ADDRESS : _____

Take advantage of the Online Price by ordering at www.freeman.com/store by **MAY 09, 2022**.



EVERY OUTBOUND SHIPMENT WILL REQUIRE A MATERIAL HANDLING AGREEMENT AND SHIPPING LABELS. WE WOULD BE HAPPY TO PREPARE THESE FOR YOU AND DELIVER THEM TO YOUR BOOTH PRIOR TO SHOW CLOSE. TO TAKE ADVANTAGE OF THIS SERVICE, PLEASE COMPLETE AND RETURN THIS FORM TO THE FREEMAN SERVICE CENTER.

SHIPPING INFORMATION

SHIP TO: COMPANY NAME: _____

DELIVERY ADDRESS: _____

CITY: _____ STATE/ PROVINCE: _____ ZIP/ POSTAL CODE: _____

PHONE#: _____ ATTN: _____

SPECIAL INSTRUCTIONS: _____

BILL TO: Same as Ship to:

COMPANY NAME: _____

DELIVERY ADDRESS: _____

CITY: _____ STATE/ PROVINCE: _____ ZIP/ POSTAL CODE: _____

METHOD OF SHIPMENT

Select a Carrier:

- Freeman Exhibit Transportation** **Other Carrier**

No need to schedule your outbound shipment.
Charges will appear on your Freeman invoice.

Carrier Name: _____

Carrier Phone: _____

Freeman will make arrangements for all Freeman Exhibit Transportation shipments.
Arrangements for pick-up by other carriers is the responsibility of the exhibitor.

Select a Level of Service:

- 1 Day: Delivery next business day
- 2 Day: Delivery by 5:00 PM second business day
- Deferred: Delivery within 3-5 business days
- Standard Ground
- Specialized: Pad wrapped, uncrated, or truckload

Select Shipment Options (if applicable)

- Have loading dock
- Inside delivery
- Pad wrap required
- Do not stack
- Lift gate required
- Air ride required
- Residential

Select Desired Number of Labels: _____

Once your shipment is packed and ready to be picked up from your booth, please return completed the Material Handling Agreement to the Freeman Service Center. If no outbound information is submitted, Freeman reserves the right to return the freight back to the company address on file at the exhibitor's expense.

outbound shipping

SHIPPING LABELS INFORMATION

Included in the Exhibitor Service Manual and on FreemanOnline are pre-printed shipping labels for JCK Las Vegas 2022. These labels may be photocopied. Please ensure that you have placed at least one label on each piece that you will be sending.

Two different labels have been included for your convenience. Please ensure that you use the appropriate label.

SHOW SITE DIRECT

Use this label only for shipments arriving at the Venetian Expo & Convention Center between June 4, 2022 and June 9, 2022 in accordance with the dates and times designated for your booth on the Targeted Move-In Floor Plan. Check with your trucking company to see what their policy is about waiting times and weekend deliveries.

ADVANCE WAREHOUSE

Use this label if you prefer the convenience of not having to worry about your shipment arriving at a specific time. Your shipment can arrive at the warehouse as early as **Monday, May 2, 2022**, and be delivered to your booth in accordance with the Targeted Move-In Floor Plan. The deadline for delivery to the warehouse is **Thursday, May 26, 2022**.

Please pay particular attention to the deadline dates. Sending your shipments to meet these deadlines will save you money.

Note that if you would like to inquire about getting a different Freight Target Time, please complete the Target Move-In Change Request form. Should you have any questions regarding a change to your target date, please contact Ron Pickens at Ron.Pickens@freeman.com.

If at any time you have questions, please don't hesitate to contact Exhibitor Support at (888) 508-5054.

Thank you!

Freeman¹

R U S H

DO NOT DELAY

RECEIVING DATE BEGINS: MAY 02, 2022

DEADLINE DATE IS: MAY 26, 2022

TO: _____

EXHIBITOR NAME

**C/O: Freeman
6675 W Sunset Rd
La Vegas, NV 89118**

WAREHOUSE

(508986)

EVENT: **JCK Las Vegas 2022**

BOOTH NO: _____ NO. _____ OF _____ PCS

Freeman¹

R U S H

DO NOT DELAY

RECEIVING DATE BEGINS: MAY 02, 2022

DEADLINE DATE IS: MAY 26, 2022

TO: _____

EXHIBITOR NAME

**C/O: Freeman
6675 W Sunset Rd
La Vegas, NV 89118**

WAREHOUSE

(508986)

EVENT: **JCK Las Vegas 2022**

BOOTH NO: _____ NO. _____ OF _____ PCS

THE ABOVE LABELS ARE PROVIDED FOR YOUR CONVENIENCE.
PLACE ONE ON EACH PIECE SHIPPED TO ENSURE PROPER DELIVERY.
IF MORE LABELS ARE NEEDED, COPIES ARE ACCEPTABLE.

Freeman

Freeman

R U S H

R U S H

DO NOT DELAY

DO NOT DELAY

CANNOT DELIVER BEFORE JUNE 04, 2022

CANNOT DELIVER BEFORE JUNE 04, 2022

TO: _____
EXHIBITOR NAME

TO: _____
EXHIBITOR NAME

C/O: Freeman
Venetian Expo & Convention Center
201 Sands Ave
Las Vegas, NV 89169

C/O: Freeman
Venetian Expo & Convention Center
201 Sands Ave
Las Vegas, NV 89169

SHOW SITE

(508986)

EVENT: **JCK Las Vegas 2022**

SHOW SITE

(508986)

EVENT: **JCK Las Vegas 2022**

BOOTH NO: _____ NO. _____ OF _____ PCS

BOOTH NO: _____ NO. _____ OF _____ PCS

THE ABOVE LABELS ARE PROVIDED FOR YOUR CONVENIENCE.
PLACE ONE ON EACH PIECE SHIPPED TO ENSURE PROPER DELIVERY.
IF MORE LABELS ARE NEEDED, COPIES ARE ACCEPTABLE.

Standard Furniture Package

2022



The location of your booth is in a neighborhood that requires a booth display that meets the new visual branding guidelines set forth for the show (review full JCK Visual Branding Guidelines on other attachment in this mailing). You can make the selection of either bringing a custom booth that you own (which must be approved by JCK Show Management by April 1, 2022. Find out more on JCK Visual Branding Guidelines attachment) or you will need to utilize the standard exhibitor booth package for your designated neighborhood shown below.

Option A

One (1) Cafe Table (24" W x 30" H)
Two (2) Black Diamond Side Chairs



DISCOUNT PRICE: \$277.60
Regular Price: \$388.70

Option B

One (1) 4' White Draped Table
Two (2) Black Diamond Side Chairs

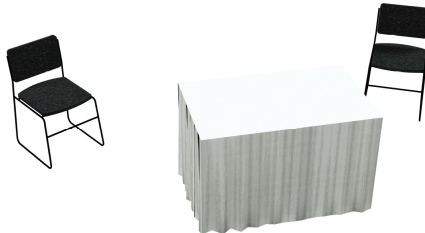

DISCOUNT PRICE: \$239.30
Regular Price: \$339.05

Option C

One (1) Cafe Table (36" W x 30" H)
Four (4) Black Diamond Side Chairs

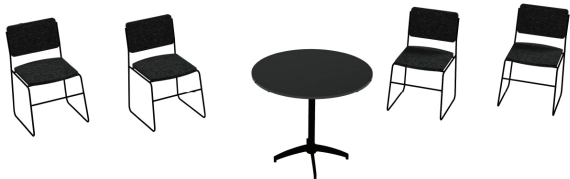

DISCOUNT PRICE: \$442.10
Regular Price: \$618.95

Option D

Two (2) White Draped Tables
Four (4) Black Diamond Side Chairs



DISCOUNT PRICE: \$478.55
Regular Price: \$678.10

Discount Deadline
May 9,
2022

ORDER FORM, HEADER FORM, AND ADVANCED PAYMENT MUST BE RECEIVED BY DEADLINE DATE.

*There will be a 8.38% tax on top of listed prices.

For Referral to a Sales Representative, please email:
JCKexhibits@freeman.com



(888) 508-5054
 Fax: (469) 621-5604



Place your order online at
www.freeman.com/store

Submit order forms [here](#).

NAME OF SHOW: **JCK Las Vegas 2022 / June 10-13, 2022**

COMPANY NAME: _____ BOOTH #: _____

CONTACT NAME: _____ PHONE #: _____

E-MAIL ADDRESS: _____

Take advantage of the Online Price by ordering at www.freeman.com/store by MAY 9, 2022.

FURNITURE PACKAGES

Part #	Description	Qty	Discount Price	Regular Price	Total
112510	Option A One (1) Cafe Table 24"W x 30"H Two (2) Black Diamond Side Chairs		\$227.60	\$388.70	\$
112511	Option B One (1) 4'L x 30"H White Draped Table Two (2) Black Diamond Side Chairs		\$239.30	\$339.05	\$
112512	Option C One (1) Cafe Table 36"W x 30"H Four (4) Black Diamond Side Chairs		\$442.10	\$618.95	\$
112513	Option D Two (2) 4'L x 30"H White Draped Tables Four (4) Black Diamond Side Chairs		\$478.55	\$678.10	\$

furniture packages

TOTAL COST

Total Cost = \$ _____

Applicable taxes will be applied to your order and invoiced accordingly based on specific venue jurisdiction but may also be based on the jurisdiction of where services are performed or your headquarters.

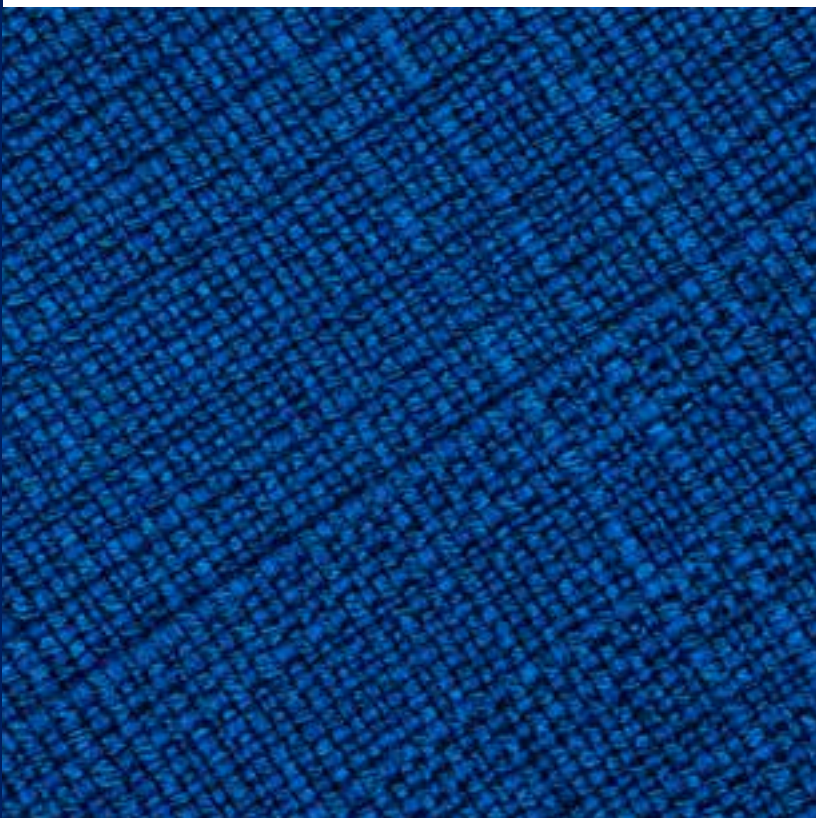

Exhibitor support

Visit us at freeman.com or call 1.888.508.5054 to speak to our award winning exhibitor support team.

Freeman® Trade Show Furnishings are proud to offer this collection of the highest quality, design-oriented furnishings. Our nationwide distribution and professional staff is dedicated to the success of your exhibit. Make Freeman® Trade Show Furnishings your furniture solution.

Furnishings Brochure



Comfortable and Safe Networking

Meaningful engagement doesn't have to be complicated.

Networking and connecting with peers face-to-face is a key objective of attending in-person events. Delivering environments which facilitate both ad-hoc and in-depth networking is important in accommodating attendee needs and will allow attendees to connect with peers effectively, comfortably, and safely.

To help you feel confident as you begin to plan your in-person and hybrid events, we have developed Freeman SafeConnect. This program includes standards, protocols, and service offerings that reflect our values and commitment to safety and wellbeing — for our people, our customers, and our attendees.

Learn more about Freeman SafeConnect at [Freeman.com](https://freeman.com)



Bowery Swivel Chairs & Sedona C-Tables

Accent Chairs | pg 16
Side Tables | pg 28
Dividers | pg 57
Greenery | pg 48

Top Design Tips

for Tradeshow Booths.

10. Provide a Pop!
Colorful furnishings attract attention and help reinforce brand themes.

9. Charge it!
Powered tables and seating encourages clients to linger in the booth and recharge.

8. Gather Round!
Ottomans styled around a side table create an informal campfire setting for small group discussions.

7. Stay Social.
Stylize furnishings to create shareable moments worthy of Instagram.

6. Level the field!
Low and casual seating makes clients more comfortable and open to learning.

5. Demo Down.
Square or circular ottomans are a great way to design small theaters for quick demonstrations.

4. Keep it Green.
Don't forget the greenery to warm up your booth environment by bringing nature indoors.

3. Creature Comforts.
Design a comfortable "living room" space with soft lounge seating to relax clients and encourage conversation.

2. Get Connected.
Communal tables help facilitate networking opportunities and build connections.

1. Spin Around.
Swivel chairs in small spaces maximize functionality and allow you to engage with those all around!

Complete The Look Of Your Exhibit Space

Freeman makes it easy to furnish your next exhibit space with recommended booth packages available on FreemanOnline. To view all available booth packages for your event and order your favorite, visit freeman.com/store.



The Showcase 10'x10' booth package is designed for exhibitors with small, high value items to display. Multiple cabinets elevate your products and make it easy to catch the eye of attendees.
Shown here with Zoey Barstools

The Cinematic 10'x20' booth package is designed for exhibitors needing large monitors to display presentations, while hosting attendees in a comfortable and inviting environment.
Shown here with Banana Barstools



The Gather 10'x10' booth package turns your booth into a comfortable oasis from the bustle of the show floor. Ideal for comfortable one-on-one time with prospects.
Shown here with Baja Chairs and Sydney Power Cocktail Table

Power Up In Style.

Denotes Powered Products 

Powered Seating

Empower attendees at your next show with functional charging furniture and make searching for wall outlets history. From soft seating and tables to pedestals and lamps, our complete charging collection lets you Power Up the Possibilities.



HEDGE
85035
4' Boxwood Hedge
46"L 9"D 47"H



NAPLES 
830121
Naples Sofa, Powered
(black vinyl)
87"L 30"D 33.25"H

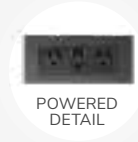

NAPLES 
810120
Naples Chair, Powered
(black vinyl)
36"L 30"D 33.25"H



NAPLES 
830122
Naples Loveseat, Powered
(black vinyl)
62"L 30"D 33.25"H





Powered Tables

Use
Ventura 6'
Bar or Café Tables
in your design to
facilitate conversations
while social
distancing.

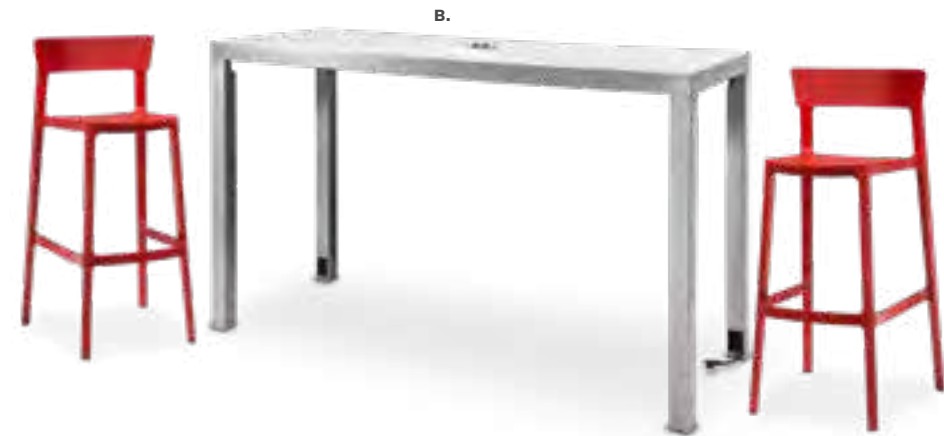
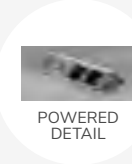

**Ventura Powered
Bar Tables**
72.25"L 26.25"D 42"H
(silver frame)
A) 820950 (black top)
B) 820955 (white top)



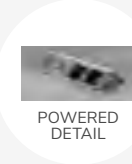

**Ventura Powered
Café Tables**
72.25"L 26.25"D 30"H
(silver frame)
C) 820964 (black top)
D) 820965 (white top)



Please Note: Customer is responsible for providing labor and an electrical power source to the furniture. One 110V power source is required for each charging panel. Two charging units can be daisy chained together. 10A max per charging panel.

Take Charge.

Denotes Powered Products 

Powered Tables

Empower attendees at your next show with functional charging furniture and make searching for wall outlets history. From soft seating and tables to pedestals and lamps, our complete charging collection lets you Power Up the Possibilities.

SYDNEY 
Sydney Powered Cocktail Tables
 48"L 26"D 18"H (brushed steel)
E) 82073 (white)
F) 82076 (black)

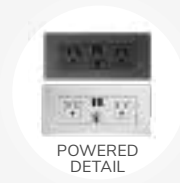

Please Note: Customer is responsible for providing labor and an electrical power source to the furniture. One 110V power source is required for each charging panel. Two charging units can be daisy chained together. 10A max per charging panel.

Powered Pedestals

Denotes AC and USB charging outlets 

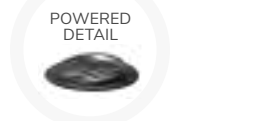
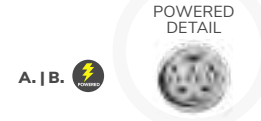

Powered Locking Pedestal
 (white)
A) 85061 24"L 24"D 36"H
B) 85063 24"L 24"D 42"H (black)
C) 85060 24"L 24"D 36"H
D) 85062 24"L 24"D 42"H

(The flip top electrical units rotate 180 degrees, allowing devices to be charged from inside the locked cabinet or on the surface.)

Powered Tech Desk



A) 84083 Tech Desk, Powered w/ 3 Drawer File Cabinet
 (black metal, laminate)
 60"L 30"D 30"H

B) 84084 Tech Desk, Powered
 (black metal, laminate)
 60"L 30"D 30"H

C) 84080 3 Drawer File Cabinet on Castors
 (black metal, laminate)
 16"L 20"D 28"H

Take Charge.

Denotes Powered Products 

Powered Tech Tablet Chair

Create an engaged learning environment at your next exhibit with the exclusive, powered Tech Tablet Chair. The soft dove gray vinyl chair features a removable white swivel tablet, an under-seat shelf for personal storage and an in-arm charging panel with three USB ports. An additional AC outlet is located at the base of the chair.

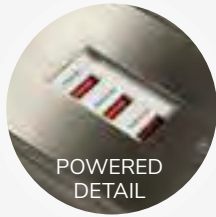

- A) **81039 Tech Tablet Chair**
(gray vinyl, white metal tablet, chrome base)
30.5"L 29"D 33.5"H
- B) **81038 Tech Chair, No Tablet**



Please Note: Customer is responsible for providing labor and an electrical power source to the furniture. One 110V power source is required for each charging panel. Two charging units can be daisy chained together. 10A max per charging panel.

Powered Products

Denotes AC and USB charging outlets 

Wireless Charging Table



-  **820710 Wireless Charging Table, Powered**
(white, AC plug-in)
20"L 20"D 18"H
Mobile devices must have Qi wireless charging capability.



Village Charging Hub

-  **8502 Village Charging Hub**
(cream)
12"L 12"D 28.25"H



Please Note: Customer is responsible for providing labor and an electrical power source to the furniture. One 110V power source is required for each charging panel. Two charging units can be daisy chained together. 10A max per charging panel.

Soft Seating

Create Engaging Booth Environments

VALENCIA

810180 Chair
(spice orange velvet)
28"L 30.5"D 31"H
83045 Sofa
(coffee brown velvet)
63"L 30.5"D 31"H

MARCHE
81540 Swivel Ottoman
(Forest Green Vinyl)
17"RND 18"H



Valencia Sofa & Chair 10'x10' Booth

HEDGE

85035
4' Boxwood Hedge
46"L 9"D 47"H

Soft Seating Collections



BAJA

A) 83019 Sofa
(white vinyl)
86"L 28"D 30"H

B) 81050 Chair
(white vinyl)
36"L 30.5"D 28"H

C) 83020 Loveseat
(white vinyl)
61"L 30.5"D 28"H



STERLING

A) 8309 Sofa
(gray fabric)
82"L 33.5"D 32"H

B) 81037 Chair
(gray fabric)
33"L 33.5"D 32"H



VALENCIA

A) 810180 Chair
(spice orange velvet)
28"L 30.5"D 31"H

B) 83045 Sofa
(coffee brown velvet)
63"L 30.5"D 31"H



KEY LARGO

A) 830951 Sofa
(black fabric)
79"L 35"D 34"H

B) 810950 Chair
(black fabric)
35"L 35"D 34"H

C) 830950 Loveseat
(black fabric)
57"L 35"D 34"H

Soft Seating

Denotes Powered Products 

Create Engaging Booth Environments

HEDGE
85035
4' Boxwood Hedge
46"L 9"D 47"H

PALM BEACH
83040 Sofa
(white vinyl, brushed metal)
69"L 29"D 33"H

SWANSON
810875 Swivel Chair
(white vinyl)
28"L 25"D 30"H



Palm Beach Sofa & Swanson Chairs 10'x10' Booth



PALM BEACH
83040 Sofa
(white vinyl, brushed metal)
69"L 29"D 33"H

Soft Seating Collections

Available in Power 



A.



B.

ALLEGRO
A) 81019 Chair
(blue fabric)
36"L 34.5"D 30"H
B) 83015 Sofa
(blue fabric)
73"L 34.5"D 30"H



A.



B.

FAIRFAX
A) 830949 Sofa
(white vinyl, brushed metal)
62"L 26"D 30"H
B) 810949 Chair
(white vinyl, brushed metal)
27"L 26"D 30"H



B.



A.

NAPLES 
A) 810119 Chair
(black vinyl)
36"L 30"D 33.25"H
810120 (Powered)

B) 830119 Sofa
(black vinyl)
87"L 30"D 33.25"H
830121 (Powered)



C.

C) 830120 Loveseat
(black vinyl)
62"L 30"D 33.25"H
830122 (Powered)

Accent Chairs

Create Space

Swivel chairs maximize functionality and allow you to engage safely with those all around. They're particularly helpful in smaller spaces!



81034
Bowery Swivel Chair
(ochre fabric, chrome)
29.75"L 31"D 27.25"H



810875
Swanson Swivel Chair
(white vinyl)
28"L 25"D 30"H



810874
La Brea Chair
(charcoal gray, fabric)
35"L 27"D 40"H



810145
Wentworth Chair
(brown vinyl)
32.1"L 26"D 31.5"H

Meeting & Stage Chairs



Marina Chair
17.5"L 19.5"D 35"H
A) 810164 (white vinyl)
B) 810160 (black vinyl)
C) 810161 (brown fabric)



810948
Meeting Chair
25.5"L 23.5"D 34"H
(white vinyl)

Accent Chairs

Accent Chair Styles



Madrid
810816 Chair
(white, chrome)
30"L 30"D 31"H



Montreal
81031 Chair
(blue, black metal)
30"L 23.25"D 30"H



Accent Tables | pg 26



Lena
81036 Chair
(moss green leather, bronze)
27"L 25"D 31"H



810949
Fairfax Chair
(white vinyl, brushed metal)
27"L 26"D 30"H



A) 810151
Munich Armless Chair
(gray fabric)
22.5"L 27"D 28.5"H

B) 81035
Century Chair
(gray velvet)
30"L 30"D 31"H

C) 81024
Atherton Chair
(distressed brown leather,
blackened steel)
27"L 31"D 30"H

D) 810947
Pro Executive
Guest Chair
(black vinyl)
24"L 26"D 36"H

E) 81032
Pasadena Chair
(white molded plastic
w/ chrome tower base)
27"L 25"D 26"H

F) 81037
Sterling Chair
(gray fabric)
33"L 33.5"D 32"H



A.



B.



D.



E.



F.

Group Seating

Lounges

Carefully designed lounges deliver a safe and effective setting for casual and relaxed connections. The strategic placement of other furniture pieces—like coffee tables, room dividers, and large plants—helps to maintain order and preserve social distancing protocols while delivering comfortable and safe networking.

ZENITH

A) 810851 Chair
(white, chrome)
18.25"L 22"D 32"H

**B) 820241
Madison Hydraulic
Café Table**
(chrome base, gray
acajou top)
30"RND 29"H



LAGUNA

C) 810861 Chair
(maple, chrome)
18"L 19"D 34"H

**D) 8201223
Round Café Table**
(white laminate top,
chrome hydraulic base)
30" RND 29"H



MALBA

20"L 20"D 32"H
A) 810131 Chair (gray)
B) 810130 Chair (green)



MARINA

17.5"L 19.5"D 35"H
A) 810164 (white vinyl)
B) 810160 (black vinyl)
C) 810161 (brown fabric)
D) 810162 (ocean blue fabric)
E) 810163 (red fabric)



Styles & Shapes

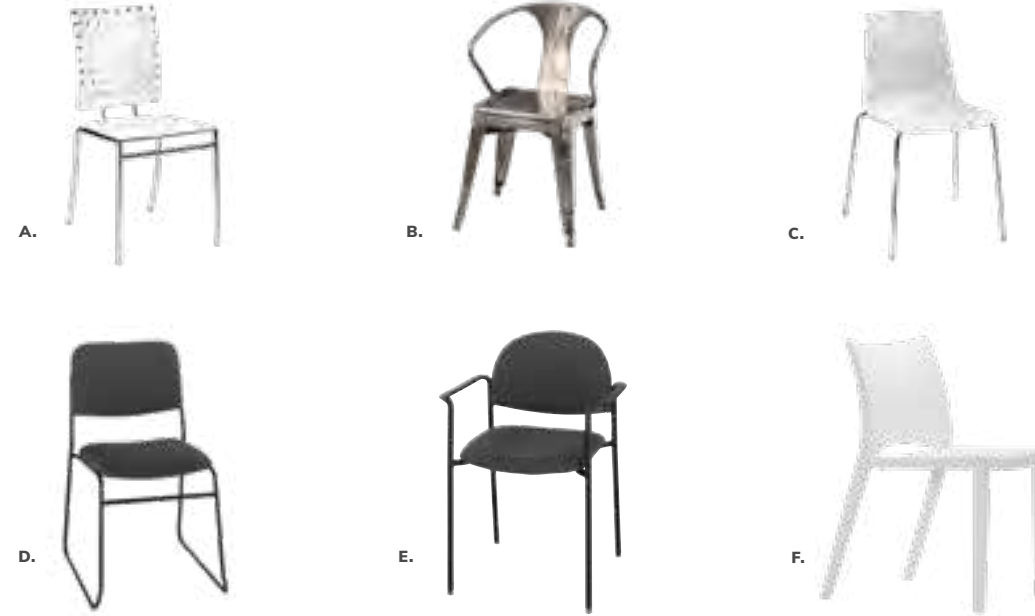

**A) 810846
Christopher Chair**
(white vinyl, chrome)
17"L 19"D 35"H

**B) 810841
Rustique Chair w/arms**
(gunmetal)
20"L 18"D 31"H

**C) 81093
Lucent Chair**
(frosted, acrylic)
19.5"L 19.75"D 32.5"H

**D) 71089
Diamond Side Chair**
(black)
21"W X 23"L X 32"H

**E) 71090
Diamond Arm Chair**
(black)
20"W X 21"L X 33"H

**F) 810837
Razor Armless Chair**
(white)
15.38"L 15.5"D 30.5"H

**G) 81083
Blade Chair**
(sky blue)
20.5"L 19"D 30.5"H

**H) 81082
Blade Chair**
(red)
20.5"L 19"D 30.5"H



Mix & Match

Create the ultimate seating configuration. Choose from a variety of shapes and sizes to design the perfect look.

I) 210108 LIMERICK® Chair BY HERMAN MILLER™
(gray) 18"W X 17.75"L X 33"H



Ottomans

Vibe Cube

18"L 18"D 18"H

- A) 81535 (citrus green vinyl)
- B) 81537 (spice orange vinyl)
- C) 81538 (desert rose vinyl)
- D) 81536 (taupe vinyl)
- E) 81531 (white vinyl)
- F) 81530 (black vinyl)
- G) 81532 (steel blue vinyl)
- H) 81534 (purple vinyl)
- I) 81533 (silver vinyl)
- J) 81519 (red vinyl)
- K) 81517 (yellow vinyl)
- L) 81518 (blue vinyl)
- M) 81525 (orange vinyl)

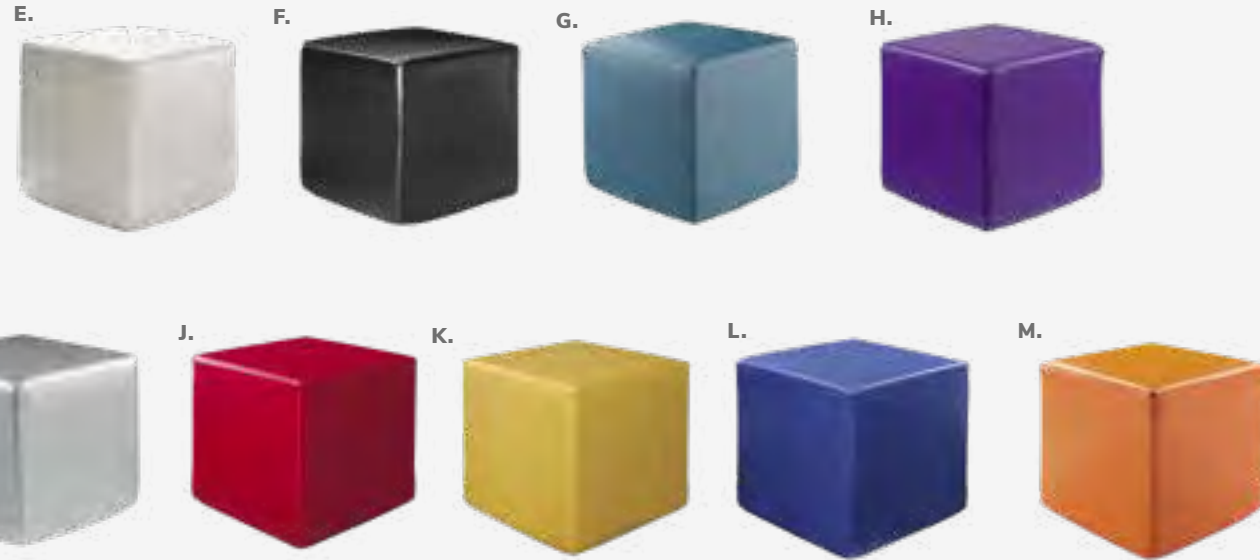

Beverly Bench Ottomans



- Beverly Bench**
60"L 20"D 18"H
- A) 81556 (white vinyl)
 - B) 81550 (black vinyl)
 - C) 81552 (gray fabric)
 - D) 81555 (red fabric)
 - E) 81554 (ocean blue fabric)
 - F) 81553 (linen fabric)
 - G) 81551 (brown fabric)

Styles & Shapes



- ENDLESS Square**
34"L 34"D 15"H
- A) 815123 (black)
 - B) 815122 (white)
- ENDLESS Curved**
60.5"L 37.5"D 15"H
- C) 815952 (black)
 - D) 815953 (white)



- E) 82074
Regis Bench
(brushed metal)
47"L 15.5"D 16"H

Ottomans

Beverly Small Bench Ottomans

30"L 20"D 18"H

- A) 81567 (orange fabric)
- B) 81563 (olive green fabric)
- C) 81569 (white vinyl)
- D) 81560 (black vinyl)
- E) 81561 (ocean blue fabric)
- F) 81562 (brown fabric)
- G) 81564 (gray fabric)
- H) 81565 (linen fabric)
- I) 81566 (lavender fabric)
- J) 81568 (red fabric)
- K) 81570 (yellow fabric)



Marche Swivel Ottomans



Marche Swivel Ottomans

17" RND 18"H

- A) 815150 (white vinyl)
- B) 815154 (red fabric)
- C) 81539 (Ivory Faux Sheep Fur)
- D) 815158 (pear yellow fabric)
- E) 815156 (plum fabric)
- F) 815159 (blue fabric)
- G) 815151 (gray fabric)
- H) 815155 (rose quartz fabric)
- I) 815152 (linen fabric)
- J) 815153 (raspberry fabric)
- K) 815157 (meadow green fabric)
- L) 815160 (orange fabric)
- M) 81543 (black vinyl)
- N) 81540 (forest green vinyl)
- O) 81541 (teal velvet)
- P) 81542 (distressed brown vinyl)

Accent Tables

Tables and Meeting Rooms

When you want to facilitate more in-depth conversations and provide work surfaces, be sure to use appropriately-sized tables. As always, create generous aiseways between meetings spaces; this will help individuals feel comfortable networking.



MESA

A) 820135 End Table
20.5"RND 21.25"H (wood top, bronze)
B) 820132 Cocktail Table
32.25"RND 17.25"H (wood top, bronze)

C) 820134 End Table
24"RND 21.25"H (glass top, bronze)
D) 820131 Cocktail Table
36"RND 17.25"H (glass top, bronze)

E) 820133 End Table
20.5"RND 21.25"H (black top, bronze)
F) 820130 Cocktail Table
32.25"RND 17.25"H (black top, bronze)

Styles & Shapes



ALONDRA

Cocktail Table
47"L 24"D 16"H
A) 820250 (glass, chrome)
B) 820251 (wood, chrome)

End Table
20"L 20"D 20"H
C) 820252 (glass, chrome)
D) 820253 (wood, chrome)

GEO

Cocktail Table
50"L 22"D 16"H
A) 82034 (glass, chrome)
B) 82027 (wood, black)

End Table
26"L 26"D 20"H
C) 82035 (glass, chrome)
D) 82028 (wood, black)

Accent Tables

Tables and Meeting Rooms

TAOS SIDE TABLES

15.75"L 15.75"D 24"H
A) 820322
 (white top, bronze)
B) 820320
 (black top, bronze)
C) 820321
 (wood top, bronze)



SEDONA SIDE TABLE

15.75"L 15.75"D 24"H
D) 820312
 (white top, bronze)
E) 820310
 (black top, bronze)
F) 820311
 (wood top, bronze)



Styles & Shapes

Available in Power



SYDNEY

Cocktail Tables
 (brushed steel)
 48"L 26"D 18"H
A) 82053 (white)
82073 (powered)
B) 82052 (black)
82076 (powered)
C) 82077 (blue)
D) 82078 (wood)

End Tables
 27"L 23"D 22"H
E) 82055 (white)
F) 82054 (black)
G) 82079 (blue)
H) 82080 (wood)

REGIS

(brushed metal)
I) 82074 Bench Table
 47"L 15.5"D 16"H
J) 82075 End Table
 16"L 15.5"D 16.5"H

SILVERADO

(glass, chrome)
K) 82015 End Table
 24" RND 22"H
L) 82014 Cocktail Table
 36" RND 17"H

WIRELESS

M) Charging Table, Powered
N) 820710
 (white, AC plug-in)
 20"L 20"D 18"H

AURA

Round Table
N) 820844
 (white metal)
 15" Round 22"H

Café Tables



A) 820940 Blue Hydraulic Café Table
(chrome base, blue top) 30" RND 29"H
B) 810131 Malba Chair
(gray) 20"L 20"D 32"H



A) 820241 Madison Hydraulic Café Table
(chrome base, gray acajou top) 30" RND 29"H
B) 810130 Malba Chair
(green) 20"L 20"D 32"H

85030 7' Boxwood Hedge
36.5"L 12"D 84"H



30" Round Café Table
A) 820941 Standard Black Base (blue top) 30" RND 29"H
B) 81093 Lucent Chair (frosted, acrylic) 19.5"L 19.75"D 32.5"H



A) 8201233 Hydraulic Cafe Table
(orange top, chrome) 30" RND 29"H
B) 810861 Laguna Chair
(maple, chrome) 18"L 19"D 34"H

Customize and Create

Choose your base, black or chrome, then pick a color that suits your design.

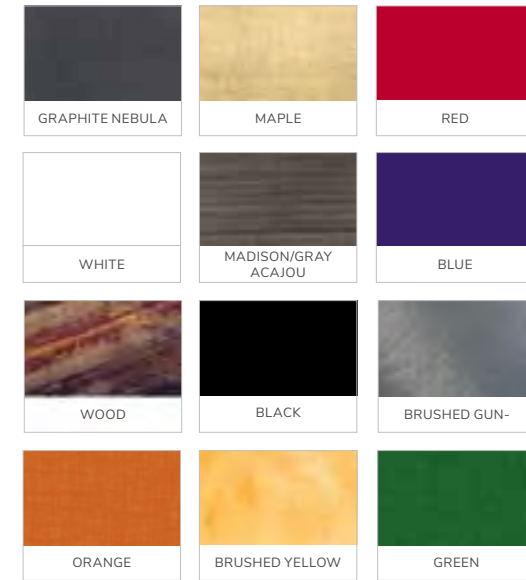

Café Tables Standard Black Base 30" RND 29"H

- A) 8201220** (white) also available
- 820265** (Madison/gray acajou)
- 820941** (blue)
- 820943** (wood)
- 8201236** (black)
- 8201235** (brushed gunmetal)
- 8201239** (brushed yellow)
- 8201237** (green)
- 8201238** (orange)

36" RND 29"H
8201243 (black)

Café Tables Hydraulic Chrome Base 30" RND 29"H

- B) 820923** (graphite nebula) also available
- 8201208** (maple)
- 820921** (red)
- 820940** (blue)
- 820942** (wood)
- 8201223** (white)
- 8201231** (black)
- 8201230** (brushed gunmetal)
- 8201234** (brushed yellow)
- 8201232** (green)
- 8201233** (orange)

36" RND 29"H
820126 (white)
8201209 (graphite nebula)
8201206 (maple)
8201242 (black)

Mix & Match

Create your look. Choose from a wide variety of tables and seating options.



C) 72063 Chelsea Butcher Block-Top Café Table
(oak) 30" RND 30"H
also available
72064 36" RND 30"H

D) 810164 Marina Chair
(white vinyl) 17.5"L 19.5"D 35"H

E) 72069 Soho Black-Top Café Table
(black) 24" RND 30"H
also available
72067 36" RND 30"H | **72066** 18" RND 18"H

F) 81082 Blade Chair
(red) 20.5"L 19"D 30.5"H



Bar Tables

A) 8201222 30" Round Bar Table
(white top, chrome hydraulic base) 30" RND 45"H
B) 81080 Blade Barstool (red) 20.5"L 20.125"D 40.5"H



C) 8201226 Rustique Square Metal Bar Table
(gunmetal) 23.75"L 23.75"D 41.25"H
D) 810839 Rustique Barstool
(gunmetal) 13"L 13"D 30"H



E) 820930 30" Round Bar Table
(blue top, chrome hydraulic base) 30" RND 45"H
F) 810860 Laguna Barstool (maple, chrome) 18"L 20"D 47"H



G) 820240 30" Round Bar Table w/ Hydraulic Chrome Base
(Madison/gray acajou) 30" RND 45"H
H) 810848 Christopher Barstool (white vinyl, chrome) 19"L 15"D 41"H



Customize and Create

Choose your base, black or chrome, then pick a color that suits your design.

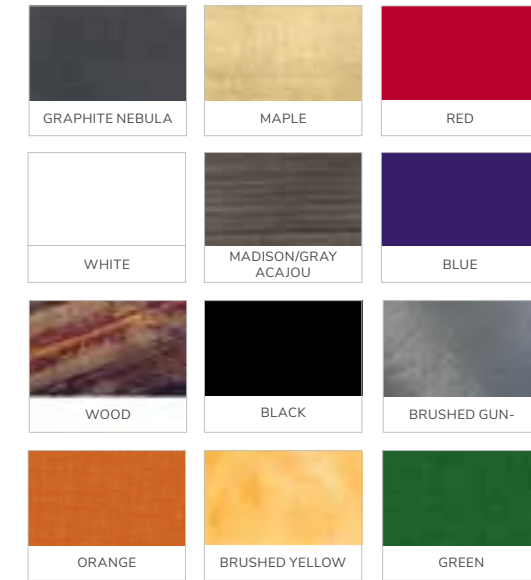

Bar Tables Standard Black Base 30" RND 42"H

A) 8201221 (white)
B) 820919 (brushed yellow)
also available
820264
(Madison/gray acajou)
820915 (brushed gunmetal)
820916 (black)
820917 (green)
820918 (orange)
820931 (blue)
820933 (wood)

36" RND 42"H
8201241 (black)

Bar Tables Hydraulic Chrome Base 30" RND 45"H

C) 820920 (red)
also available
8201207 (maple)
820922
(graphite nebula)
820910 (brushed gunmetal)
820911 (black)
820912 (green)
820913 (orange)
820914 (brushed yellow)
820930 (blue)
820932 (wood)
8201236 (black)

36" RND 45"H
820125 (white)
8201211 (graphite nebula)
8201205 (maple)
8201240 (black)

Style & Design

Choose from a variety of table top colors and styles for the perfect look.



C) 720163 Chelsea Butcher Block-Top Bistro Table
(oak) 30" RND 42"H
also available
720164 36" RND 42"H

D) 81092 Lucent Barstool
(frosted, acrylic) 22"L 22.5"D 45.5"H

E) 72070 Soho Black-Top Bistro Table
(black) 24" RND 42"H
also available
72068 36" RND 42"H

F) 810840 Zoey Barstools
(white, chrome)
15"L 16"D 30-34.75"H



Barstools

LIFT Barstools

- 15" RND 23-33.5"H
A) 810870 (white vinyl)
B) 810873 (red vinyl)
C) 810871 (black vinyl)
D) 810872 (gray vinyl)



Marina Barstools



Marina Barstools
21"L17.5"D41.5"H

- A) 81026 (ocean blue fabric)
B) 81028 (brown fabric)
C) 81029 (red fabric)
D) 81030 (white vinyl)
E) 81027 (black vinyl)

All frames brushed metal.

Barstools

Mix & Match

A) 810840
Zoey Barstools
 (white, chrome)
 15"L 16"D 30-34.75"H

Banana Barstools
 21"L 22"D 41.75"H
B) 810104 (black, chrome)
C) 810103 (white, chrome)

D) 810848
Christopher Barstool
 (white vinyl, chrome)
 19"L 15"D 41"H

E) 810202
Shark Barstool
 (white, chrome)
 22"L 19"D 34-44"H

F) 810850
Zenith Barstool
 (white, chrome)
 19"L 20"D 44"H

G) 81092
Lucent Barstool
 (frosted, acrylic)
 22"L 22.5"D 45.5"H



210109 LIMERICK®
Stool BY HERMAN MILLER™
 (white) 18" X 17.75"L X 44"H



720163
Butcher Block-Top Bistro
 (oak) 30"L RND 42"H
 also available
720164 36" RND 42"H

Barstools Styles & Shapes



H) 810860
Laguna Barstool
 (maple, chrome)
 18"L 20"D 47"H

Blade Barstool
 20.5"L 20.125"D 40.5"H
I) 81080 (red)
J) 81081 (sky blue)

K) 71088
Black Diamond Stool
 (black) 22"W X 18"L X 46"H

L) 810839
Rustique Barstool
 (gunmetal)
 13"L 13"D 30"H

Conference Tables

42" Round Conference Table

42"RND 29"H
A) 820708 (white laminate)
B) 820260 (Madison/gray acajou)
C) 8201244 (black top, black)



Atomic Round Tables
 (glass, chrome)
8201225 42" RND 30"H
8201224 36" RND 30"H

Pro Executive Mid Back Chair
 24"L 22"D 40"H
A) 810945 (white vinyl)
B) 810944 (black vinyl)
 Adjustable height



Geo Tables



Geo Rectangular Tables
 60"L 36"D 29"H
E) 82041 (glass, black)
F) 82051 (glass, chrome)

Geo Rounded Square Tables
 42"L 42"D 29"H
G) 82044 (glass, chrome)
H) 82043 (glass, black)

Work Space



I) 820706 Work Table
 (white laminate, white)
 48"L 24"D 30"H

Conference Tables

Madison

(Madison/gray acajou)
A) 820261 5' Table
 60"L 48"D 29"H

B) 820262 8' Table
 96"L 60"D 29"H

C) 820263 10' Table
 120"L 48"D 29"H

A.



B.



C.



810175 Genesis Chair
 (black fabric, black)
 27.5"L 27.5"D 40-43.5"H Adjustable.

Black Rectangular Conference Table

A.



B.



C.



810170 Cupertino Mid Back Chair
 (black vinyl, chrome)
 27"L 30.5"D 40-43"H Adjustable.

Black Rectangular Conference Table
 (black top, silver)

A) 8203 5' Table
 60"L 48"D 29"H
8204 Powered

B) 8205 8' Table
 96"L 48"D 29"H
8206 Powered

C) 8201 10' Table
 120"L 48"D 29"H
8202 Powered

Executive Seating

Pro Executive High Back Chair

25"L 24"D 48"H
A) 810844 (white vinyl)
B) 810946 (black vinyl)
 Adjustable height



Cupertino Mid Back Chair

A) 810170 (black vinyl, chrome) 27"L 30.5"D 40-43"H Adjustable.

Genesis Chair

B) 810175 (black fabric, black) 27.5"L 27.5"D 40-43.5"H Adjustable.

Pro Executive Mid Back Chair

24"L 22"D 40"H
A) 810945 (white vinyl)
B) 810944 (black vinyl)
 Adjustable height



Pro Executive Guest Chair

24"L 22"D 36"H
810947 (black vinyl)



Task Stool

810135
 (black fabric)
 27.5"L 27.5"D 32.75"-40.25"H
 Adjustable height



Communal and Powered Tables

Choose from a variety of powered, solid or grommet hole table tops.

Table Top Options



Colors not available in all table options. Please check options listed to the right.

Denotes AC and USB charging outlets

POWERED DETAIL

Bar Tables



Ventura Powered Bar Tables

(silver frame)
 72.25"L 26.25"D 42"H

A) 820950 (black top)
B) 820955 (white top)

Ventura Communal Bar Tables

(silver frame)
 72.25"L 26.25"D 42"H

Maple Top
B) 820954 (solid)
820951 (grommets)

White Top
C) 820953 (grommets)
820956 (solid)

Black Top
820952 (solid)

Café Tables



Ventura Powered Café Tables

(silver frame)
 72.25"L 26.25"D 30"H

A) 820964 (black top)
B) 820965 (white top)

Ventura Communal Café Tables

(silver frame)
 72.25"L 26.25"D 30"H

Maple Top
C) 820963 (solid)
820960 (grommets)

White Top
D) 820961 (grommets)
820966 (solid)

Black Top
E) 820962 (solid)

Please Note: Customer is responsible for providing labor and an electrical power source to the furniture. One 110V power source is required for each charging panel. Two charging units can be daisy chained together. 10A max per charging panel.

Office Essentials



A.
DESK BACK

B.



DESK FRONT

MADISON

A) 84075 Madison Executive Desk
(gray acajou) 60"L 30"D 29"H

B) 810844 Pro Executive High Back Chair
(white classic vinyl) 25"L 24"D 48"H Adjustable

Tech Powered Desk

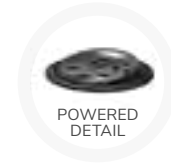

A. ⚡



C.

B. ⚡



Denotes AC and USB charging outlets

A) 84083 Tech Desk, Powered, w/ 3 Drawer File Cabinet
(black metal, laminate) 60"L 30"D 30"H

B) 84084 Tech Desk, Powered
(black metal, laminate) 60"L 30"D 30"H

C) 84080 3 Drawer File Cabinet on Castors
(black metal, laminate) 16"L 20"D 28"H

Please Note: Customer is responsible for providing labor and an electrical power source to the furniture. One 110V power source is required for each charging panel. Two charging units can be daisy chained together. 10A max per charging panel.

Lighting & Shelving

A.



B.



C.



D.



ACCENT LAMPS

Mason Lamps
(brushed silver)

A) 850708 Floor Lamp
18" RND 55"H

B) 850707 Table Lamp
16" RND 26"H

SHELVING

C) 85020

Posh Shelving
(chrome, acrylic)
36"L 18"D 72"H

D) 84078

Madison Bookcase
(gray acajou)
36"L 12"D 72"H

Show Essentials

Denotes AC and USB charging outlets 

Midtown Powered Counter

Metallic pewter gray curved counter with taupe-colored glass top features two AC outlets, three USB charging outlets, locking storage cabinet and two shelves.

 **Midtown Powered Counter**
60"L 18"D 42"H (pewter/glass)
850103 (unlighted)
850102 (lighted with plug-in)

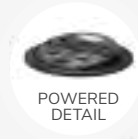
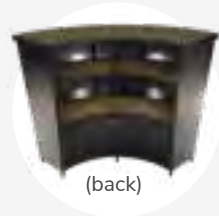

85030
7' Boxwood Hedge
36.5"L 12"D 84"H



810860
Laguna Barstool
(maple, chrome)
18"L 20"D 47"H

Midtown Bar

Metallic pewter gray curved bar with taupe-colored glass top features locking cabinet for storage and two shelves.

Midtown Bar
60"L 18"D 42"H (pewter)
A) 850101 (unlighted)
B) 850100 (lighted with plug-in)

C) 810840 Zoey Barstools
(white, chrome)
15"L 16"D 30-34.75"H

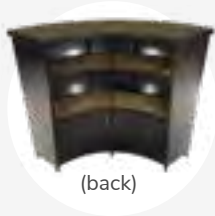

Please Note: Customer is responsible for providing labor and an electrical power source to the furniture. One 110V power source is required for each charging panel. Two charging units can be daisy chained together. 10A max per charging panel.

Product Display Counter



A) 72056
Display Counter
(black)
24"W X 49"L X 42"H

B) 210109
LIMERICK® Stool
BY HERMAN MILLER™
(white)
18" X 17.75"L X 44"H

Please Note: Customer is responsible for providing labor and an electrical power source to the furniture. One 110V power source is required for each charging panel. Two charging units can be daisy chained together. 10A max per charging panel.

Show Essentials

Greenery and Dividers

Metallic pewter gray curved counter with taupe-colored glass top features two AC outlets, three USB charging outlets, locking storage cabinet and two shelves.

HEDGE

- A) 85030
7' Boxwood Hedge
36.5"L 12"D 84"H
- B) 85035
4' Boxwood Hedge
46"L 9"D 47"H



Miramar Dividers



A.



Miramar Dividers
(molded plastic)
A) 85040 (white)
Vertical: 63"L 23"D 83"H
Horizontal: 83"L 23"D 63"H

B) 820930
30" Round Bar Table
(blue top, chrome hydraulic base)
30" RND 45"H
C) 810860 Laguna Barstool
(maple, chrome)
18"L 20"D 47"H

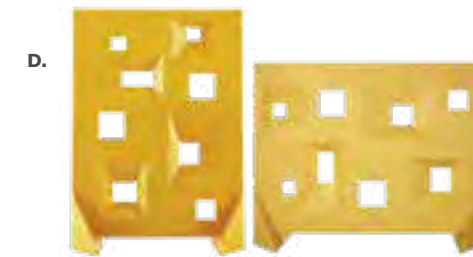

D.



E.

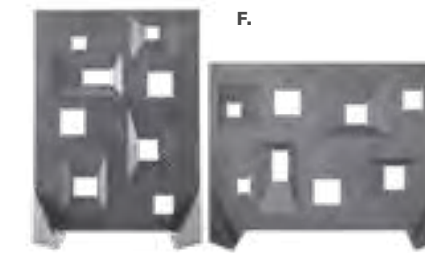

F.

Miramar Dividers
(molded plastic)
D) 85043 (harvest yellow)
E) 85042 (burgundy)
F) 85041 (gray)
Vertical: 63"L 23"D 83"H
Horizontal: 83"L 23"D 63"H

Show Essentials

Product Kiosk & Display

A) 75032
Display Cube—Large
 (black)
 24"W X 24"L X 42"H

B) 75031
Display Cube—Medium
 (black)
 18"W X 18"L X 36"H

C) 75030
Display Cube—Small
 (black)
 12"W X 12"L X 42"H



Draped or Undraped Tables & Counters

Table Drape Colors

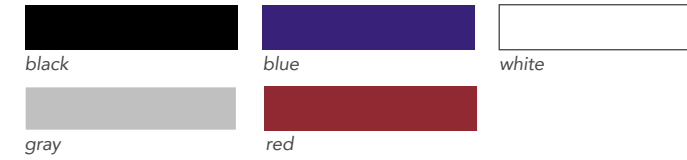

Visit us at freeman.com/store to view full product line and place order.



Stanchions & Signage

A) 220121
Chrome Stanchion
 w/ 8' Retractable Belt
 (black, belt) 42"H

B) 220118
Chrome Sign Holder
 (sign holds)
 22"W X 28"H



Sizing Chart*

24"D X 30"H | Tables Draped

124330 Tables Draped **3'L** x 24"D x 30"H
124430 Tables Draped **4'L** x 24"D x 30"H
124630 Tables Draped **6'L** x 24"D x 30"H
124830 Tables Draped **8'L** x 24"D x 30"H

24"D X 42"H | Counter Draped

124342 Counter Draped **3'L** x 24"D x 42"H
124442 Counter Draped **4'L** x 24"D x 42"H
124642 Counter Draped **6'L** x 24"D x 42"H
124842 Counter Draped **8'L** x 24"D x 42"H

24"D X 30"H | Tables Undraped

125330 Tables Undraped **3'L** x 24"D x 30"H
125430 Tables Undraped **4'L** x 24"D x 30"H
125630 Tables Undraped **6'L** x 24"D x 30"H
125830 Tables Undraped **8'L** x 24"D x 30"H

24"D X 42"H | Counter Undraped

125342 Counter Undraped **3'L** x 24"D x 42"H
125442 Counter Undraped **4'L** x 24"D x 42"H
125642 Counter Undraped **6'L** x 24"D x 42"H
125842 Counter Undraped **8'L** x 24"D x 42"H

4th Side | Table Draped 30"

12404630 Drape Table 4th Side **6' X 30"**
12404830 Drape Table 4th Side **8' X 30"**

4th Side | Table Draped 42"

12404642 Drape Table 4th Side **6' X 42"**
12404842 Drape Table 4th Side **8' X 42"**

Show Essentials

Storage



750135
Round Literature Rack
(black)
17"W X 17"L X 57"H



750136
Flat Literature Rack
(black)
10"W X 55"H

8503001
Large Refrigerator
(white) 14.0 cubic feet
28"W X 28"L X 64"H



84080
3 Drawer File Cabinet
on Castors
(black metal, laminate)
16"L 20"D 28"H



Office Accessories

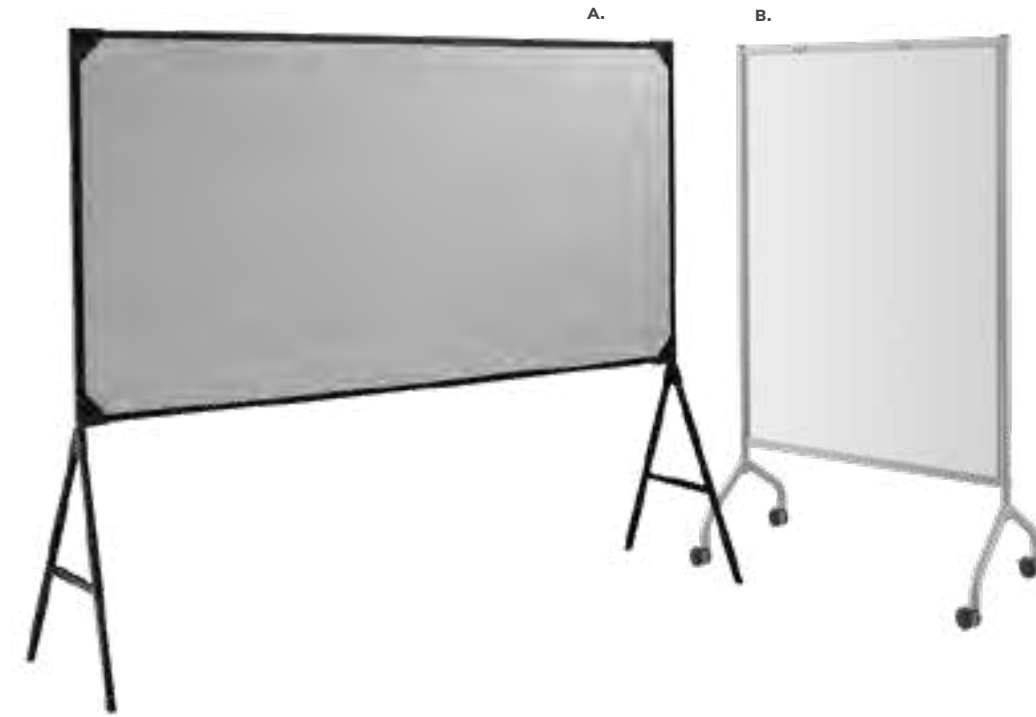

A) 10201484
Floor Standing Bulletin Board
(white laminate, black)
48"W X 96"L X 78"H

B) 84050
Mobile White Board
(white laminate, white)
48"L 24"D 30"H



C) 220110
Chrome Bag Rack
(3" at center)
1"W X 41"H X 26"W

D) 220109
Chrome Coat Tree
(21"w at the base)
8 1/4"W X 69 1/2"H

E) 220134
Brushed Aluminum Easel
(open 5 1/4"W X 64 1/4"H)
26"W X 62"H

F) 220106
Corrugated Wastebasket
(black)

Strategic planning with health & safety in mind

Health & Safety are the top priorities as we consider new designs and ways to connect. When those are clearly emphasized on the show floor, attendees will feel more confident re-engaging.

Together, let's imagine what this new experience will look like - based on both what is possible and realistic. Some recommendations may be new to you. Some, not. To get you started, our top five recommendations include

In all cases, we've put considerable thought into them.

[Click to learn more detailed, interactive, printable checklist.](#)

Freeman® top five health & safety Recommendations include:

1. Strategize your audience approach
2. Re-imagine your booth design.
3. Evaluate a hybrid booth approach
4. Create safe networking opportunities during the show
5. Stay connected to your audience post-show

[Learn More](#)

Health & Safety

Safety Dividers

Freeman, offers a complete collection of uniquely designed and safe selling environments that are clean, comfortable, and give your clients peace of mind.

Personalize here

85051 Freestanding Divider
(silver, clear) 39"L 9"D 72"H

Also available in opaque and personalization available.

- 85052 Divider Single Sided Graphic
- 85053 Divider Single-Sided Graphic
- 85090 Divider Double-Sided Graphic



85064 Flag Pole Divider
(silver, clear) 34"L 11"W 47-74"H

Also available in opaque and personalization available.



85055 Freestanding Wall Plus
(silver, clear) 40"L 9"D 72"H

Also available in opaque and personalization available.

- 85056 Panel Single-Sided Graphic
- 85057 Panel Single-Sided Graphic
- 85058 Panel Double-Sided Graphic

85054 Freestanding Corner
(silver, clear) 39"L 39"D 72"H

Also available in opaque and personalization available.



85091 Freestanding White Board
(silver, clear) 40"L 9"D 72"H

Also available in opaque and personalization available.



A) Atomic Round Tables
(glass, chrome)
8201225 42" RND 30"H
8201224 36" RND 30"H

B) 810944 Pro Executive Mid Back Chair
(black vinyl)
24"L 22"D 40"H
Adjustable height

Please Note:

Safety dividers also available in opaque finish. Graphics and branding options also available.

View those options [here](#) and learn more about our SafeConnect Promise on [Freeman.com](#)

Health & Safety

Greenery and Dividers

Keep it Green. Life-like greenery is an easy yet sophisticated way to bridge the distance between seats for a warmer, organic environment.

20'x20' Midtown, Greenery Booth

- Midtown Bar | pg 46
- Dividers | pg 59
- Accent Chair | pg 16
- Bar Tables | pg 7
- Barstools | pg 33
- Greenery | pg 48



85030
7' Boxwood Hedge
36.5"L 12"D 84"H

85035
4' Boxwood Hedge
46"L 9"D 47"H



85050 Clear Divider Bar Counter
(silver, clear) 48-70"L 12"W 31.5"H

Also available in opaque and personalization available.

- 85080** Divider with Header Graphic
- 85083** Divider with Front Panel Graphic
- 85081** Divider with Side Panel Graphic
- 85082** Divider with Header and Side Panel Graphic
- 85084** Divider with Front and Side Graphics



Personalize here

Please Note:

Safety dividers also available in opaque finish. Graphics and branding options also available.

View those options [Here](#) and learn more about our SafeConnect Promise on [Freeman.com](#)



A.

B.

C.

Miramar Dividers
(molded plastic)
A) 85043 (white)
Also available in the following colors.
See page 47.
85043 (harvest yellow)
85042 (burgundy)
85041 (gray)
Vertical: 63"L 23"D 83"H
Horizontal: 83"L 23"D 63"H

B) 8201233
Hydraulic Cafe Table
(orange top, chrome)
30" RND 29"H

C) 810861
Laguna Chair
(maple, chrome)
18"L 19"D 34"H

Health & Safety

Stanchions & Booth Design

Stanchions & Booth Design

Design unique and safe selling environments using stanchions. Create stylish spaces that are comfortable and give your clients peace of mind.



**10'x10' - Beverly
Demonstration Booth**

- Greenery | pg 48
- Safety Decals | pg 63
- Bar Tables | pg 33
- Barstools | pg 33
- Side Tables | pg 29
- Ottomans | pg 24



10'x10' - Atherton Conversation Booth

- Greenery | pg 48
- Accent Chairs | pg 16
- Side Tables | pg 29



**220121
Chrome Stanchion
w/ 8' Retractable Belt**
(black, belt) 42"H



**10'x20' - Wireless Charging
Engagement Booth**

- Bar Tables | pg 32
- Barstools | pg 33
- Charging Tables | pg 11
- Ottomans | pg 22

Health & Safety

Safety & Directional Signage

Please reach out to your Freeman contact to discuss suggested use and options. For additional questions please email healthandsafety@freeman.com Layout will include YOUR logo and basic background color.



220118
Chrome Sign Holder
(sign holds) 22"W X 28"H

10'x10' - Atherton Conversation Booth

Greenery | pg 48
Accent Chairs | pg 16
Side Tables | pg 29



Safety & Directional Signage

Design your next booth with Freeman safety signage. Choose from select signage or customize with your brand to complete any size space.

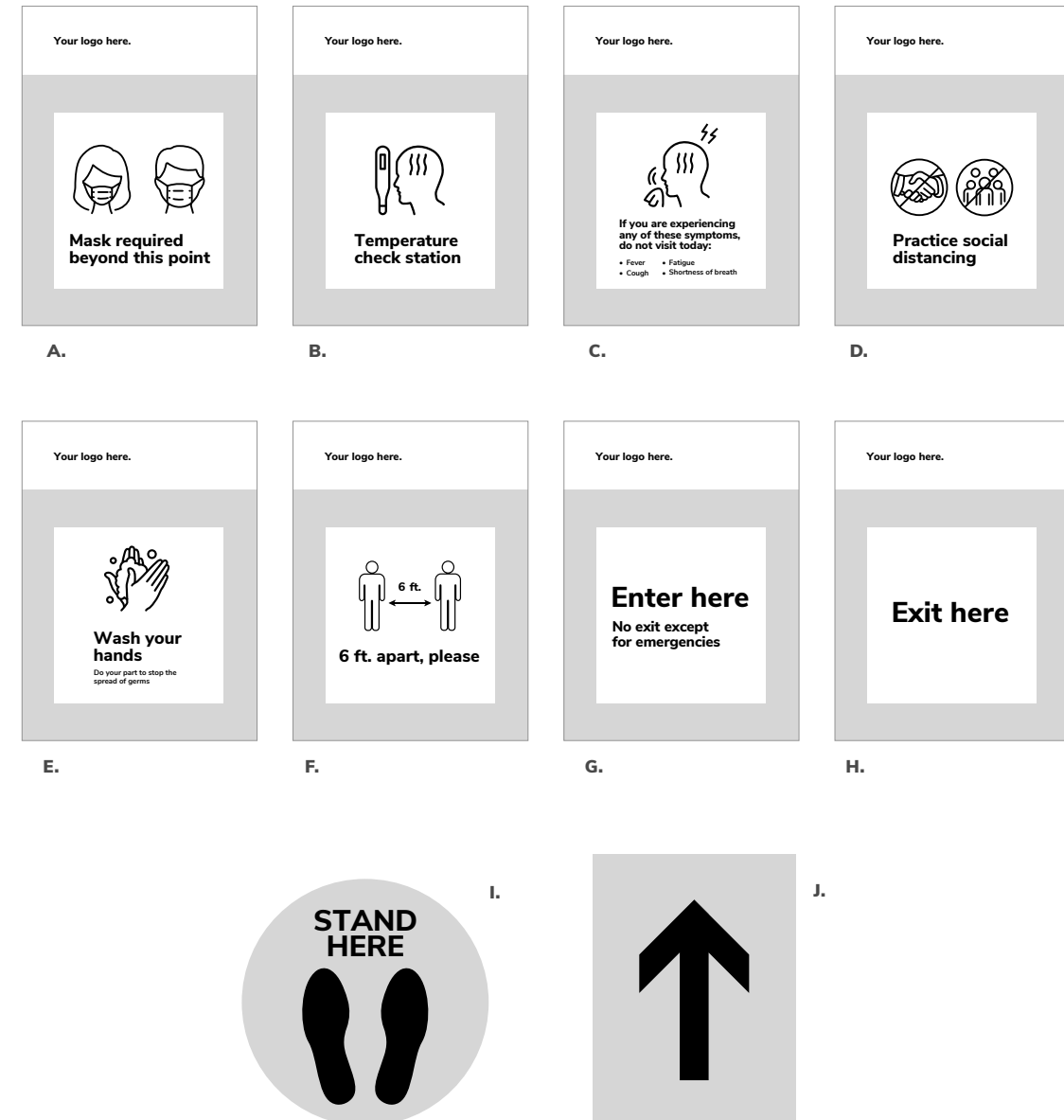

A) Masks Required Sign
20303001 22"W X 28"H
20303002 8.5" W X 11"H

B) Temperature Check Station Sign
20303003 22"W X 28"H
20303004 8.5"W X 11"H

C) If You Are Experiencing Symptoms Sign
20303005 22"W X 28"H
20303006 8.5"W X 11"H

D) Practice Social Distancing Sign
20303007 22"W X 28"H
20303008 8.5"W X 11"H

E) Wash Your Hands Sign
20303009 22"W X 28"H
20303010 8.5"W X 11"H

F) 6' Apart Please Sign
20303011 22"W X 28"H
20303012 8.5"W X 11"H

G) Enter Here Sign
20303013 22"W X 28"H
20303014 8.5"W X 11"H

H) Exit Here Sign
20303015 22"W X 28"H
20303016 8.5"W X 11"H

I) Stand Here Floor Decal
20303017 12"W X 12"H

J) Directional Arrow Floor Decal
20303018 18"W X 24"H

Health & Safety

Sanitization Product & Services

Hand Sanitizing Stations

Using hand sanitizer reduces microbial counts and kills many harmful germs that could compromise the health of attendees with the COVID-19 and other viruses. Hand sanitizing stations provide convenient access to hand sanitizer after interactions where they happen.



1510103 Clear Barrier
(plexi, clear) 31.5"W x 36"H

Also available in opaque and personalization available.

1510100 Clear Barrier with graphic

Personalize here

Please Note:

Safety dividers also available in opaque finish. Graphics and branding options also available. View those options [here](#) and learn more about our SafeConnect Promise on [Freeman.com](#)

NAME OF SHOW: **JCK Las Vegas 2022 / June 10-13, 2022**

COMPANY NAME: _____ BOOTH #: _____

CONTACT NAME : _____ PHONE #: _____

E-MAIL ADDRESS : _____

Take advantage of the Online price by ordering at www.freeman.com/store by **MAY 09, 2022**.

Qty	Part #	Description	Online Price	Discount Price	Standard Price	Total
SOFT SEATING						
Naples Group - Black Vinyl						
_____	810119	Chair.....	576.50	634.15	807.10	_____
_____	830120	Loveseat.....	775.10	852.60	1,085.15	_____
_____	830119	Sofa.....	857.90	943.70	1,201.05	_____
Munich Group - Gray Fabric						
_____	810151	Armless Chair.....	603.15	663.45	844.40	_____
Baja Group - White Vinyl						
_____	81050	Chair.....	647.15	711.85	906.00	_____
_____	83020	Loveseat.....	711.95	783.15	996.75	_____
_____	83019	Sofa.....	1,011.80	1,113.00	1,416.50	_____
Valencia - Velvet						
_____	810180	Chair - Spice Orange.....	444.50	488.95	622.30	_____
_____	83045	Sofa - Coffee Brown.....	668.35	735.20	935.70	_____
Key Largo Group - Black Fabric						
_____	830950	Loveseat.....	624.80	687.30	874.70	_____
_____	830951	Sofa.....	689.80	758.80	965.70	_____
_____	810950	Chair.....	492.10	541.30	688.95	_____
Allegro Group - Blue Fabric						
_____	81019	Chair.....	584.65	643.10	818.50	_____
_____	83015	Sofa.....	933.05	1,026.35	1,306.25	_____
Fairfax Group - White Vinyl						
_____	810949	Chair.....	415.05	456.55	581.05	_____
_____	830949	Sofa.....	663.05	729.35	928.25	_____
Palm Beach - White Vinyl						
_____	83040	Sofa.....	763.10	839.40	1,068.35	_____
Sterling Group - Gray Fabric						
_____	81037	Chair.....	1,055.75	1,161.35	1,478.05	_____
_____	8309	Sofa.....	1,575.90	1,733.50	2,206.25	_____
Cordoba Group - Taupe/Black						
_____	81048	Chair.....	N/A	N/A	N/A	_____
_____	83013	Loveseat.....	N/A	N/A	N/A	_____

CASUAL SEATING

Ottomans						
_____	815122	Endless Square - White Vinyl.....	370.15	407.15	518.20	_____
_____	815123	Endless Square - Black Vinyl.....	370.15	407.15	518.20	_____
_____	815953	Endless Curve - White Vinyl.....	514.10	565.50	719.75	_____
_____	815952	Endless Curve - Black Vinyl.....	514.10	565.50	719.75	_____
_____	81518	Vibe Cube - Blue Vinyl.....	166.25	182.90	232.75	_____
_____	81519	Vibe Cube - Red Vinyl.....	166.25	182.90	232.75	_____
_____	81525	Vibe Cube - Orange Vinyl.....	166.25	182.90	232.75	_____
_____	81517	Vibe Cube - Yellow Vinyl.....	166.25	182.90	232.75	_____
_____	81530	Vibe Cube - Black Vinyl.....	149.25	164.20	208.95	_____
_____	81531	Vibe Cube - White Vinyl.....	149.25	164.20	208.95	_____

NAME OF SHOW: **JCK Las Vegas 2022 / June 10-13, 2022**

COMPANY NAME:

BOOTH #:

CONTACT NAME :

PHONE #:

E-MAIL ADDRESS :

Take advantage of the Online price by ordering at www.freeman.com/store by **MAY 09, 2022.**

furnishings

Qty	Part #	Description	Online Price	Discount Price	Standard Price	Total
Ottomans (continued)						
	81532	Vibe Cube - Steel Blue Vinyl.....	166.25	182.90	232.75	
	81533	Vibe Cube - Silver Vinyl.....	166.25	182.90	232.75	
	81534	Vibe Cube - Purple Vinyl.....	166.25	182.90	232.75	
	81535	Vibe Cube -Citrus Green Vinyl.....	171.35	188.50	239.90	
	81536	Vibe Cube - Taupe Vinyl.....	171.35	188.50	239.90	
	81537	Vibe Cube - Spice Orange Vinyl.....	118.30	130.15	165.60	
	81538	Vibe Cube - Desert Rose Vinyl.....	171.35	188.50	239.90	
	815151	Marche Swivel - Gray Fabric.....	N/A	N/A	N/A	
	815154	Marche Swivel - Red Fabric.....	263.95	290.35	369.55	
	815159	Marche Swivel - Blue Fabric.....	263.95	290.35	369.55	
	815152	Marche Swivel - Linen Fabric.....	263.95	290.35	369.55	
	815157	Marche Swivel - Meadow Green Fabric.....	263.95	290.35	369.55	
	815158	Marche Swivel - Pear Yellow Fabric.....	263.95	290.35	369.55	
	815156	Marche Swivel - Plum Fabric.....	263.95	290.35	369.55	
	815153	Marche Swivel - Raspberry Fabric.....	263.95	290.35	369.55	
	815155	Marche Swivel - Rose Quartz Fabric.....	263.95	290.35	369.55	
	815150	Marche Swivel - White Vinyl.....	N/A	N/A	N/A	
	815160	Marche Swivel - Orange Fabric.....	263.95	290.35	369.55	
	81540	Marche Swivel - Forest Green Vinyl.....	263.95	290.35	369.55	
	81541	Marche Swivel - Teal Velvet.....	263.95	290.35	369.55	
	81542	Marche Swivel - Distressed Brown Vinyl.....	263.95	290.35	369.55	
	81543	Marche Swivel - Black Vinyl.....	263.95	290.35	369.55	
	81539	Marche Swivel - Ivory Faux Sheep Fur.....	263.95	290.35	369.55	
Beverly Bench Ottomans						
	81550	Black Vinyl.....	512.80	564.10	717.90	
	81551	Brown Fabric.....	512.80	564.10	717.90	
	81552	Gray Fabric.....	512.80	564.10	717.90	
	81553	Linen Fabric.....	512.80	564.10	717.90	
	81554	Ocean Blue Fabric.....	512.80	564.10	717.90	
	81555	Red Fabric.....	512.80	564.10	717.90	
	81556	White Vinyl.....	512.80	564.10	717.90	
Beverly Small Bench Ottomans						
	81560	Black Vinyl.....	491.85	541.05	688.60	
	81561	Blue Fabric.....	491.85	541.05	688.60	
	81562	Brown Fabric.....	491.85	541.05	688.60	
	81563	Green Fabric.....	491.85	541.05	688.60	
	81565	Linen Fabric.....	491.85	541.05	688.60	
	81568	Red Fabric.....	491.85	541.05	688.60	
	81569	White Vinyl.....	491.85	541.05	688.60	
	81566	Lavender Fabric.....	491.85	541.05	688.60	
	81567	Orange Fabric.....	491.85	541.05	688.60	
	81564	Gray Fabric.....	491.85	541.05	688.60	
	81570	Yellow Fabric.....	491.85	541.05	688.60	
Accent Chairs						
	71089	Black Diamond Side Chair.....	92.65	101.90	129.70	
	71090	Black Diamond Arm Chair.....	96.65	106.30	135.30	
	810861	Laguna Chair - Maple/Chrome.....	157.85	173.65	221.00	

NAME OF SHOW: **JCK Las Vegas 2022 / June 10-13, 2022**

COMPANY NAME: _____ BOOTH #: _____

CONTACT NAME : _____ PHONE #: _____

E-MAIL ADDRESS : _____

Take advantage of the Online price by ordering at www.freeman.com/store by **MAY 09, 2022**.

Qty	Part #	Description	Online Price	Discount Price	Standard Price	Total
Accent Chairs (continued)						
	210108	Limerick® Chair by Herman Miller.....	65.55	72.10	91.75	
	810816	Madrid Chair - White Vinyl/Chrome.....	996.20	1,095.80	1,394.70	
	810948	Meeting Chair - White Vinyl.....	340.85	374.95	477.20	
	810164	Marina Chair - White Vinyl.....	176.65	194.30	247.30	
	810160	Marina Chair - Black Vinyl.....	176.65	194.30	247.30	
	810161	Marina Chair - Brown Fabric.....	176.65	194.30	247.30	
	810162	Marina Chair - Ocean Blue Fabric.....	176.65	194.30	247.30	
	810163	Marina Chair - Red Fabric.....	176.65	194.30	247.30	
	810131	Malba Chair - Gray Molded Plastic.....	117.30	129.05	164.20	
	810130	Malba Chair - Green Molded Plastic.....	114.80	126.30	160.70	
	810846	Christopher Chair - White Vinyl/Chrome.....	144.90	159.40	202.85	
	810851	Zenith Chair - White/Chrome.....	184.00	202.40	257.60	
	810841	Rustique Chair - Gunmetal.....	144.90	159.40	202.85	
	810837	Razor Armless Chair - White High Density Plastic.....	65.15	71.65	91.20	
	810875	Swanson Swivel Chair - White Vinyl.....	313.70	345.05	439.20	
	81083	Blade Chair - Sky Blue.....	97.35	107.10	136.30	
	81082	Blade Chair - Red.....	97.35	107.10	136.30	
	81093	Lucent Chair - Frosted Acrylic.....	245.10	269.60	343.15	
	810145	Wentworth Chair - Brown Vinyl.....	313.50	344.85	438.90	
	81024	Atherton Chair - Brown Leather.....	942.45	1,036.70	1,319.45	
	81034	Bowery Chair - Yellow Fabric.....	654.05	719.45	915.65	
	81035	Century Chair - Gray Velvet.....	633.45	696.80	886.85	
	81036	Lena Chair - Green Leather.....	798.25	878.10	1,117.55	
	81031	Montreal Chair - Blue Fabric.....	733.90	807.30	1,027.45	
	81032	Pasadena Chair - White Plastic.....	409.45	450.40	573.25	
	81038	Tech Chair - Gray Vinyl.....	486.70	535.35	681.40	
	81039	Tech Tablet Chair - Gray Vinyl.....	486.70	535.35	681.40	
	81046	Brooklyn Swivel Meeting Chair - White/Oak.....	N/A	N/A	N/A	
	81047	Brooklyn Swivel Meeting Chair - White/Black.....	N/A	N/A	N/A	
Executive Seating						
	71045	Gray Gaslift Chair Without Arms.....	222.45	244.70	311.45	
	810874	La Brea Swivel Chair - Charcoal Gray Fabric.....	424.75	467.25	594.65	
	810175	Genesis Chair - Black.....	481.35	529.50	673.90	
	810844	Pro Executive High Back Chair - White Vinyl.....	326.95	359.65	457.75	
	810946	Pro Executive High Back Chair - Black Vinyl.....	340.85	374.95	477.20	
	810945	Pro Executive Mid Back Chair - White Vinyl.....	423.10	465.40	592.35	
	810944	Pro Executive Mid Back Chair - Black Vinyl.....	410.35	451.40	574.50	
	810947	Pro Executive Guest Chair - Black Vinyl.....	442.80	487.10	619.90	
	810170	Cupertino Mid Back Chair - Black Vinyl.....	557.75	613.55	780.85	
Barstools						
	71088	Black Diamond Stool.....	183.70	202.05	257.20	
	71047	Gray Gaslift Stool without Arms.....	232.75	256.05	325.85	
	810860	Laguna Barstool - Maple/Chrome.....	199.20	219.10	278.90	
	210109	Limerick® Stool by Herman Miller.....	105.90	116.50	148.25	
	810872	Lift Barstool - Gray Vinyl/Chrome.....	190.15	209.15	266.20	
	810873	Lift Barstool - Red Vinyl/Chrome.....	190.15	209.15	266.20	

NAME OF SHOW: **JCK Las Vegas 2022 / June 10-13, 2022**

COMPANY NAME: _____ BOOTH #: _____

CONTACT NAME : _____ PHONE #: _____

E-MAIL ADDRESS : _____

furnishings

Take advantage of the Online price by ordering at www.freeman.com/store by **MAY 09, 2022.**

Qty	Part #	Description	Online Price	Discount Price	Standard Price	Total
Barstools (continued)						
_____	810871	Lift Barstool - Black Vinyl/Chrome.....	190.15	209.15	266.20	_____
_____	810870	Lift Barstool - White Vinyl/Chrome.....	190.15	209.15	266.20	_____
_____	810103	Banana Barstool - White Vinyl/Chrome.....	236.95	260.65	331.75	_____
_____	810104	Banana Barstool - Black Vinyl/Chrome.....	236.95	260.65	331.75	_____
_____	810850	Zenith Barstool - White/Chrome.....	184.00	202.40	257.60	_____
_____	810840	Zoey Barstool - White Vinyl/Chrome.....	346.20	380.80	484.70	_____
_____	810848	Christopher Barstool - White Vinyl/Chrome.....	253.00	278.30	354.20	_____
_____	810202	Shark Swivel Barstool - White Plastic/Chrome.....	391.80	431.00	548.50	_____
_____	810839	Rustique Barstool - Gunmetal.....	144.90	159.40	202.85	_____
_____	81080	Blade Barstool - Red.....	194.95	214.45	272.95	_____
_____	81081	Blade Barstool - Sky Blue.....	194.95	214.45	272.95	_____
_____	81092	Lucent Barstool - Frosted Acrylic.....	260.70	286.75	365.00	_____
_____	810135	Task Stool - Black Fabric.....	216.15	237.75	302.60	_____
_____	81026	Marina Barstool - Ocean Blue.....	339.90	373.90	475.85	_____
_____	81027	Marina Barstool - Black Vinyl.....	339.90	373.90	475.85	_____
_____	81028	Marina Barstool - Brown Fabric.....	339.90	373.90	475.85	_____
_____	81029	Marina Barstool - Red Fabric.....	339.90	373.90	475.85	_____
_____	81030	Marina Barstool - White Vinyl.....	339.90	373.90	475.85	_____

Draped Tables & Counters

Draped Tables - Tables are 24" wide
 Black Blue White Gray Red

_____	124330	Draped Table 3'L x 30"H.....	105.25	115.80	147.35	_____
_____	124430	Draped Table 4'L x 30"H.....	122.80	135.10	171.90	_____
_____	124630	Draped Table 6'L x 30"H.....	132.00	145.20	184.80	_____
_____	124830	Draped Table 8'L x 30"H.....	155.90	171.50	218.25	_____
_____	12404630	4th Side Drape 6'L x 30"H.....	47.65	52.40	66.70	_____
_____	12404830	4th Side Drape 8'L x 30"H.....	47.65	52.40	66.70	_____
_____	124342	Draped Counter 3'L x 42"H.....	127.15	139.85	178.00	_____
_____	124442	Draped Counter 4'L x 42"H.....	141.75	155.95	198.45	_____
_____	124642	Draped Counter 6'L x 42"H.....	155.90	171.50	218.25	_____
_____	124842	Draped Counter 8'L x 42"H.....	189.00	207.90	264.60	_____
_____	12404642	4th Side Drape 6'L x 42"H.....	54.90	60.40	76.85	_____
_____	12404842	4th Side Drape 8'L x 42"H.....	54.90	60.40	76.85	_____

Undraped Tables & Counters

_____	125330	Undraped Table 3'L x 30"H.....	38.35	42.20	53.70	_____
_____	125430	Undraped Table 4'L x 30"H.....	43.00	47.30	60.20	_____
_____	125630	Undraped Table 6'L x 30"H.....	47.65	52.40	66.70	_____
_____	125830	Undraped Table 8'L x 30"H.....	65.80	72.40	92.10	_____
_____	125342	Undraped Counter 3'L x 42"H.....	71.20	78.30	99.70	_____
_____	125442	Undraped Counter 4'L x 42"H.....	82.70	90.95	115.80	_____
_____	125642	Undraped Counter 6'L x 42"H.....	87.35	96.10	122.30	_____
_____	125842	Undraped Counter 8'L x 42"H.....	96.65	106.30	135.30	_____

Table Top Risers - Risers are 8" wide

_____	1504100	Black 4'L x 7"H Corrugated Riser.....	30.15	33.15	42.20	_____
_____	1504101	White 4'L x 7"H Corrugated Riser.....	30.15	33.15	42.20	_____
_____	1506100	Black 6'L x 7"H Corrugated Riser.....	35.30	38.85	49.40	_____
_____	1506101	White 6'L x 7"H Corrugated Riser.....	35.30	38.85	49.40	_____

NAME OF SHOW: **JCK Las Vegas 2022 / June 10-13, 2022**

COMPANY NAME: _____ BOOTH #: _____
 CONTACT NAME : _____ PHONE #: _____
 E-MAIL ADDRESS : _____

Take advantage of the Online price by ordering at www.freeman.com/store by MAY 09, 2022.

Qty	Part #	Description	Online Price	Discount Price	Standard Price	Total
Table Top Risers - Risers are 8" wide (continued)						
_____	1508100	Black 8'L x 7"H Corrugated Riser.....	40.70	44.75	57.00	_____
_____	1508101	White 8'L x 7"H Corrugated Riser.....	40.70	44.75	57.00	_____
_____	1504200	Black 4'L x 14"H Corrugated Riser.....	46.10	50.70	64.55	_____
_____	1504201	White 4'L x 14"H Corrugated Riser.....	46.10	50.70	64.55	_____
_____	1506200	Black 6'L x 14"H Corrugated Riser.....	56.40	62.05	78.95	_____
_____	1506201	White 6'L x 14"H Corrugated Riser.....	56.40	62.05	78.95	_____
_____	1508200	Black 8'L x 14"H Corrugated Riser.....	66.70	73.35	93.40	_____
_____	1508201	White 8'L x 14"H Corrugated Riser.....	66.70	73.35	93.40	_____
Pedestal Tables - Soho Series						
_____	72069	Black Top Cafe Table - 30"H x 24"W.....	172.10	189.30	240.95	_____
_____	72067	Black Top Cafe Table - 30"H x 36"W.....	198.60	218.45	278.05	_____
_____	72066	Black Top Mini Table - 18"H x 18"W.....	147.20	161.90	206.10	_____
_____	72070	Black Top Bistro Table - 42"H x 24"W.....	227.75	250.55	318.85	_____
_____	72068	Black Top Bistro Table - 42"H x 36"W.....	248.65	273.50	348.10	_____
Pedestal Tables - Chelsea Series						
_____	72063	Butcher Block Top Cafe Table - 30"H x 30"W.....	187.30	206.05	262.20	_____
_____	72064	Butcher Block Top Cafe Table - 30"H x 36"W.....	196.95	216.65	275.75	_____
_____	720163	Butcher Block Top Bistro Table - 42"H x 30"W.....	255.40	280.95	357.55	_____
_____	720164	Butcher Block Top Bistro Table - 42"H x 36"W.....	274.60	302.05	384.45	_____
Pedestal Tables						
_____	8201208	Hydraulic Base Cafe Table - Maple.....	398.40	438.25	557.75	_____
_____	8201207	Hydraulic Base Bar Table - Maple.....	414.15	455.55	579.80	_____
_____	8201209	Hydraulic Base Cafe Table - Graphite.....	442.85	487.15	620.00	_____
_____	8201211	Hydraulic Base Bar Table - Graphite.....	455.85	501.45	638.20	_____
_____	8201206	Hydraulic Base Cafe Table - Maple.....	453.05	498.35	634.25	_____
_____	8201205	Hydraulic Base Bar Table - Maple.....	450.20	495.20	630.30	_____
_____	820126	Hydraulic Base Cafe Table - White Laminate.....	453.05	498.35	634.25	_____
_____	820125	Hydraulic Base Bar Table - White Laminate.....	473.85	521.25	663.40	_____
_____	820241	Madison Hydraulic Base Cafe Table - Gray Acajou.	365.30	401.85	511.40	_____
_____	820240	Madison Hydraulic Base Bar Table - Gray Acajou...	365.30	401.85	511.40	_____
_____	820265	Madison Cafe Table - Gray Acajou.....	288.15	316.95	403.40	_____
_____	820264	Madison Bar Table - Gray Acajou.....	314.60	346.05	440.45	_____
_____	8201220	30" Cafe Table Black Base - White Laminate.....	297.75	327.55	416.85	_____
_____	8201221	30" Bar Table Black Base - White Laminate.....	318.55	350.40	445.95	_____
_____	8201222	30" Bar Table Chrome Base - White Laminate.....	458.15	503.95	641.40	_____
_____	8201223	30" Cafe Table Chrome Base - White Laminate.....	458.15	503.95	641.40	_____
_____	820920	30" Bar Table Chrome Hydraulic Base - Red.....	354.65	390.10	496.50	_____
_____	820921	30" Cafe Table Chrome Hydraulic Base - Red.....	354.65	390.10	496.50	_____
_____	820922	30" Bar Table Chrome Hydraulic Base - Graphite....	354.65	390.10	496.50	_____
_____	820923	30" Cafe Table Chrome Hydraulic Base - Graphite....	354.65	390.10	496.50	_____
_____	820930	30" Bar Table w/ Hydraulic Base - Blue.....	360.95	397.05	505.35	_____
_____	820931	30" Bar Table w/ Black Base - Blue.....	287.20	315.90	402.10	_____
_____	820932	30" Bar Table w/ Hydraulic Base - Wood.....	440.00	484.00	616.00	_____
_____	820933	30" Bar Table w/ Black Base - Wood.....	305.80	336.40	428.10	_____
_____	820940	30" Cafe Table w/ Hydraulic Base - Blue.....	360.95	397.05	505.35	_____
_____	820941	30" Cafe Table w/ Black Base - Blue.....	258.30	284.15	361.60	_____

NAME OF SHOW: **JCK Las Vegas 2022 / June 10-13, 2022**

COMPANY NAME: _____ BOOTH #: _____

CONTACT NAME : _____ PHONE #: _____

E-MAIL ADDRESS : _____

Take advantage of the Online price by ordering at www.freeman.com/store by **MAY 09, 2022**.

Qty	Part #	Description	Online Price	Discount Price	Standard Price	Total
Pedestal Tables (continued)						
_____	820942	30" Cafe Table w/ Hydraulic Base - Wood.....	440.00	484.00	616.00	_____
_____	820943	30" Cafe Table w/ Black Base - Wood.....	279.55	307.50	391.35	_____
_____	820910	30" Bar Table w/ Hydraulic Base - Gunmetal.....	473.70	521.05	663.20	_____
_____	820911	30" Bar Table w/ Hydraulic Base - Black.....	473.70	521.05	663.20	_____
_____	820912	30" Bar Table w/ Hydraulic Base - Green.....	473.70	521.05	663.20	_____
_____	820913	30" Bar Table w/ Hydraulic Base - Orange.....	473.70	521.05	663.20	_____
_____	820268	30" Bar Table w/ Hydraulic Base - Whiteboard.....	N/A	N/A	N/A	_____
_____	820914	30" Bar Table w/ Hydraulic Base - Yellow.....	473.70	521.05	663.20	_____
_____	820915	30" Bar Table w/ Black Base - Gunmetal.....	331.55	364.70	464.15	_____
_____	820916	30" Bar Table w/ Black Base - Black.....	331.55	364.70	464.15	_____
_____	820917	30" Bar Table w/ Black Base - Green.....	331.55	364.70	464.15	_____
_____	820918	30" Bar Table w/ Black Base - Orange.....	331.55	364.70	464.15	_____
_____	820919	30" Bar Table w/ Black Base - Yellow.....	331.55	364.70	464.15	_____
_____	820269	30" Bar Table w/ Black Base - Whiteboard.....	N/A	N/A	N/A	_____
_____	8201230	30" Cafe Table w/ Hydraulic Base - Gunmetal.....	473.70	521.05	663.20	_____
_____	8201231	30" Cafe Table w/ Hydraulic Base - Black.....	473.70	521.05	663.20	_____
_____	8201232	30" Cafe Table w/ Hydraulic Base - Green.....	473.70	521.05	663.20	_____
_____	8201233	30" Cafe Table w/ Hydraulic Base - Orange.....	473.70	521.05	663.20	_____
_____	8201234	30" Cafe Table w/ Hydraulic Base - Yellow.....	473.70	521.05	663.20	_____
_____	820270	30" Cafe Table w/ Hydraulic Base - Whiteboard.....	N/A	N/A	N/A	_____
_____	8201235	30" Cafe Table w/ Black Base - Gunmetal.....	307.90	338.70	431.05	_____
_____	8201236	30" Cafe Table w/ Black Base - Black.....	307.90	338.70	431.05	_____
_____	8201237	30" Cafe Table w/ Back Base - Green.....	307.90	338.70	431.05	_____
_____	8201238	30" Cafe Table w/ Black Base - Orange.....	307.90	338.70	431.05	_____
_____	8201239	30" Cafe Table w/ Black Base - Yellow.....	307.90	338.70	431.05	_____
_____	820271	30" Cafe Table w/ Black Base - Whiteboard.....	N/A	N/A	N/A	_____
_____	8201240	36" Bar Table w/ Hydraulic Base - Black.....	492.00	541.20	688.80	_____
_____	8201241	36" Bar Table w// Black Base - Black.....	336.85	370.55	471.60	_____
_____	8201242	36" Cafe Table w/ Hydraulic Base - Black.....	468.40	515.25	655.75	_____
_____	8201243	36" Cafe Table w/ Black Base - Black.....	360.45	396.50	504.65	_____
_____	820273	36" Bar Table w/ Black Base - Whiteboard.....	N/A	N/A	N/A	_____
_____	820272	36" Bar Table w/ Hydraulic Base - Whiteboard.....	N/A	N/A	N/A	_____
_____	820267	36" Cafe Table w/ Black Base - Whiteboard.....	N/A	N/A	N/A	_____
_____	820274	36" Cafe Table w/ Hydraulic Base - Whiteboard.....	N/A	N/A	N/A	_____
Accent Tables						
_____	82015	Silverado End Table - Tempered Glass/Painted Steel.....	318.75	350.65	446.25	_____
_____	82014	Silverado Cocktail Table - Tempered Glass/Painted Steel.....	338.65	372.50	474.10	_____
_____	820252	Alondra End Table - Glass/Chrome.....	266.70	293.35	373.40	_____
_____	820250	Alondra Cocktail Table - Glass/Chrome.....	370.25	407.30	518.35	_____
_____	820253	Alondra End Table - Wood/Chrome.....	266.70	293.35	373.40	_____
_____	820251	Alondra Cocktail Table - Wood/Chrome.....	370.25	407.30	518.35	_____
_____	8201224	Atomic 36" Round Table - Glass/Chrome.....	398.85	438.75	558.40	_____
_____	8201225	Atomic 42" Round Table - Glass/Chrome.....	398.85	438.75	558.40	_____
_____	82028	Geo End Table - Wood/Black Steel.....	314.60	346.05	440.45	_____
_____	82027	Geo Cocktail Table - Wood/Black Steel.....	323.00	355.30	452.20	_____

NAME OF SHOW: **JCK Las Vegas 2022 / June 10-13, 2022**

COMPANY NAME:

BOOTH #:

CONTACT NAME :

PHONE #:

E-MAIL ADDRESS :

Take advantage of the Online price by ordering at www.freeman.com/store by **MAY 09, 2022.**

Qty	Part #	Description	Online Price	Discount Price	Standard Price	Total
	82035	Geo End Table - Glass/Chrome.....	288.95	317.85	404.55	
	82034	Geo Cocktail Table - Glass/Chrome.....	318.75	350.65	446.25	
	82054	Sydney End Table - Black Laminate/Brushed Steel..	291.90	321.10	408.65	
	82055	Sydney End Table - White Laminate/Brushed Steel..	291.90	321.10	408.65	
	82052	Sydney Cocktail Table - Black Laminate/Brushed Steel.....	352.45	387.70	493.45	
	82053	Sydney Cocktail Table - White Laminate/Brushed Steel.....	352.45	387.70	493.45	
	82079	Sydney End Table - Blue Laminate/Brushed Steel....	281.90	310.10	394.65	
	82080	Sydney End Table - Wood Laminate/Brushed Steel..	281.90	310.10	394.65	
	82077	Sydney Cocktail Table - Blue Laminate/Brushed Steel.....	339.75	373.75	475.65	
	82078	Sydney Cocktail Table - Wood Laminate/Brushed Steel.....	339.75	373.75	475.65	
	82075	Regis End Table - Brushed Metal.....	288.35	317.20	403.70	
	82074	Regis Bench Table - Brushed Metal.....	406.35	447.00	568.90	
	820844	Aura Round Table - White Metal.....	153.00	168.30	214.20	
	82043	Geo Square-Round Table - Glass/Black Steel.....	373.25	410.60	522.55	
	82044	Geo Square-Round Table - Glass/Chrome.....	373.25	410.60	522.55	
	8201226	Rustique Square Metal Bar Table - Gray.....	352.10	387.30	492.95	
	820130	Mesa Cocktail Table - Black/Bronze.....	347.15	381.85	486.00	
	820131	Mesa Cocktail Table - Glass/Bronze.....	347.15	381.85	486.00	
	820132	Mesa Cocktail Table - Wood/Bronze.....	347.15	381.85	486.00	
	820133	Mesa End Table - Black/Bronze.....	310.60	341.65	434.85	
	820134	Mesa End Table - Glass/Bronze.....	310.60	341.65	434.85	
	820135	Mesa End Table - Wood/Bronze.....	310.60	341.65	434.85	
	820310	Sedona Side Table - Black/Bronze.....	257.80	283.60	360.90	
	820311	Sedona Side Table - Wood/Bronze.....	257.80	283.60	360.90	
	820312	Sedona Side Table - White/Bronze.....	257.80	283.60	360.90	
	820320	Taos Side Table - Black/Bronze.....	257.80	283.60	360.90	
	820321	Taos Side Table Wood/Bronze.....	257.80	283.60	360.90	
	820322	Taos Side Table - White/Bronze.....	257.80	283.60	360.90	
Conference Tables						
	82041	Geo Conference Table - Glass/Black Steel.....	538.20	592.00	753.50	
	82051	Geo Conference Table - Glass/Chrome.....	538.20	592.00	753.50	
	820260	Madison Conference Table - Gray Acajou.....	493.50	542.85	690.90	
	820708	42" Round Conference Table - White Laminate.....	479.95	527.95	671.95	
	820261	Madison 5' Conference Table - Gray Acajou.....	484.00	532.40	677.60	
	820262	Madison 8' Conference Table - Gray Acajou.....	1,191.85	1,311.05	1,668.60	
	820263	Madison 10' Conference Table - Gray Acajou.....	1,191.85	1,311.05	1,668.60	
	820951	Ventura Bar Table - Maple w/ Grommets.....	823.40	905.75	1,152.75	
	820952	Ventura Communal Bar Table - Black.....	849.30	934.25	1,189.00	
	820953	Ventura Bar Table - White w/ Grommets.....	823.40	905.75	1,152.75	
	820954	Ventura Communal Bar Table - Maple.....	823.40	905.75	1,152.75	
	820956	Ventura Communal Bar Table - White.....	823.40	905.75	1,152.75	
	820963	Ventura Communal Cafe Table - Maple.....	598.05	657.85	837.25	
	820960	Ventura Cafe Table - Maple w/ Grommets.....	838.10	921.90	1,173.35	
	820961	Ventura Cafe Table - White w/ Grommets.....	838.10	921.90	1,173.35	

furnishings

NAME OF SHOW: **JCK Las Vegas 2022 / June 10-13, 2022**

COMPANY NAME: _____ BOOTH #: _____

CONTACT NAME : _____ PHONE #: _____

E-MAIL ADDRESS : _____

Take advantage of the Online price by ordering at www.freeman.com/store by **MAY 09, 2022.**

Qty	Part #	Description	Online Price	Discount Price	Standard Price	Total
	820966	Ventura Communal Cafe Table - White.....	598.05	657.85	837.25	
	820962	Ventura Communal Cafe Table - Black.....	598.05	657.85	837.25	
	8201244	42" Round Conference Table - Black Laminate.....	489.35	538.30	685.10	
	8201	10' Table - Black Laminate.....	1,040.30	1,144.35	1,456.40	
	8203	5' Table - Black Laminate.....	535.60	589.15	749.85	
	8205	8' Table - Black Laminate.....	782.80	861.10	1,095.90	
Office						
	84075	Madison Desk - Gray Acajou.....	711.80	783.00	996.50	
	84078	Madison Bookcase - Gray Acajou.....	506.60	557.25	709.25	
Computer Desks/Tables						
	820706	Work Desk - White Laminate.....	412.75	454.05	577.85	

POWERED

Powered Seating

	810120	Naples Chair, Powered - Black Vinyl.....	767.40	844.15	1,074.35	
	830122	Naples Loveseat, Powered - Black Vinyl.....	1,031.80	1,135.00	1,444.50	
	830121	Naples Sofa, Powered - Black Vinyl.....	1,187.10	1,305.80	1,661.95	

Powered Tables

	820950	Ventura Communal Bar Table, Powered - Black.....	1,050.90	1,156.00	1,471.25	
	820955	Ventura Communal Bar Table, Powered - White.....	955.35	1,050.90	1,337.50	
	820964	Ventura Communal Cafe Table, Powered - Black.....	743.15	817.45	1,040.40	
	820965	Ventura Communal Cafe Table, Powered - White.....	743.15	817.45	1,040.40	
	84083	Tech Desk w/ 3 Drawer File Cabinet, Powered - Black Metal.....	747.80	822.60	1,046.90	
	84084	Tech Desk, Powered - Black Metal.....	658.50	724.35	921.90	
	82076	Sydney Cocktail Table, Powered - Black.....	508.85	559.75	712.40	
	82073	Sydney Cocktail Table, Powered - White.....	508.85	559.75	712.40	
	8202	10' Table, Powered - Black Laminate.....	1,300.40	1,430.45	1,820.55	
	8204	5' Table, Powered - Black Laminate.....	672.10	739.30	940.95	
	8206	8' Table, Powered - Black Laminate.....	1,300.40	1,430.45	1,820.55	

Powered Pedestals

	85060	Powered Locking Pedestal 36" H, Black.....	561.05	617.15	785.45	
	85061	Powered Locking Pedestal 36" H, White.....	561.05	617.15	785.45	
	85062	Powered Locking Pedestal 42" H, Black.....	668.90	735.80	936.45	
	85063	Powered Locking Pedestal 42" H, White.....	668.90	735.80	936.45	
	820710	Wireless Charging Table, Powered.....	593.00	652.30	830.20	

Midtown Counters & Bars

	850103	Midtown Powered Counter Unlighted - Pewter.....	1,897.40	2,087.15	2,656.35	
	850102	Midtown Powered Counter Lighted w/ Plug-In - Pewter.....	2,208.55	2,429.40	3,091.95	
	850101	Midtown Bar Unlighted - Pewter.....	1,699.80	1,869.80	2,379.70	
	850100	Midtown Bar Lighted w/ Plug-In - Pewter.....	2,018.65	2,220.50	2,826.10	

DISPLAY & ACCESSORIES

Product Storage

	84080	3 Door File Cabinet on Castors - Black	228.10	250.90	319.35	
	85020	Posh Shelving w/ Chrome Frame - White.....	639.25	703.20	894.95	

NAME OF SHOW: **JCK Las Vegas 2022 / June 10-13, 2022**

COMPANY NAME: _____ BOOTH #: _____

CONTACT NAME : _____ PHONE #: _____

E-MAIL ADDRESS : _____

Take advantage of the Online price by ordering at www.freeman.com/store by **MAY 09, 2022.**

Qty	Part #	Description	Online Price	Discount Price	Standard Price	Total
Refrigerator						
_____	8503001	Refrigerator - White.....	986.30	1,084.95	1,380.80	_____
_____	8983000	Small Refrigerator.....	N/A	N/A	N/A	_____
Lighting						
_____	850707	Mason Table Lamp - White/Brushed Silver.....	182.25	200.50	255.15	_____
_____	850708	Mason Floor Lamp - White/Brushed Silver.....	270.95	298.05	379.35	_____
Display						
_____	75030	Display Cube - Black - 12" Small.....	232.75	256.05	325.85	_____
_____	75031	Display Cube - Black - 18" Medium.....	232.75	256.05	325.85	_____
_____	75032	Display Cube - Black - 24" Large.....	232.75	256.05	325.85	_____
_____	72056	Display Counter - Black.....	418.90	460.80	586.45	_____
Boxwood Hedges						
_____	85030	7' Boxwood Hedge.....	640.00	704.00	896.00	_____
_____	85035	4' Boxwood Hedge.....	350.00	385.00	490.00	_____
Accessories						
_____	220121	Chrome Stanchion w/ 8' Retractable Belt.....	82.45	90.70	115.45	_____
_____	220118	Chrome Sign Holder.....	87.70	96.45	122.80	_____
_____	750135	Round Literature Rack.....	338.95	372.85	474.55	_____
_____	750136	Flat Literature Rack.....	338.95	372.85	474.55	_____
_____	220109	Chrome Coat Tree.....	59.90	65.90	83.85	_____
_____	220134	Aluminum Easel.....	50.25	55.30	70.35	_____
_____	220110	Chrome Bag Rack.....	123.75	136.15	173.25	_____
_____	10201484	Floor Standing Bulletin Board.....	215.55	237.10	301.75	_____
_____	220106	Corrugated Wastebasket.....	13.90	15.30	19.45	_____
_____	8502	Village Charging Hub.....	327.05	359.75	457.85	_____
Special Drape						
<input type="checkbox"/> Black <input type="checkbox"/> Blue <input type="checkbox"/> White <input type="checkbox"/> Gray <input type="checkbox"/> Red						
_____	12103	Special Drape 3'H (per ft.).....	17.85	19.65	25.00	_____
_____	12108	Special Drape 8'H (per ft.).....	23.80	26.20	33.30	_____

TOTAL COST

Total Cost = \$ _____

Applicable taxes will be applied to your order and invoiced accordingly based on specific venue jurisdiction but may also be based on the jurisdiction of where services are performed or your headquarters.

furnishings

Freeman¹

Flooring solutions

Stand out in style.

Visit us at freeman.com



© 2021 Freeman. All Rights Reserved.



Your exhibit's flooring should complement your brand

- The largest selection of exhibit flooring in the industry with a wide choice of colors and sizes
- New vinyl and turf solutions added to broaden your options and freshen your space
- Colorfast carpeting boasts a consistent shade every time
- All carpet and padding is manufactured with 100% recycled material
- Rental prices include delivery, installation, carpet removal and material handling fees

Most popular flooring options

Freeman offers the widest selection of flooring options, ensuring you can take your booth to the next level.

Choose from varying carpet weights to fit your level of comfort and durability or stand out with vinyl and turf.

Continue reading for more detail on each flooring option.

Be sure to order before the discount deadline!

Ordering early gives you access to a wider selection of products at discounted prices, saving you time and money so you can rest at ease.

▼ = Available only before the discount deadline

Classic Collection

16oz carpet

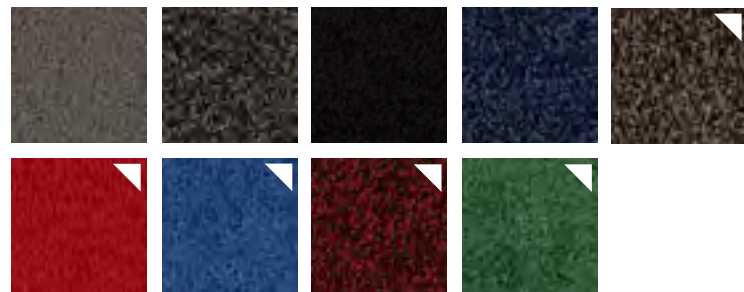

Designer Plus Collection

30oz carpet

NEW

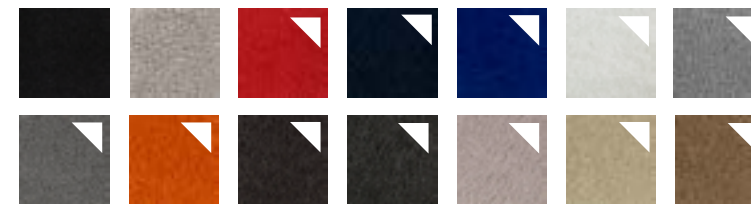

Supreme Collection

45oz carpet

NEW

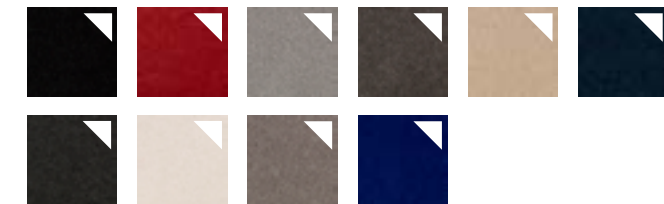

Expo Flex Collection

10ft vinyl

NEW



Event Flex Collection

12ft vinyl

NEW

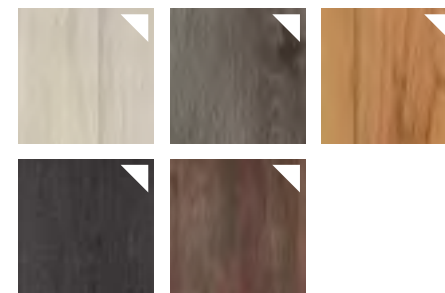

Riviera + Parkside Collections

Turf

NEW

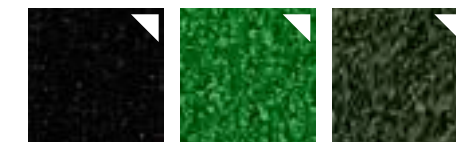

Classic Collection

16oz

- Best value and best seller
- Available in 10ft width and in the most common exhibit spaces including 10x10, 10x20, and 10x30
- 100% recyclable
- For extra comfort, add padding for an additional fee

For fast, easy ordering, visit us at freeman.com/find-show



Gray



Tuxedo



Black

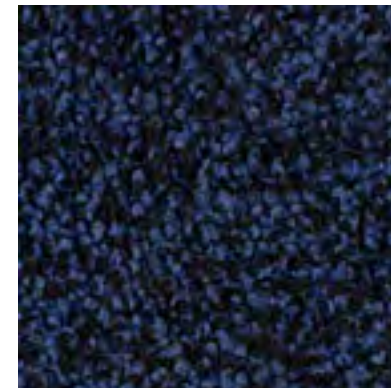

Midnight



Blue



Red

▽ = Available only before the discount deadline

Custom Cut Classic Collection

16oz

- 10ft width and custom cut to size
- Priced per sq.ft., minimum of 100 sq.ft.
- 100% recyclable
- Exhibit spaces are protected with Visqueen plastic floor covering
- For extra comfort, add padding for an additional fee



Gray



Tuxedo



Black

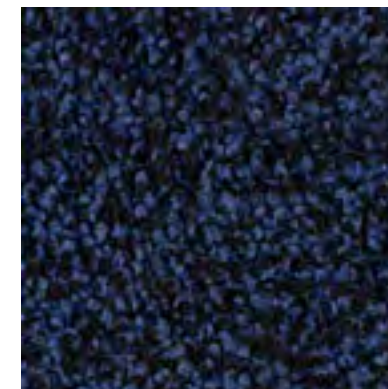

Midnight

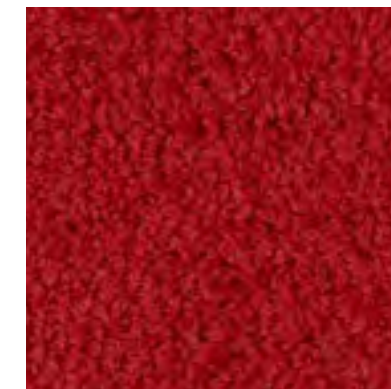

Red



Blue



Latte



Red Pepper



Green

▼ = Available only before the discount deadline

NEW

Designer Plus Collection

30oz

- Step up the comfort and durability with the Designer plus carpet
- 10ft width designed and cut to size
- Priced per sq.ft., minimum of 100 sq.ft.
- 100% recyclable
- Exhibit spaces are protected with Visqueen plastic floor covering
- For extra comfort, add padding for an additional fee

For fast, easy ordering, visit us at freeman.com/find-show



Black

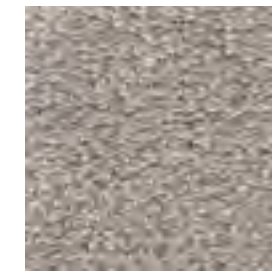

Grey Pearl



Red



Navy

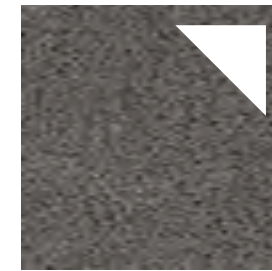

Lava Rock

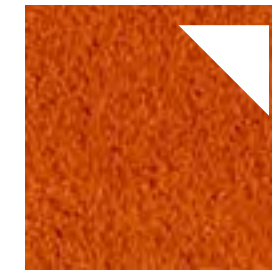

Paprika



Graphite

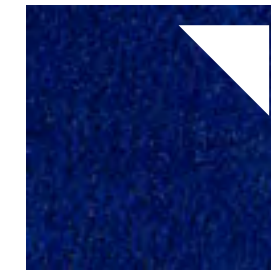

Royal Blue



Silky Beige



Ivory



Smoke



Sword



White

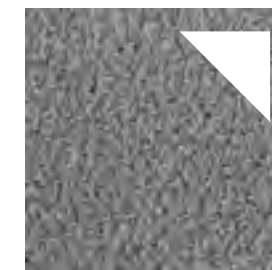

Silver Cloud

▼ = Available only before the discount deadline

NEW

Supreme Collection

45oz

- The most plush flooring option with added durability
- 10ft width designed and cut to size
- Priced per sq.ft., minimum of 100 sq.ft.
- 100% recyclable
- Exhibit spaces are protected with Visqueen plastic floor covering
- For extra comfort, add padding for an additional fee



Black



Red



Silver Cloud



Navy



Charcoal



Reflex Blue



Cream



Silver Mist



Smoke



White

▼ = Available only before the discount deadline

Ordering after the discount deadline? Don't fret.

You can select from these options.

For fast, easy ordering, visit us at freeman.com/find-show

Classic Collection

16oz



Gray



Tuxedo



Black



Midnight

Custom Cut Classic Collection

16oz



Gray



Tuxedo



Black



Midnight



Red

Designer Plus Collection

30oz

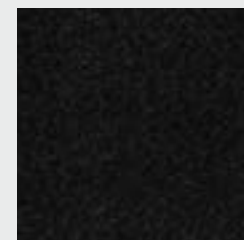

Black



Gray Pearl



Want to try something other than carpet? We have it!

Now offering vinyl and turf flooring solutions.

NEW

Expo Vinyl Collection

- Get the upgraded appearance of wood or tile
- Standard 10ft width and can be custom cut to size
- Great for exhibit spaces in common sizes of 10x10, 10x20 and 10x30
- Priced per sq.ft., minimum of 100 sq.ft.
- 100% recyclable
- For extra comfort, add padding for an additional fee



Birch



Light Maple



Dark Maple



Ash



Smoke

▼ = Available only before the discount deadline

NEW

Event Flex Collection

- Get the look of classic wood, tile, or laminate – with easier installation
- 12ft width designed and cut to size
- Great for island exhibit spaces or aisle flooring designs
- Priced per sq.ft., minimum of 100 sq.ft.
- 100% recyclable
- For extra comfort, add padding for an additional fee

For fast, easy ordering, visit us at freeman.com/find-show



Whitewood



Silverwood



Dark Maple



Blackwood



Barnwood

▼ = Available only before the discount deadline

NEW

Turf

- Bring the outdoors to you with these synthetic grass flooring solutions
- Available in many shades of green and durable for both indoor and outdoor use
- Standard 12ft width and can be custom cut to size
- Priced per sq.ft., minimum of 100 sq.ft.

For fast, easy ordering, visit us at freeman.com/find-show

Riviera synthetic grass brings an outdoor feel to your event space. Optimized for durability and resistance that is ideal for indoor or outdoor use.

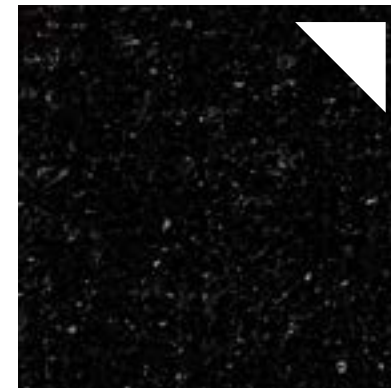

Riviera Black

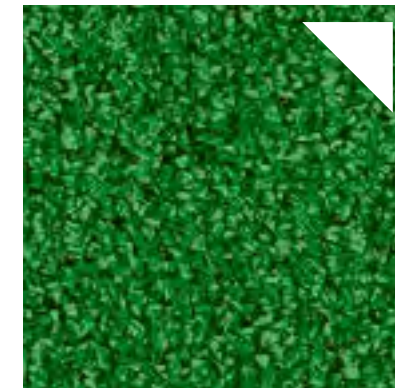

Riviera Green

Parkside Parkside high-quality synthetic grass provides the real look and feel of your backyard. Colorfast and UV technology makes this the most durable turf solution for both indoor and outdoor use.

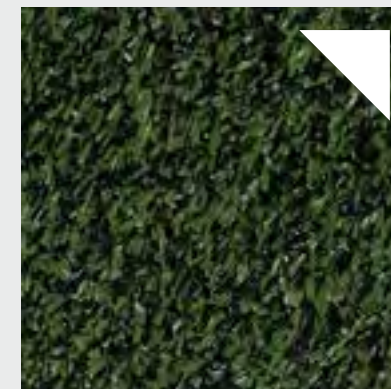

Parkside Green

▼ = Available only before the discount deadline

Want to take your flooring to the next level?

Custom flooring options can be ordered for borders, patterns, logos and specific sizes. Contact your Freeman Sales Team member for more information about specialty and custom flooring selections.

Contact solutions@freeman.com



Freeman¹

Order before the discount deadline.

Ordering early gives you access to a wider selection of products at discounted prices, saving you time and money so you can rest at ease.

freeman.com/find-show

Visit us at freeman.com or contact us at freeman.com/contact



© 2021 Freeman. All Rights Reserved.

NAME OF SHOW: **JCK Las Vegas 2022 / June 10-13, 2022**

COMPANY NAME: _____ BOOTH #: _____

CONTACT NAME: _____ PHONE #: _____

E-MAIL ADDRESS: _____

Take advantage of the Online Price by ordering at www.freeman.com/store by **MAY 9, 2022**.

PACKAGE CARPET REMOVAL

Reminder: Black booth carpet is provided as part of your JCK Exhibitor Package. If you have a CUSTOM exhibit and wish to have a different carpet or flooring, please see below for instructions. Freeman package booths MUST use the carpet provided by show management.

**CUSTOM BOOTHS
(MUST be approved by Show Management)**

- Exhibitors bringing their own carpet may lay their carpet on top of the booth carpet.

OR

- Exhibitors wishing to have the booth carpet removed must complete and return this form to Freeman by **May 9, 2022** to have the package carpet removed at **NO CHARGE**.

PLEASE REMOVE THE PACKAGE CARPET PROVIDED.

- **Orders received after May 9, 2022 or during move-in will be charged \$1.60 per square foot for carpet removal.**
- There will be a minimum charge of 100 square feet per removal request.

PACKAGE CARPET REMOVAL ORDER

Booth Carpet Removal - Price per sq. ft. (100 sq. ft. minimum)

Per sq. ft.	Booth Size: _____ x _____ = _____ sq.ft. @	Price per sqft by May 9, 2022	Price per sqft after May 9, 2022	Total
		\$ 0.00	\$ 1.60	\$ _____

TOTAL COST

Total Cost = \$ _____

Applicable taxes will be applied to your order and invoiced accordingly based on specific venue jurisdiction but may also be based on the jurisdiction of where services are performed or your headquarters.

NAME OF SHOW: **JCK Las Vegas 2022 / June 10-13, 2022**

COMPANY NAME: _____ BOOTH #: _____

CONTACT NAME : _____ PHONE #: _____

E-MAIL ADDRESS : _____

Take advantage of the Online Price by ordering at www.freeman.com/store by MAY 09, 2022.

FLOORING

- Orders received after the deadline date or without payment will be charged the Standard Price and are subject to availability.
- Products or colors with limited availability after the discount deadline are denoted with an asterisk *
- All utility lines must be installed before carpet installation. Utilities should be ordered in advance.
- Pricing includes delivery, material handling, installation and removal.
- All carpets, padding and plastic covering contain recycled content and are recyclable.

10' Classic Carpet, Padding & Plastic Covering

CHOOSE YOUR CARPET COLOR:

- Black Blue* Gray Midnight Blue Red* Tuxedo

Qty	Description	Online Price	Discount Price	Standard Price	Total
_____	10' x 10' Classic Carpet	\$ 178.35	\$ 196.20	\$ 249.70	_____
_____	10' x 20' Classic Carpet	\$ 356.70	\$ 392.35	\$ 499.40	_____
_____	10' x 30' Classic Carpet	\$ 535.05	\$ 588.55	\$ 749.05	_____
_____	10' x 10' Carpet Padding - Single Layer.....	\$ 85.90	\$ 94.50	\$ 120.25	_____
_____	10' x 20' Carpet Padding - Single Layer.....	\$ 171.80	\$ 189.00	\$ 240.50	_____
_____	10' x 30' Carpet Padding - Single Layer.....	\$ 257.70	\$ 283.45	\$ 360.80	_____
_____	10' x 10' Carpet Padding - Double Layer.....	\$ 171.80	\$ 189.00	\$ 240.50	_____
_____	10' x 20' Carpet Padding - Double Layer.....	\$ 343.60	\$ 377.95	\$ 481.05	_____
_____	10' x 30' Carpet Padding - Double Layer.....	\$ 515.40	\$ 566.95	\$ 721.55	_____
_____	Plastic Covering (price per sqft).....	\$ 1.40	\$ 1.55	\$ 1.95	_____

Custom Cut Classic Carpet

- Order Custom Cut Classic Carpeting by the sqft if your size is not listed on the standard size order form.
- Pricing includes plastic covering, delivery, material handling, installation and removal.

CHOOSE YOUR CARPET COLOR:

- Black Blue* Gray Green* Latte* Midnight Red* Red pepper* Tuxedo

16 oz. Carpet Rental - Price per sqft (100 sqft minimum)

Per sqft	Booth Size: _____ x _____ = _____ sqft	Online Price	Discount Price	Standard Price	Total
		\$ 3.60	\$ 3.95	\$ 5.05	_____

Vinyl*

- Pricing includes delivery, material handling, installation and removal.

10 ft Expo Event Vinyl, choose your flooring color:

- Ash Birch Dark Maple Light Maple Smoke

10 ft wide Vinyl - Price per sqft (100 sqft minimum)

Per sqft	Booth Size: _____ x _____ = _____ sqft	Online Price	Discount Price	Standard Price	Total
		\$ 7.80	\$ 8.60	\$ 10.90	_____

12 ft Event Flex Vinyl, choose your flooring color:

- Barnwood Blackwood Dark Maple Silverwood Whitewood

12 ft wide Vinyl - Price per sqft (100 sqft minimum)

Per sqft	Booth Size: _____ x _____ = _____ sqft	Online Price	Discount Price	Standard Price	Total
		\$ 9.75	\$ 10.75	\$ 13.65	_____

NAME OF SHOW: **JCK Las Vegas 2022 / June 10-13, 2022**

COMPANY NAME: _____ BOOTH #: _____

CONTACT NAME : _____ PHONE #: _____

E-MAIL ADDRESS : _____



Upgraded Carpet*

• Pricing includes plastic covering, delivery, material handling, installation and removal.

30 oz Designer Plus Carpet, choose your carpet color:

- Black Graphite* Gray Pearl Ivory* Lava Rock* Navy* Paprika* Red* Royal Blue* Silky Beige*
 Silver Cloud Smoke* Sword* White*

30 oz. Carpet Rental - Price per sq. ft. (100 sqft minimum)

				Online Price	Discount Price	Standard Price	Total
1 - 700 sqft	Booth Size: _____ x _____ = _____	sqft	\$	6.20	\$ 6.80	\$ 8.70	_____
Over 700 sqft	Booth Size: _____ x _____ = _____	sqft	\$	5.60	\$ 6.15	\$ 7.85	_____

45 oz Supreme Carpet, choose your carpet color:

- Black* Charcoal* Cream* Navy* Red* Reflex Blue* Silver Cloud* Silver Mist* Smoke* White*

45 oz. Carpet Rental - Price per sq. ft. (100 sqft minimum)

				Online Price	Discount Price	Standard Price	Total
1 - 700 sqft	Booth Size: _____ x _____ = _____	sqft	\$	7.10	\$ 7.80	\$ 9.95	_____
Over 700 sqft	Booth Size: _____ x _____ = _____	sqft	\$	6.40	\$ 7.05	\$ 8.95	_____



Carpet Padding

• Pricing includes delivery, material handling, installation and removal.

• Order padding by the sqft if your size is not listed on the standard size order form.

Carpet Padding- Price per sqft (100 sqft minimum)

				Online Price	Discount Price	Standard Price	Total
100 - 700 sqft	Booth Size: _____ x _____ = _____	sqft	\$.95	\$ 1.05	\$ 1.35	_____
Over 700 sqft	Booth Size: _____ x _____ = _____	sqft	\$.70	\$.75	\$ 1.00	_____

Double Carpet Padding- Price per sqft. (100 sqft minimum)

				Online Price	Discount Price	Standard Price	Total
100 - 700 sqft	Booth Size: _____ x _____ = _____	sqft	\$	1.90	\$ 2.10	\$ 2.65	_____
Over 700 sqft	Booth Size: _____ x _____ = _____	sqft	\$	1.40	\$ 1.55	\$ 1.95	_____

Vinyl Flooring Padding - Price per sqft (100 sqft minimum)

				Online Price	Discount Price	Standard Price	Total
Per sqft	Booth Size: _____ x _____ = _____	sqft	\$	4.70	\$ 5.15	\$ 6.60	_____

Turf*

• Pricing includes delivery, material handling, installation and removal.

Riviera Turf, choose your color:

- Black Ivy Green

Riviera Turf - Price per sqft (100 sqft minimum)

				Online Price	Discount Price	Standard Price	Total
Per sqft	Booth Size: _____ x _____ = _____	sqft	\$	5.70	\$ 6.25	\$ 8.00	_____

Parkside Turf, choose your color:

- Green

Parkside Landscape Turf - Price per sqft (100 sqft minimum)

				Online Price	Discount Price	Standard Price	Total
Per sqft	Booth Size: _____ x _____ = _____	sqft	\$	11.70	\$ 12.85	\$ 16.40	_____

TOTAL COST

Total Cost = \$ _____

Applicable taxes will be applied to your order and invoiced accordingly based on specific venue jurisdiction but may also be based on the jurisdiction of where services are performed or your headquarters.

Standard Exhibitor Booth Package

2022

JCK | LAS VEGAS

The location of your booth is in a neighborhood that requires a booth display that meets the new visual branding guidelines set forth for the show (review full JCK Visual Branding Guidelines on other attachment in this mailing). You can make the selection of either bringing a custom booth that you own (which must be approved by JCK Show Management by April 1, 2022. Find out more on JCK Visual Branding Guidelines attachment) or you will need to utilize the standard exhibitor booth package for your designated neighborhood shown below.



10'x10'
Corner Left

DISCOUNT PRICE: \$2,032.68
Regular Price: \$2,644.82



10'x10'
Corner Right

DISCOUNT PRICE: \$2,032.68
Regular Price: \$2,644.82



10'x10' Angle
Corner Left

DISCOUNT PRICE: \$2,507.97
Regular Price: \$3,081.91

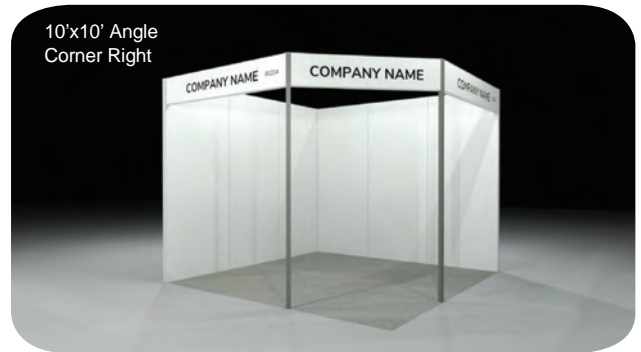

10'x10' Angle
Corner Right

DISCOUNT PRICE: \$2,507.97
Regular Price: \$3,081.91



10'x10' Inline

DISCOUNT PRICE: \$2,245.93
Regular Price: \$2,914.29



ORDER FORM, HEADER FORM, AND ADVANCED PAYMENT MUST BE RECEIVED BY DEADLINE DATE.

Packages Include:

- Wall Structure: White PVC side and back walls with silver metal frame (Contact your Freeman Sales Representative regarding graphic wall and shelving upgrade options)
- Graphic Header: Including your company name, booth number, and neighborhood icon (Company name will be printed from directory listing.)
- Carpet Provided by JCK Show Management (No Substitutions)
- First Night Cleaning
- Power for Showcases: Provided by JCK Show Management, 1000 Watts for 80 & 100 Sq. Ft. & 2000 Watts for 200 Sq. Ft.
- Drayage and Labor for installation and removal of structure included

Please Note: The required chrome showcases for the standard booth are not included in this package and will need to be ordered through American Fixture. *State Sales Tax of 8.375% will be added

**For Referral to a Sales Representative, please email:
JCKexhibits@freeman.com**

Standard Exhibitor Booth Package

2022

JCK | LAS VEGAS

The location of your booth is in a neighborhood that requires a booth display that meets the new visual branding guidelines set forth for the show (review full JCK Visual Branding Guidelines on other attachment in this mailing). You can make the selection of either bringing a custom booth that you own (which must be approved by JCK Show Management by April 1, 2022. Find out more on JCK Visual Branding Guidelines attachment) or you will need to utilize the standard exhibitor booth package for your designated neighborhood shown below.



10'x15'
Corner Left

DISCOUNT PRICE: \$2,627.85
Regular Price: \$3,416.20

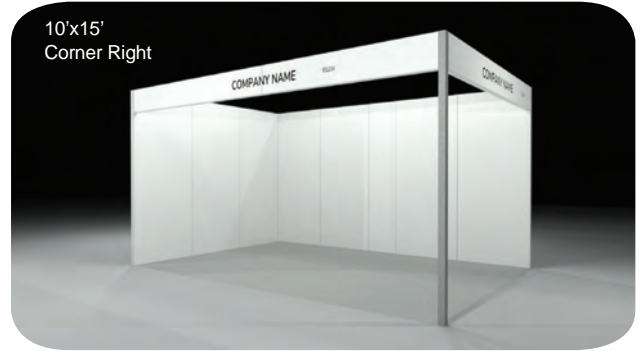

10'x15'
Corner Right

DISCOUNT PRICE: \$2,627.85
Regular Price: \$3,416.20



10'x15' Angle
Corner Left

DISCOUNT PRICE: \$3,212.41
Regular Price: \$4,176.13

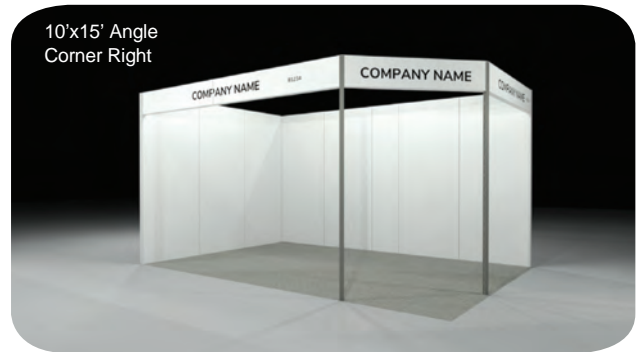

10'x15' Angle
Corner Right

DISCOUNT PRICE: \$3,212.41
Regular Price: \$4,176.13



10'x15' Inline

DISCOUNT PRICE: \$2,920.66
Regular Price: \$3,796.86



ORDER FORM, HEADER FORM, AND ADVANCED PAYMENT MUST BE RECEIVED BY DEADLINE DATE.

Packages Include:

- Wall Structure: White PVC side and back walls with silver metal frame (Contact your Freeman Sales Representative regarding graphic wall and shelving upgrade options)
- Graphic Header: Including your company name, booth number, and neighborhood icon (Company name will be printed from directory listing.)
- Carpet Provided by JCK Show Management (No Substitutions)
- First Night Cleaning
- Power for Showcases: Provided by JCK Show Management, 1000 Watts for 80 & 100 Sq. Ft. & 2000 Watts for 200 Sq. Ft.
- Drayage and Labor for installation and removal of structure included

Please Note: The required chrome showcases for the standard booth are not included in this package and will need to be ordered through American Fixture. *State Sales Tax of 8.375% will be added

**For Referral to a Sales Representative, please email:
JCKexhibits@freeman.com**

Standard Exhibitor Booth Package

2022

JCK | LAS VEGAS

The location of your booth is in a neighborhood that requires a booth display that meets the new visual branding guidelines set forth for the show (review full JCK Visual Branding Guidelines on other attachment in this mailing). You can make the selection of either bringing a custom booth that you own (which must be approved by JCK Show Management by April 1, 2022. Find out more on JCK Visual Branding Guidelines attachment) or you will need to utilize the standard exhibitor booth package for your designated neighborhood shown below.



10'x20'
Corner Left

DISCOUNT PRICE: \$3,245.29
Regular Price: \$4,218.14



10'x20'
Corner Right

DISCOUNT PRICE: \$3,245.29
Regular Price: \$4,218.14



10'x20' Angle
Corner Left

DISCOUNT PRICE: \$3,829.85
Regular Price: \$4,894.99

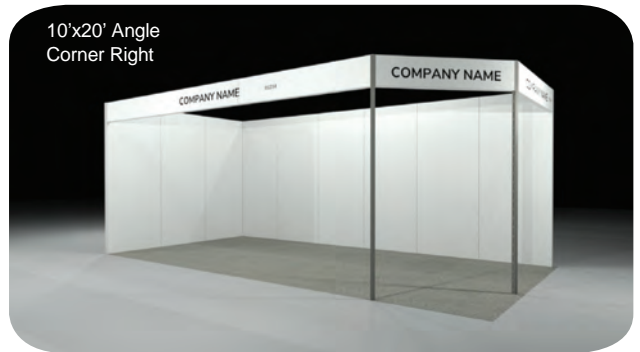

10'x20' Angle
Corner Right

DISCOUNT PRICE: \$3,829.85
Regular Price: \$4,894.99

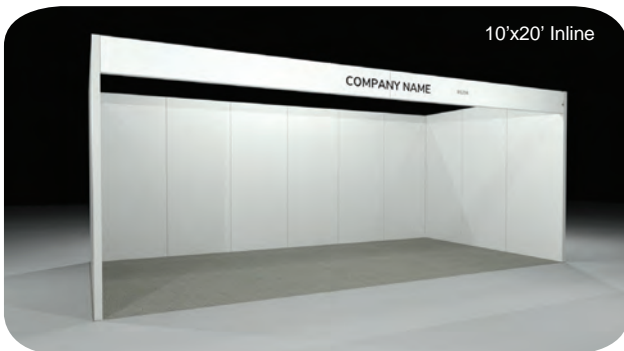

10'x20' Inline

DISCOUNT PRICE: \$3,567.81
Regular Price: \$4,638.25



10'x22' Peninsula

DISCOUNT PRICE: \$3,525.37
Regular Price: \$4,512.01

Packages Include:

- Wall Structure: White PVC side and back walls with silver metal frame (Contact your Freeman Sales Representative regarding graphic wall and shelving upgrade options)
- Graphic Header: Including your company name, booth number, and neighborhood icon (Company name will be printed from directory listing.)
- Carpet Provided by JCK Show Management (No Substitutions)
- First Night Cleaning
- Power for Showcases: Provided by JCK Show Management, 1000 Watts for 80 & 100 Sq. Ft. & 2000 Watts for 200 Sq. Ft.
- Drayage and Labor for installation and removal of structure included

Please Note: The required chrome showcases for the standard booth are not included in this package and will need to be ordered through American Fixture. *State Sales Tax of 8.375% will be added

For Referral to a Sales Representative, please email:
JCKexhibits@freeman.com

NAME OF SHOW: **JCK Las Vegas 2022 / June 10-13, 2022**

COMPANY NAME: _____ BOOTH #: _____

CONTACT NAME: _____ PHONE #: _____

E-MAIL ADDRESS: _____

Take advantage of the Online Price by ordering at www.freeman.com/store by **APRIL 8, 2022**.

STANDARD EXHIBITOR BOOTH PACKAGES

10' x 10' Standard Booth Packages

Part #	Description	Qty	Discount Price Before April 8	Regular Price After April 8	Total
178046	10' x 10' Corner Package - Left		\$2,032.68	\$2,644.82	\$
178067	10' x 10' Corner Package - Right		\$2,032.68	\$2,644.82	\$
178068	10' x 10' Angle Corner Package - Left		\$2,507.97	\$3,081.91	\$
178069	10' x 10' Angle Corner Package - Right		\$2,507.97	\$3,081.91	\$
178075	10' x 10' Inline Package		\$2,245.93	\$2,914.29	\$

10' x 15' Standard Booth Packages

Part #	Description	Qty	Discount Price Before April 8	Regular Price After April 8	Total
178076	10' x 15' Corner Package - Left		\$2,627.85	\$3,416.20	\$
1780125	10' x 15' Corner Package - Right		\$2,627.85	\$3,416.20	\$
1780214	10' x 15' Angle Corner Package - Left		\$3,212.41	\$4,176.13	\$
1780254	10' x 15' Angle Corner Package - Right		\$3,212.41	\$4,176.13	\$
1780406	10' x 15' Inline Package		\$2,920.66	\$3,796.86	\$

10' x 20' Standard Booth Packages

Part #	Description	Qty	Discount Price Before April 8	Regular Price After April 8	Total
1780408	10' x 20' Corner Package - Left		\$3,245.29	\$4,218.14	\$
1780409	10' x 20' Corner Package - Right		\$3,245.29	\$4,218.14	\$
1780411	10' x 20' Angle Corner Package - Left		\$3,829.85	\$4,894.99	\$
1780413	10' x 20' Angle Corner Package - Right		\$3,829.85	\$4,894.99	\$
1780414	10' x 20' Inline Package		\$3,567.81	\$4,638.25	\$
1780740	10' x 22' Peninsula Package		\$3,525.37	\$4,512.01	\$

TOTAL COST

Total Cost = \$ _____
 Applicable taxes will be applied to your order and invoiced accordingly based on specific venue jurisdiction but may also be based on the jurisdiction of where services are performed or your headquarters.

NAME OF SHOW: **JCK Las Vegas 2022 / June 10-13, 2022**

COMPANY NAME: _____ BOOTH #: _____

CONTACT NAME: _____ PHONE #: _____

E-MAIL ADDRESS: _____

Take advantage of the Online Price by ordering at www.freeman.com/store by **MAY 9, 2022**.

LIGHTING OPTIONS

**** PLEASE NOTE: All labor to install the lighting packages is provided by Venetian Expo - SES. ****

Prices for lighting options include installation, maintenance, power, extension cord, and removal. No additional power is needed for lights ordered below. Exhibitor will need to order additional power from SES for any additional power requirements.

Part #	Description	Qty	Discount Price	Regular Price	Total
TRACK LIGHTS					
Option 1 (recommended for lighting any jewelry)					
178031	A: One (1) 4' Track with Two (2) MR16 White Star Fixtures (100 watts)		\$352.40	\$528.60	\$
178032	B: One (1) 4' Track with Three (3) MR16 White Star Fixtures (150 watts)		\$450.80	\$676.20	\$
178033	C: One (1) 4' Track with Four (4) MR16 White Star Fixtures (200 watts)		\$584.20	\$876.30	\$
Option 2 (recommended for lighting diamonds)					
178034	A. One (1) 4' Track with Two (2) LED Fixtures (100 watts)		\$421.20	\$631.80	\$
178035	B. One (1) 4' Track with Three (3) LED Fixtures (150 watts)		\$631.10	\$946.65	\$
178036	C. One (1) 4' Track with Four (4) LED Fixtures (200 watts)		\$704.25	\$1,056.40	\$
Option 3 (recommended for lighting diamonds)					
178037	A. One (1) 4' Track with Two (2) Metal Halide Fixtures (140 watts)		\$483.55	\$725.35	\$
178040	B. One (1) 4' Track with Three (3) Metal Halide Fixtures (210 watts)		\$642.00	\$963.00	\$
172512	Stem Light (recommended for lighting graphics/booth) 100 Watt Halogen		\$171.55	\$257.35	\$



MR 16 (Kelvin Rating of 6500)



LED (Kelvin Rating of 6000)



Metal Halide (Kelvin Rating of 3000)



Stem Light
(100 Watt Halogen)

All lighting options for hardwall booths will be installed behind headers or on wall structure. Please indicate placement of lights on the grid below. Any placement not on perimeter walls will require additional overhead supports and additional charges for the supports will apply. Please indicate placement of fixtures on the diagram below using the appropriate symbol. Attach pictures or drawing of your booth if available.

O = MR16

X = Metal Halide

■ = LED

▲ = Arm Light

TOTAL COST

Total Cost = \$ _____

Applicable taxes will be applied to your order and invoiced accordingly based on specific venue jurisdiction but may also be based on the jurisdiction of where services are performed or your headquarters.

SEEING IS BELIEVING

Quality graphics contribute significantly to the impact of your exhibit. With state-of-the-art design and printing capabilities, Freeman brings your banners, signage, and exhibit graphics to life in a larger-than-life way. Our graphics products redefine "high definition," which means your brand has never been seen like this before.

- Photo-quality / high-resolution printing on a variety of rigid and rolled material including honeycomb, foam, Polyfoam, PVC, acrylic, fabric, vinyl and mesh materials
- Grand Format printers provide high-resolution digital printing of single and double-sided banners in virtually any size
- Electronic file transfer, in-house printing, and company-wide procedure standardization allow us to control quality, cost and scheduling on a nationwide basis
- Extensive resources ensure that last minute repairs and replacements are handled efficiently as needed, no matter where your event may be located



Call customer service at the number listed on the Quick Facts. For fast, easy ordering, go to freeman.com

CREATING VISUAL EXCITEMENT

Quality graphics contribute significantly to the impact of your exhibit. Vivid colors and sharp images attract attention, build traffic, and communicate messages more effectively. Freeman has invested in the latest printing technology and has the skills to provide you with the finest high-resolution digital graphic reproduction available.

STATE-OF-THE-ART CAPABILITIES

Freeman can provide four-color, photo-quality, high-resolution digital printing in virtually any size for banners, signage, exhibit graphics, and more. Each Freeman location has stand-alone printing capabilities, along with two additional graphic locations for additional support and for special requirements.

SUPERIOR QUALITY CONTROL

Electronic file transfer, in-house printing, and company-wide standardization of procedures allow us to control quality, cost and scheduling for our customers on a nationwide basis. Last minute repairs and replacements are handled efficiently through our nationwide resources.

DEPTH OF RESOURCES

- 5M UV roll printers provide grand format, four-color, high-resolution digital printing of single and double-sided banners up to 16' wide and virtually any size with seams.
- 3M Dye Sublimation printers provide 10' fabric graphics that work perfectly in our SmartWall panel system.
- UV flatbeds print directly to a variety of ridged materials and offer a 100% recyclable graphic when using a cardboard substrate.
- Freeman offers 100% recyclable substrates that can save you money and the environment.
- Large format Eco-Solvent printers produce high quality graphics for wall, carpet and window applications.
- 3M high speed digital cutters allow for precise cutting of multiple panel applications and also custom router graphic panels.
- Computer-aided graphic design & layout available for your assistance.

REPRODUCTION AND INSTALLATION

- Suspended banners
- Accent graphic photo panels
- Large format signage and banners
- Logo reproduction
- Backlit displays and murals
- Four-color carpet image printing



NAME OF SHOW: **JCK Las Vegas 2022 / June 10-13, 2022**

COMPANY NAME:

BOOTH #:

CONTACT NAME :

PHONE #:

E-MAIL ADDRESS :

Take advantage of the Discount Price by ordering at www.freeman.com/store by **MAY 09, 2022**.

GRAPHICS

To order your graphics, complete this order form and attach your sign copy or electronic file. Please see artwork guidelines for electronic files on page 2 of this form.

DIGITAL GRAPHICS

Freeman has the capabilities to provide you with the finest digital graphic reproduction available. Capabilities include four-color, photo-quality, high-resolution digital printing virtually any size for banners, signage, exhibit graphics and more.

_____ L X _____ W = _____ sqft
 sqft \$ 18.60 per sqft discount price
 x or = \$ _____
 \$ 27.90 per sqft standard price

- Minimum order per graphic 9 sqft (1296 sqin)
- Double sqft for double-sided graphics
- Round sqft to next whole increment
- File conversion, retouching, cloning or color correcting may incur additional labor charges. (See reverse side for graphic guidelines.)

LARGE DIGITAL GRAPHICS

Please call an Exhibitor Sales Specialist for price quotes on graphics over 80 sqft.

File Information:

Electronic File Name _____

Application _____

PMS Colors _____

Backing Material:

- | | |
|---|--|
| <input type="checkbox"/> Freeman Foam (Foamcore) | <input type="checkbox"/> Masonite |
| <input type="checkbox"/> Freeman PVC (PVC) | <input type="checkbox"/> Plexi |
| <input type="checkbox"/> Freeman HD Foam (Gatorfoam) | <input type="checkbox"/> Freeman Honeycomb (Eco-Board) |
| <input type="checkbox"/> Freeman Polyfoam (Ultra Board) | <input type="checkbox"/> Other |

The product offered has recycled content or has eco-friendly attributes and is 100% recyclable according to the manufacturer's specifications.

Vertical Horizontal Use Your Judgment For Sign Layout

Special Instructions _____

STANDARD SIZES

CHOOSE YOUR SIZE:

QTY.	Discount Price	Standard Price	TOTAL
7" x 11" _____	78.45	117.70 =	_____
7" x 22" _____	80.50	120.75 =	_____
7" x 44" _____	84.15	126.25 =	_____
9" x 44" _____	87.70	131.55 =	_____
11" x 14" _____	95.70	143.55 =	_____
14" x 22" _____	99.60	149.40 =	_____
14" x 44" _____	118.50	177.75 =	_____
22" x 28" _____	123.50	185.25 =	_____
28" x 44" _____	150.35	225.55 =	_____
20" x 60" _____	245.55	368.35 =	_____

(white only)

Note: File conversion, retouching, cloning or color may incur additional labor charges. (See reverse side for graphic guidelines.)

INDICATE YOUR SIGN COPY HERE:

* Please feel free to attach additional sign copy on separate page.

Vertical Horizontal Use Your Judgment For Sign Layout

Background Color: _____

Lettering Color: _____

TOTAL COST

Total Cost = \$ _____

Applicable taxes will be applied to your order and invoiced accordingly based on specific venue jurisdiction but may also be based on the jurisdiction of where services are performed or your headquarters.

CUSTOMER GUIDELINES FOR SUBMITTING GRAPHICS ARTWORK

Our goal is to provide you with the best possible quality graphics for your event or exhibit. You can help us in that effort by providing digital art files using the following guidelines. If you are sending us completed, print-ready files, please pass the following information on to your graphics designer or art department. Artwork must be submitted in the proper resolution and/or file size to produce quality images. Please provide proper color matching information and proofs to ensure accurate color reproduction.

PLEASE PROVIDE THE FOLLOWING WHEN SUBMITTING ART

RASTER ART (photos, logos containing any continuous tone images):

- Art submitted at 1:1 (100%), resolution should be no less than 60 dpi (100 dpi preferred)
- Art submitted at 2:1 (50%), resolution should be no less than 120 dpi (200 dpi preferred)
- Art submitted at 4:1 (25%), resolution should be no less than 240 dpi (400 dpi preferred)

VECTOR ART:

- Logos should be vector and have outlined fonts (if provided as bitmap, please use high-res images)

FONTS and LINKS

- Supply all fonts used in your design (zip Mac fonts). If unsure how to collect fonts, convert them to outlines
- Supply all links used in your document. Use packaging feature if available. If unsure how to collect links, embed them in the file when saving.

COLOR

- If PMS color matching is required, please use original Pantone + Solid Coated swatches in your artwork. Modifying Pantone names will result in printing default color (CMYK)
- CMYK artwork will be produced "As Is". Our color output is balanced and vibrant.
- Convert RGB art to CMYK if possible.
- If you are sending Certified Color Proofs (Gracol, Swop, Fogra), please provide ICC file information used to print your samples. Best option would be to include ICC chart on your prints.

ARTWORK IN THE STRUCTURE

- Please note that any panels going in the metal frame will hide 1/4" of your art all the way around. If you have a continuous wall where individual panels are divided by metal, use 1.25" spacing in between each panel to account for gaps and the natural flow of the graphics.

ACCEPTABLE FILE SOFTWARE

We are capable of working with both PC and MAC based software, and can accept art created with the ADOBE Creative Suite - Illustrator, InDesign, and Photoshop

Always provide the following:

- Native files with fonts and links (zipped)
- High-res PDF-X/4 exports of the files

ACCEPTABLE FILE TYPES and SUPPORT FILES

NATIVE FILES:

- AI CLOUD (CC) file with Packaged supporting links and fonts. You may keep images linked but Packaging feature must be used.
- AI (CS6, CS5, CS4...) file with embedded links and outlined fonts
- EPS file with embedded links and outlined fonts
- INDD file with Packaged supporting links and fonts

PRINT FILES:

- High-res PDF-X/4 (preferred)
- AI with PDF content (choose this option when saving file)
- EPS files with embedded links and outlined fonts

RASTER OR BITMAP ART:

- Photoshop EPS (preferred, use 8-bit preview, Max, Quality JPG compression)
- PSD (make sure font layers are rasterized)
- TIFF, JPG (quality 8 and higher)

Mac users: Use Zip or Stuffit programs when submitting fonts other than OTF (Open Type Fonts)

WAYS TO SEND ARTWORK

- When placing an order online, your order confirmation will include a link to our secure file sharing library so you may upload your graphic files. If your order is faxed in, or if you are working directly with a Freeman team member, a link will be emailed to you when your order is processed.

LET US DO THE HEAVY LIFTING

Freeman specialists are ready to assist you with all of your exhibit requests, from beginning to end. And when it comes to installing and dismantling exhibits, we make no exceptions. Whether it's shipping and storage, emergency on-site repairs, basic installation and dismantling or support service coordination, including electrical, furnishings and more, Freeman has the resources and capabilities to ensure the most successful show experience possible.



Call customer service at the number listed on the Quick Facts. For fast, easy ordering, go to www.freeman.com

Freeman installation & dismantling experts work closely with you to coordinate every phase of your trade show participation, including:

- Pre-planning and budget consultation
- Skilled labor coupled with support services coordination - electrical, furnishings, floral, transportation, and audio visual
- On-site supervisors with dedicated floor managers
- Full, in-house carpentry for emergency repairs and refurbishing
- Post-show evaluations focused on incremental improvement to meet rapidly changing market conditions based upon customer feedback
- Post-show evaluations that help identify small changes that make big impacts

ON-SITE SUPERVISION

You may wish to supervise labor on your own, but if you need assistance, Freeman installation & dismantling experts will get the job done as an extension of your team.

If You Use Freeman Staff

Exhibits can be set up prior to your arrival under the direction of Freeman I&D supervisors.

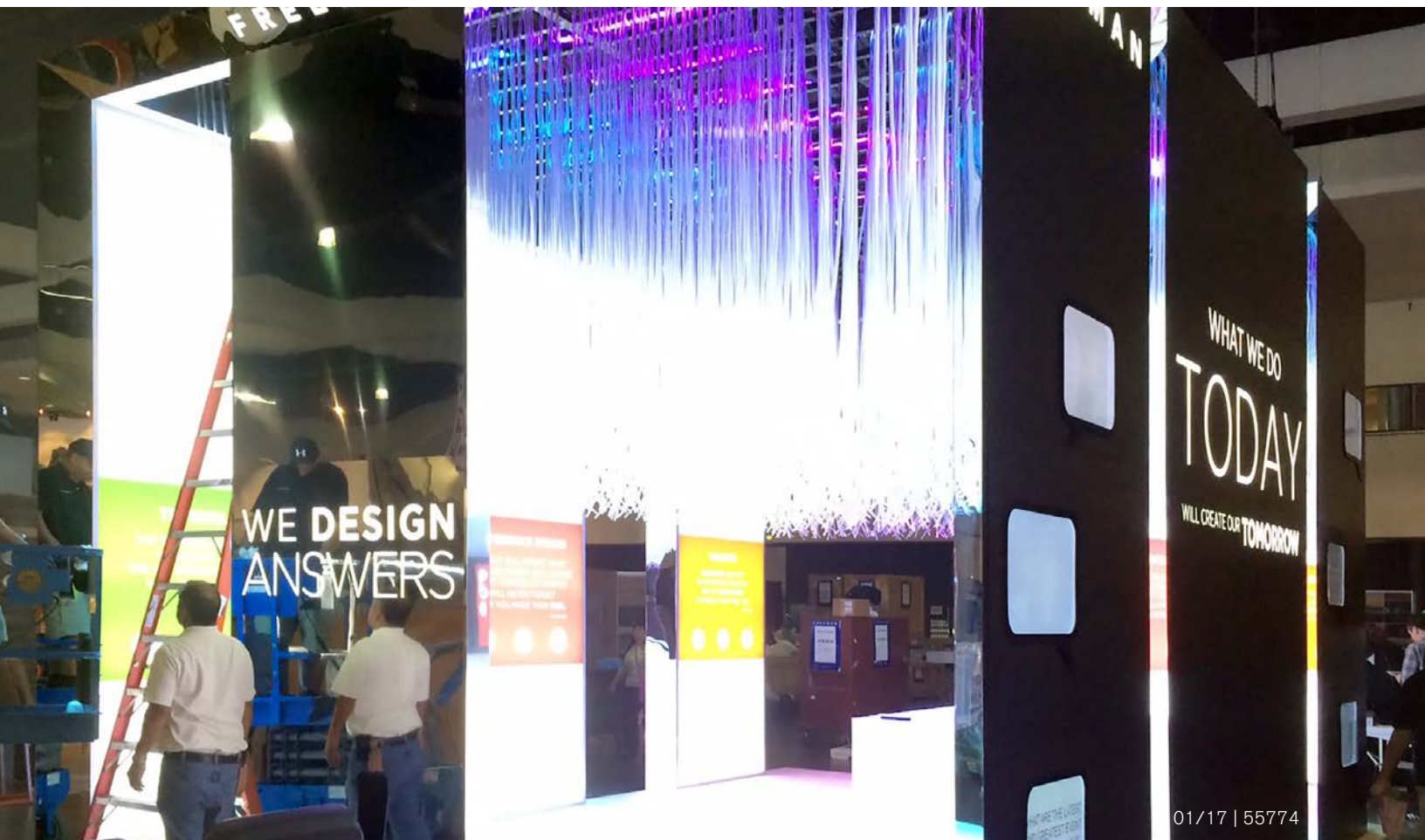

NAME OF SHOW: **JCK Las Vegas 2022 / June 10-13, 2022**

COMPANY NAME: _____ BOOTH #: _____

CONTACT NAME: _____ PHONE #: _____

E-MAIL ADDRESS: _____

For fast, easy ordering, go to www.freeman.com/store.

INSTALLATION & DISMANTLE LABOR

Description	Price Per Hour
Straight Time: 8:00 AM to 5:00 PM Monday through Friday.....	\$105.25
Overtime: 5:00 PM to 8:00 AM Monday through Friday	\$170.25
All day Saturday, Sunday and recognized holidays	

- Price is per person/per hour.
- Start time guaranteed only at start of working day.
- One hour minimum per person - labor thereafter is charged in half (1/2) hour increments.
- When scheduling dismantle labor, be sure to allow sufficient time for empty containers to be returned to your booth.
- Freeman supervised jobs will be completed at our discretion prior to show opening and before the hall must be cleared. **Please include setup plan/photo, special instructions & inbound shipping information with this order.**

INSTALLATION LABOR

Freeman Supervised Labor - Please complete the reverse side of this form.

- Installation of your exhibit will be completed at our discretion prior to show opening.
- The charge for this service is 30% of the total installation labor bill, with a minimum of \$45.00.

Emergency contact: _____ Phone Number: _____

Exhibitor Supervised Labor (Supervisor must check in at the Freeman Service Center to pick up labor)

Supervisor will be: _____ Phone Number: _____

Date	Start Time	No. of People	Approx. Hrs. per Person	Total Hrs.	Hourly Rate	Estimated Total Cost
_____	_____	x	_____	=	_____ x _____	= \$ _____
_____	_____	x	_____	=	_____ x _____	= \$ _____
Freeman Supervision (30%/\$45.00) = \$						_____
Total Installation = \$						_____

DISMANTLE LABOR

Freeman Supervised Labor - Please complete the reverse side of this form.

- Freeman is not responsible for product or literature that is not properly packed and labeled by exhibitor.
- The charge for this service is 30% of the total dismantle labor bill, with a minimum of \$45.00.

Emergency contact: _____ Phone Number: _____

Exhibitor Supervised Labor (Supervisor must check in at the Freeman Service Center to pick up labor)

Supervisor will be: _____ Phone Number: _____

Date	Start Time	No. of People	Approx. Hrs. per Person	Total Hrs.	Hourly Rate	Estimated Total Cost
_____	_____	x	_____	=	_____ x _____	= \$ _____
_____	_____	x	_____	=	_____ x _____	= \$ _____
Freeman Supervision (30%/\$45.00) = \$						_____
Total Dismantle = \$						_____

installation & dismantle labor

NAME OF SHOW: **JCK Las Vegas 2022 / June 10-13, 2022**

COMPANY NAME: _____

BOOTH #: _____

CONTACT NAME: _____

PHONE #: _____

E-MAIL ADDRESS: _____

FREEMAN SUPERVISED LABOR

IN ORDER TO BETTER SERVE YOU - Please complete the following information if your display is to be set-up and/or dismantled by Freeman I&D and you will not be present to supervise the installation and/or dismantle.

INBOUND SHIPPING & SET-UP INFORMATION

Freight will be shipped to: Warehouse _____ Show Site _____ Date Shipped _____

Total No. of Pieces: Crates _____ Cartons _____ Fiber Cases _____

Setup Plan/Photo: Attached _____ To Be Sent With Exhibit _____ In Crate No. _____

Carpet: With Exhibit _____ Rented From Freeman _____ Color _____ Size _____

Electrical Placement: Drawing Attached _____ Drawing With Exhibit _____ Electrical Under Carpet _____

Comments: _____

Graphics: With Exhibit _____ Shipped Separately _____

Comments: _____

Special Tools/Hardware Required: _____

OUTBOUND SHIPPING INFORMATION

SHIP TO: _____

Select a Carrier:

Freeman Exhibit Transportation:
No need to schedule your outbound shipment.
Charges will appear on your Freeman invoice.
Freeman will make arrangements for all
Freeman Exhibit Transportation shipments.

Other Carrier:
Carrier Name: _____
Carrier Phone: _____
Arrangements for pick-up by other carriers is the responsibility of the
exhibitor.

Select Level of Service:

- 1 Day: Delivery next business day
- 2 Day: Delivery by 5:00 PM second business day
- Deferred: Delivery within 3-5 business days
- Standard Ground
- Specialized: Pad wrapped, uncrated or truckload

Freight Charges:

Same as ship to
Bill To: _____

Select Shipment Options (if applicable)

- Have loading dock
- Inside delivery
- Pad wrap required
- Do not stack
- Lift gate required
- Air ride required
- Residential

In the event your selected carrier fails to show on final move-out day, Freeman reserves the right to re-route your freight onto another carrier.

PLEASE NOTE: Freeman is not responsible for product or literature that is not properly packed and labeled by the exhibitor.

installation & dismantle labor



(888) 508-5054
 Fax: (469) 621-5604



Place your order online at
www.freeman.com/store

Submit order forms [here](#).

NAME OF SHOW: **JCK Las Vegas 2022 / June 10-13, 2022**

COMPANY NAME: _____ BOOTH #: _____

CONTACT NAME: _____ PHONE #: _____

E-MAIL ADDRESS: _____

For fast, easy ordering, go to www.freeman.com/store.

FORKLIFT & RIGGING LABOR

Straight Time: 8:00 AM to 5:00 PM Monday through Friday

Overtime: 5:00 PM to 8:00 AM Monday through Friday and all day Saturday, Sunday and recognized holidays

- Start time guaranteed only at start of working day
- One hour minimum - labor thereafter is charged in half (1/2) hour increments
- Supervisor must check in at the Freeman Service Center to pickup labor
- When scheduling dismantle labor, be sure to allow sufficient time for empty containers to be returned to your booth

Part #	Description	Price Per Hour
FORKLIFT LABOR		
304050	Forklift w/operator - up to 5,000 lbs - ST.....	\$220.50
304051	Forklift w/operator - up to 5,000 lbs - OT.....	\$343.75
3040100	Forklift w/operator - up to 10,000 lbs - ST.....	\$236.75
3040101	Forklift w/operator - up to 10,000 lbs - OT.....	\$356.25
3040150	Forklift w/operator - up to 15,000 lbs - ST.....	\$316.75
3040151	Forklift w/operator - up to 15,000 lbs - OT.....	\$398.75
304040	Forklift w/operator - 4-Stage - ST.....	\$280.75
304041	Forklift w/operator - 4-Stage - OT.....	\$391.50
RIGGING LABOR		
3020100	Rigger - ST.....	\$106.25
3020101	Rigger - OT.....	\$171.25
EQUIPMENT		
3090600	Forklift Cage.....	\$42.00
3090700	Forklift Boom.....	\$42.00
3090800	Pallet Jack.....	\$42.00

INSTALLATION

Part #	Description	Start Date	Start Time	No. Equip/ People	Approx. Hrs. per Person	Total Hours	Hourly Rate	Estimated Total Cost

Describe work to be done: _____ **Total Installation** \$ _____

DISMANTLE

Part #	Description	Start Date	Start Time	No. Equip/ People	Approx. Hrs. per Person	Total Hours	Hourly Rate	Estimated Total Cost

Describe work to be done: _____ **Total Dismantle** \$ _____

Applicable taxes will be applied to your order and invoiced accordingly based on specific venue jurisdiction but may also be based on the jurisdiction of where services are performed or your headquarters.
 (508986)

forklift & rigging labor

EVENT TECHNOLOGIES THAT ENHANCE EXPERIENCES

.....

When it comes to promoting your exhibit, let our technology do the talking. Freeman offers the most extensive inventory of audio visual products available, ensuring a custom experience that excites the senses and breathes life into your booth, giving it the appeal to draw in customers.

- Our audio visual experts can assist with a wide range of technology solutions for custom rental exhibit programs that fit any size or budget
- Full service resources include digital services, flat screen technology, intelligent LED light displays, seamless plasma and LED panel solutions and immersive audio experiences
- Schedule deliveries with advance confirmation to meet your timeline specifications
- Preshow consultation, installation, operation, and comprehensive invoice services provide a streamlined solution for all your rental needs



Call customer service at the number listed on the Quick Facts. For fast, easy ordering, go to www.freeman.com

Freeman Event Technology offers the widest array of audio visual products in our expansive network throughout North America. Our exhibit specialists can assist with a full range of audio visual equipment for portable, modular and custom rental exhibit programs to fit any size or budget. Full service resources include digital services, lighting, flat screen technology, computer equipment and LED displays.

Freeman Event Technology establishes the right combination of equipment and services that will command attention while communicating your company's message. Whatever your needs, our dedicated service and technical on-site support teams will be available to ensure your exhibit program's success. With more than 3,500 full-time audio visual experts and \$100 million in inventory, you can always count on Freeman Event Technology to recommend the perfect combination of audio visual solutions to enhance your company's brand.

- PRESHOW CONSULTATION REGARDING EQUIPMENT SPECIFICATIONS AND BUDGETING
- ONE SEAMLESS SOURCE FOR ALL YOUR TECHNOLOGY SOLUTIONS, INCLUDING A COMPLETE RANGE OF AUDIO VISUAL AND COMPUTER EQUIPMENT AND INSTALLATION SERVICES
- INTELLIGENT LIGHTING DESIGN, INSTALLATION AND OPERATION
- SCHEDULED DELIVERIES WITH ADVANCE CONFIRMATION TO MEET YOUR TIMELINES
- AUDIO VISUAL EXPERTS THAT OFFER PERSONALIZED, DEDICATED SERVICE



NAME OF SHOW: **JCK Las Vegas 2022 / June 10-13, 2022**

COMPANY NAME: _____ BOOTH #: _____

CONTACT NAME: _____ PHONE #: _____

E-MAIL ADDRESS: _____

Take advantage of the Online Price by ordering at www.freeman.com/store by MAY 9, 2022.

AUDIO VISUAL

- Orders received after the deadline date or without payment will be charged the Standard Price.
- Electrical labor and internet services are NOT included in equipment pricing.
- Pricing is for the length of the event and includes product delivery.
- Please call for meeting room support or items that are not listed.

FLAT SCREEN PACKAGES

Qty	Description	Discount Price	Standard Price	Total
• All screens are 1080p with dual post stand				
_____	32" Flat Screen.....	\$740.00	\$962.00	\$ _____
_____	42" Flat Screen.....	\$900.00	\$1,170.00	\$ _____
_____	55" Flat Screen.....	\$1,510.00	\$1,963.00	\$ _____
_____	70" Flat Screen.....	\$2,145.00	\$2,788.50	\$ _____
_____	90" Flat Screen (includes hydraulic stand).....	\$3,810.00	\$4,953.00	\$ _____
• All screens are 1080p with dual post stand and external USB media player.				
_____	32" Flat Screen.....	\$870.00	\$1,131.00	\$ _____
_____	42" Flat Screen.....	\$1,025.00	\$1,332.50	\$ _____
_____	55" Flat Screen.....	\$1,635.00	\$2,125.50	\$ _____
_____	70" Flat Screen.....	\$2,270.00	\$2,951.00	\$ _____
_____	90" Flat Screen (includes hydraulic stand).....	\$3,935.00	\$5,115.50	\$ _____
• All screens are 1080p with dual post stand and laptop.				
_____	32" Flat Screen.....	\$1,085.00	\$1,410.50	\$ _____
_____	42" Flat Screen.....	\$1,245.00	\$1,618.50	\$ _____
_____	55" Flat Screen.....	\$1,850.00	\$2,405.00	\$ _____
_____	70" Flat Screen.....	\$2,485.00	\$3,230.50	\$ _____
_____	90" Flat Screen (includes hydraulic stand).....	\$4,155.00	\$5,401.50	\$ _____

TOUCHSCREEN PACKAGES

Qty	Description	Discount Price	Standard Price	Total
• All packages include dual post stand and laptop.				
_____	32" Touchscreen.....	\$1,430.00	\$1,859.00	\$ _____
_____	46" Touchscreen.....	\$1,850.00	\$2,405.00	\$ _____
_____	55" Touchscreen.....	\$2,275.00	\$2,957.50	\$ _____
• All packages include dual post stand.				
_____	32" Touchscreen.....	\$1,085.00	\$1,410.50	\$ _____
_____	46" Touchscreen.....	\$1,510.00	\$1,963.00	\$ _____
_____	55" Touchscreen.....	\$1,930.00	\$2,509.00	\$ _____

NAME OF SHOW: **JCK Las Vegas 2022 / June 10-13, 2022**

COMPANY NAME: _____ BOOTH #: _____

CONTACT NAME: _____ PHONE #: _____

E-MAIL ADDRESS: _____

FLAT SCREEN DISPLAYS

Qty	Description	Discount Price	Standard Price	Total
-----	-------------	----------------	----------------	-------

• Please call for pricing on Flat Screens 98" and larger, 4K UHD, & LED Video Wall options.

_____	24" Monitor - 1080p, (no sound).....	\$305.00	\$396.50	\$ _____
	<input type="checkbox"/> Table Top <input type="checkbox"/> Wall Mounted			
_____	32" Flat Screen - 1080p, with Internal Speakers.....	\$505.00	\$656.50	\$ _____
	<input type="checkbox"/> Table Top <input type="checkbox"/> Wall Mounted			
_____	42" Flat Screen - 1080p, with Internal Speakers.....	\$660.00	\$858.00	\$ _____
	<input type="checkbox"/> Table Top <input type="checkbox"/> Wall Mounted			
_____	55" Flat Screen - 1080p, with Internal Speakers.....	\$1,270.00	\$1,651.00	\$ _____
	<input type="checkbox"/> Table Top <input type="checkbox"/> Wall Mounted			
_____	70" Flat Screen - 1080p, with Internal Speakers.....	\$1,905.00	\$2,476.50	\$ _____
	<input type="checkbox"/> Table Top <input type="checkbox"/> Wall Mounted			

TOUCHSCREEN DISPLAYS

Qty	Description	Discount Price	Standard Price	Total
-----	-------------	----------------	----------------	-------

• Touchscreens will require a PC/laptop to operate. Not compatible with Mac. Please call for larger sizes.

_____	32" Touchscreen with Internal Speakers.....	\$845.00	\$1,098.50	\$ _____
	<input type="checkbox"/> Table Top <input type="checkbox"/> Wall Mounted			
_____	46" Touchscreen with Internal Speakers.....	\$1,270.00	\$1,651.00	\$ _____
	<input type="checkbox"/> Table Top <input type="checkbox"/> Wall Mounted			
_____	55" Touchscreen with Internal Speakers.....	\$1,695.00	\$2,203.50	\$ _____
	<input type="checkbox"/> Table Top <input type="checkbox"/> Wall Mounted			

VIDEO PLAYERS

Qty	Description	Discount Price	Standard Price	Total
-----	-------------	----------------	----------------	-------

_____	USB Media Player.....	\$125.00	\$162.50	\$ _____
_____	Blu-ray Player.....	\$160.00	\$208.00	\$ _____
	HDCP Compliant, compatible with Blu-ray and DVD			

COMPUTERS & ACCESSORIES

Qty	Description	Discount Price	Standard Price	Total
-----	-------------	----------------	----------------	-------

_____	Desktop Computer with 24" Monitor.....	\$290.00	\$377.00	\$ _____
	includes wired keyboard and mouse			
_____	Laptop Computer	\$345.00	\$448.50	\$ _____
_____	Wireless Keyboard with Mouse.....	\$105.00	\$136.50	\$ _____
_____	Apple 21.5" iMac (includes wired keyboard and mouse)	\$315.00	\$409.50	\$ _____
_____	Apple 15" MacBook Pro	\$475.00	\$617.50	\$ _____
_____	iPad Stands - White	\$160.00	\$208.00	\$ _____
	<input type="checkbox"/> Table Stand <input type="checkbox"/> Floor Stand			

audio visual

NAME OF SHOW: **JCK Las Vegas 2022 / June 10-13, 2022**

COMPANY NAME: _____ BOOTH #: _____

CONTACT NAME: _____ PHONE #: _____

E-MAIL ADDRESS: _____

AUDIO EQUIPMENT

Qty	Description	Discount Price	Standard Price	Total
_____	Sound Bar - 2.1 Full Range, with Built-in Subwoofer	\$80.00	\$104.00	\$ _____
	Compatible with 42" monitors and above			
_____	Small High Performance PA System	\$630.00	\$819.00	\$ _____
	Includes wireless microphone, 2 speakers, 1 Mixer/Amp, computer interface box			
	<input type="checkbox"/> Handheld <input type="checkbox"/> Headset (for best sound quality, choose Headset)			

EXHIBIT LIGHTING PACKAGES

Qty	Description	Discount Price	Standard Price	Total
_____	Six (6) 12" LED Lighting Fixtures	\$795.00	\$1033.50	\$ _____
	<input type="checkbox"/> Amber <input type="checkbox"/> Blue <input type="checkbox"/> Green <input type="checkbox"/> Red			
_____	Twelve (12) 12" LED Lighting Fixtures	\$1,585.00	\$2,060.50	\$ _____
	<input type="checkbox"/> Amber <input type="checkbox"/> Blue <input type="checkbox"/> Green <input type="checkbox"/> Red			

DELIVERY INFORMATION

Thank you for using Freeman to meet your Audio Visual equipment needs. You can be confident that our Audio Visual Experts will be on-site to deliver, install, and provide any necessary technical support. Your booth must have all supporting elements installed before we can deliver your equipment. All Audio Visual equipment will be installed no later than the last day of move in.

If you find any expected equipment missing from your booth, please visit the Exhibitor Service Center.

On-Site Contact Person: _____ Cell Phone: _____

If You Have a Special Delivery Request, Please Note it Here: _____

PAYMENT INFORMATION

A Freeman representative will provide a secured payment link after receiving your order. A credit card is required to secure all orders, even when paying by ACH, check or wire transfer. Cash payments will no longer be accepted while on show-site. Full payment including applicable tax must be made in advance, in US funds. Equipment may not be provided and installed if payment has not been received prior to show move-in.

PURCHASE TERMS

Freeman's Terms & Conditions apply to all orders submitted to Freeman for any goods or services, and may be amended without notice. To review the current Terms & Conditions, [click here](#).

ELECTRICAL SERVICE

Please contact the electrical contractor to place your electrical order.

READY FOR DELIVERY ONSITE

For delivery of your audio visual equipment, please notify the Freeman Service Center as well as the electrical contractor electricians. We will work with the electrical contractor electricians to deliver and set your equipment order.

TOTAL COST
Total Cost = \$ _____
Applicable taxes will be applied to your order and invoiced accordingly based on specific venue jurisdiction but may also be based on the jurisdiction of where services are performed or your headquarters.

audio visual



1-800-573-5430

JCK 2022 : JCK 2022 – Event Security

DATE: June 10, 2022 - June 13, 2022

Address The Venetian Expo, Sands Avenue, Las Vegas, NV, USA

Order Online: <https://centurytradeshow.com/event/jck-2022/event-security/>

Passcode: JCK22

Packages (Pre Order by May 20, 2022)

	Pre-Order	On-Site
UNARMED MONITOR	\$29.35	\$36.25
ARMED MONITOR	\$59.25	\$66.00

Package	# of personnel	Start Date	End Date	Total Hours

Additional Open Items

Item Name	Price

Sub Total: _____

Total _____

RULES AND REGULATIONS

- All Booth Monitoring personnel must be provided through Century Security.
- Booth Monitoring personnel will remain on duty until released, exhibitor is responsible for any additional charges.
- There is a minimum of five (5) hours per person per shift.
- Armed monitor must be placed a minimum of 24 hours in advance.
- Booth Monitoring orders placed less than 24 hours in advance are not guaranteed.

ADVANCE PAYMENT MUST BE RECEIVED BY (21 DAYS PRIOR TO THE FIRST SHOW DAY) TO QUALIFY FOR DISCOUNT (INCENTIVE RATES). BASE RATES APPLY TO ALL ORDERS/PAYMENTS RECEIVED AFTER 21 DAY DEADLINES. ALL PAYMENTS MUST BE MADE IN FULL BY CHECK OR MONEY ORDER (PAYABLE IN U.S. FUNDS ON U.S. BANKS). VISA, MASTERCARD OR AMERICAN EXPRESS. NO PURCHASE ORDERS ACCEPTED. IF YOU DO NOT RECEIVE CONFIRMATION ON YOUR ORDER FROM CENTURY SECURITY, WE CANNOT GUARANTEE YOUR COVERAGE. PLEASE CONTACT OUR OFFICE AT 407-226-1168 AT LEAST 7 DAYS PRIOR TO EVENT TO REQUEST CONFIRMATION.

BILLING INFORMATION

Booth #*	Exhibitor Name*		
Contact #*	Fax #	Email*	
Address*			
Street Address			
city	State	zip code	
On-Site Contact Person	Contact #		

Payment in Full Must Be Rendered Before Service is Provided

Remit Payment To

Century Security & Event Staffing, Inc.
6421 Pinecastle Blvd. (Suite 1)
Orlando, FL 32809

Method of Payment*

- Company Check or Money Order
- Credit Card

Credit card detail

Card Number: _____

Month: _____ Year: _____ Security Code: _____

Cardholder Name: _____

Authorized Signature: _____

Date: _____

Century Security is not an insurer. Charges are based solely upon the value of services provided for, and are unrelated to the value of the clients operations property or the property of others. The amounts payable by the client are not sufficient to warrant assuming any risk of damage or loss to property due to Century Security's negligence or failure to perform. Century Security, its agents and representatives, will provide all necessary safeguards and shall assume no liability for life, accident, theft of property, damage to property or any other loss due to factors beyond our control. The client, by signing this agreement, holds Century Security harmless for any and all losses and agrees to have in effect at the time of signing this agreement insurance to cover all product, and personnel damages and any claims arising from engaging in business as an exhibitor. Century Security will send out final invoices within ten (10) days after the close of the event.



JCK 2022 : JCK 2022 – Event Surveillance

DATE: June 10, 2022 - June 13, 2022

Address The Venetian Expo, Sands Avenue, Las Vegas, NV, USA

Order Online: <https://centurytradeshows.com/event/jck-2022/event-surveillance/>

Passcode: JCK22

1-800-573-5430

Century Security, is offering CCTV (Closed Circuit Television) systems to the exhibitors for this event, for use in their booth or meeting room space. These CCTV systems are offered in conjunction with either armed or unarmed security officers for use during the event. The pricing for these systems includes installation/dismantle, the number of digital cameras by package, DVR (Digital Video Recorder), 24 hour real-time digital recording and monitors. Each systems has the capability of writing the video to USB drive, but is only completed if an incident occurs at the booth. We advise you to contact your insurance company prior to completing your order to ensure you have met their requirements. For orders placed in advance of the move in of the show, the CCTV system rented will be set the day prior to the event, at which time the recording will begin, recording will stop when the unit is removed from the booth on the evening the event closes. Additional cameras are also available as rentals, but please keep in mind an additional DVR will be needed for every 8 cameras. Orders placed less than 72 hours in advance are not guaranteed.

CCTV System Packages

CCTV System Packages	Prices Expire On				Quantity
	2022-05-20	2022-05-27	2022-06-03	2022-06-07	
(CCTV) System w/2 Cameras	\$ 1000.00	\$ 1375.00	\$ 1425.00	\$ 1475.00	_____
(CCTV) System w/4 Cameras	\$ 1200.00	\$ 1675.00	\$ 1725.00	\$ 1775.00	_____
(CCTV) System w/8 Cameras	\$ 1600.00	\$ 2275.00	\$ 2325.00	\$ 2375.00	_____
Additional Cameras	\$ 250.00	\$ 300.00	\$ 350.00	\$ 400.00	_____

Add-On Packages

Cameras placed higher than 8ft	125.00	_____
Onsite Camera Placement Change (1 hour Minimum)	150.00	_____
Order Footage (USB Drive)	200.00	_____

All orders must be submitted with a diagram clearly detailing the booth space. Please include furniture placement, display cabinets, tables, safes and your desired camera placement. Please be sure to make us aware of a particular area you would like to capture if needed. Additional fees will apply to camera placement changes onsite. In addition, all exhibitors are to order 24hr electric services through the venue for all camera orders.

Additional Open Items

Item Name	Price
_____	_____
_____	_____

Sub Total: _____

Total _____

BILLING INFORMATION

Booth #*		Exhibitor Name*	
Contact #*	Fax #	Email*	
Address*			
Street Address	City	State	zip code
On-Site Contact Person		Contact #	

Remit Payment To

Century Security & Event Staffing, Inc. 6421 Pinecastle Blvd. (Suite 1) Orlando, FL 32809	Method of Payment* <input type="radio"/> Company Check or Money Order <input type="radio"/> Credit Card	Payment in Full Must be Rendered Before Service is Provided. ALL PAYMENTS ARE TO BE MADE IN FULL BY CHECK, MONEY ORDER (PAYABLE IN U.S. FUNDS ON U.S. BANKS), VISA/MASTERCARD, AMERICAN EXPRESS.
---	---	---

Credit card detail

Card Number: _____	Month: _____	Year: _____	Security Code: _____
Cardholder Name: _____			

Additional Onsite Charges

Cameras placed higher than 8ft	125.00	_____
Onsite Camera Placement Change (1 hour Minimum)	150.00	_____
Order Footage (USB Drive)	200.00	_____
Grand Total		_____

signature _____ Date _____ Method of Payment Cash Credit Card Card on File

Century Security is the exclusive CCTV provider for this event. Century Security is not an insurer. Charges are based solely upon the value of services provided for, and are unrelated to the value of the clients' operations property or the property of others. The amounts payable by the client are not sufficient to warrant assuming any risk of damage or loss to property due to Century Security's negligence or failure to perform. Century Security, its agents and representatives, will provide all necessary safeguards and shall assume no liability for life, accident, theft of property, damage to property or any other loss due to factors beyond our control. The client, by signing this agreement, holds Century Security harmless for any and all losses and agrees to have in effect at the time of signing this agreement insurance to cover all product, and personnel damages and

any claims arising from engaging in business as an exhibitor. If an incident occurs and the client is requesting the footage, the deadline for this is at the close of show. Requests beyond 60 days of close of show, cannot be guaranteed. Receiving footage could take up to 120 days. The expense of the USB drive will be billed to the client. Century Security will send out final invoices and receipts within ten (10) days after the close of the event.

Spring Valley Floral

DECORATING COMPANY INC.
 Mailing Address: 241 S. Little Tor Road
 New City, NY 10956
 TEL: 845 268-7555
 Web Site: www.springvalleyfloral.com
 Email: maryann@springvalleyfloral.com

FLORAL DECORATIONS

JCK | LAS VEGAS

June 10 - 13, 2022
 VENETIAN EXPO
 Halls A, B, C, G

CUSTOM FLORAL SERVICES	Cost Each	Quan.	Total
Fresh Floral Arrangement 12 - 14" High	70.00		
Fresh Floral Arrangement 15 - 18" High	80.00		
Exotic Floral Arrangement 14" High	85.00		
Exotic Floral Arrangement 24" High	99.00		

RENTAL GREEN & FLOWERING PLANTS

Mum Plants — yellow — white — lavender	30.00		
Azaleas	35.00		
Green Table Plant	30.00		
Large Fern	40.00		
3-foot Green Plant	47.00		
4-foot Green Plant	57.00		
5-foot Green Plant	67.00		
6-foot Green Plant	77.00		
8-foot Green Plant	94.00		

ALL PRICES INCLUDE
 INSTALLATION, SERVICING,
 AND REMOVAL AT END OF
 SHOW

SPECIAL SERVICES
 AVAILABLE UPON REQUEST

- GARDEN AREAS
- FOUNTAINS
- HOSPITALITY SUITES
- LUNCHEONS
- BANQUETS

ON SITE ORDERS SUBJECT TO
 AVAILABILITY

___ PLEASE HAVE YOUR
 DESIGNER COME BY TO
 MAKE SUGGESTIONS
 DATE/TIME _____

SUBTOTAL: _____

ADD 8.375% LAS VEGAS SALES TAX: _____

TOTAL: _____

ALL PLANTS INCLUDE
 DECORATIVE
 CONTAINERS

PLEASE CHECK ONE
 ___ WHITE ___ BLACK

PAYMENT POLICY: ALL ORDERS MUST BE PAID IN ADVANCE

Enclose your check or credit card information as indicated below. Make checks payable to: Spring Valley Floral.

Credit Account Number

1	2	3	4	5	6	7	8	9	10	11	12	13	14	15	16
---	---	---	---	---	---	---	---	---	----	----	----	----	----	----	----

Expiration Date MM/YY

		-		
--	--	---	--	--

American Express (15 Digits) Check

MasterCard (16 Digits) Visa (13 or 16 Digits)

Authorized Signature

Name on Card

Security Code

RETURN THIS ORDER WITH PAYMENT TO SPRING VALLEY FLORAL

Company _____ Phone _____

Address _____ FAX _____

City, Zip, State _____ E-mail _____

Party in Charge _____ Onsite Phone _____

Authorized Signature _____ **BOOTH #** _____



International Shipping & U.S. Customs Guidelines

JCK June 10-13, 2022

Venetian Expo, Las Vegas, NV

Official Customs Broker and Freight Forwarder

PIBL - Phoenix International Business Logistics, Inc.

1201 Corbin Street

Elizabeth, NJ 07201

Attention:

Sally Mulkeen

Tel: 908.355.8900

Fax: 908.355.8883

E-Mail: smulkeen@phoenixlogistics.com

Freight originating from cities outside the United States requires special consideration not covered in the handling and shipping section of this manual. The U.S. Customhouse Broker is available to advise the best methods of transportation and proper documentation. Please address all inquiries to the above individual.

CUSTOMS CLEARANCE OPTIONS

PIBL can arrange to clear your merchandise through customs on a temporary or permanent duty paid entry. If you are intending to ship high value merchandise, we suggest you apply for an ATA Carnet in the country of origin. Carnets should only be utilized for high valued merchandise which is intended for re-export from the U.S. in the same condition in which they were imported. Merchandise entered into the U.S. under a Carnet and not exported is subject to U.S. Customs duty, penalties and or fines.

TRANSPORTATION SERVICES

For information regarding export services from your location to Las Vegas, please feel free to contact one of the following PIBL agents or contact us in NJ for the name and phone number of an agent nearest you.

<p style="text-align: center;">UNITED KINGDOM</p> <p style="text-align: center;">GBH Exhibition Forwarding Ltd, 10 Orgreave Drive Handsworth, Sheffield S13 9 NR Contact: Mark Saxton Phone: [44] 1142690641 Fax: [44] 1142693624 E-mail:Mark@gbhforwarding.com</p>	<p style="text-align: center;">Germany</p> <p style="text-align: center;">FairExpress GMBH Grafenheider Strasse 103 33729 Bielefeld/Germany Contact: Christiane Roelfs Phone: [49]52-191144-20 Fax: [49]52-1911-4411 E-mail: christiane.roelfs@fairexpress.de</p>
<p style="text-align: center;">Japan</p> <p style="text-align: center;">Nissin Corporation 5.Sanbancho, Chiyoda-ku, Tokyo, 102-8350, Japan Contact: Exhibition Team Phone: 81-332386500 Fax:]81332386508 E-mail: exhibition@nissin-tw.com</p>	<p style="text-align: center;">AUSTRALIA</p> <p style="text-align: center;">Agility Fairs and Events 32 Sky Road Melbourne Airport VIC 3045, Australia a Contact: Shanade Stronson Phone: 61-3-9-330-3303 / Fax: 61-393-303337 E-Mail: expoeasy@agilitylogistics.com</p>
<p style="text-align: center;">SPAIN</p> <p style="text-align: center;">Internacional Trade Shows S.A. (ITS, S.A) AVDA. Eduard Corbella, 86-88 Barcelona, Spain E-08440 Contact: Mr. Marc Vidal Phone: [34] 932004675 Fax: [34] 932001694 E-mail: marc.vidal@itsfairs.com</p>	<p style="text-align: center;">CANADA</p> <p style="text-align: center;">PIBL - Phoenix Int'l Business Logistics, Inc 1201 Corbin Street Elizabeth, NJ 07201 Contact: Roger Howell Tel: 8908-355-8900 Fax: 908-355-8883 E-Mail: Rhowell@phoenixlogistics.com</p>

MARKING

To ensure timely delivery to your stand, all cases should be marked as follows:

Name of Exhibitor
Name of Show and Exhibition Center
Booth number
Piece #1 /up

DOCUMENTS REQUIRED (Forward to Phoenix NJ)

Original Bills of Lading / Commercial Invoice / U.S. Customs Power of Attorney/Import Freight Information Sheet

OCEAN FREIGHT AND AIRFREIGHT SHIPMENTS

It is imperative that all documents be issued in English only. Documents issued in other languages will be translated at the expense of the exhibitor.

The Commercial invoice must contain the following details:

- Complete name and address of the exhibitor
- Quantity of each description
- Detailed description of merchandise
- Country of origin
- Individual and total price of each description
- Total value of shipment

All commercial invoices should mention that the shipment consists of exhibition goods to be exhibited at the show and whether the goods are for temporary or permanent importation. Temporary and permanent shipments can not be consolidated and shipped under the same bill of lading. Separate bills of ladings and invoices must be issued. All goods intended for sale in the United States are subject to normal customs duty and taxes.

INTERNATIONAL SMALL PACKAGE SHIPMENTS

Small package shipments are defined as shipments less than 50 kgs. Successful customs clearance and delivery of international small package shipments can be a challenge. To reduce delays, additional expenses and possible non delivery of your shipment, we recommend exhibitors utilize our door-to-door delivery services. In conjunction with our overseas agents, our staff arranges the transportation from origin, the customs clearance, and the delivery of your small package shipment to the show at a competitive price. Please contact us to discuss the best method for handling your small package shipment.

CONSIGNEE & NOTIFY PARTIES

Consign & Notify both Air & Ocean Shipments as follows:

Consignee: Name of exhibiting company
JCK 2022 / Booth # ____
C/O Venetian Expo
201 Sands Avenue, Las Vegas, NV 89169

Notify Party: PIBL – Phoenix Intl Business Logistics, Inc.
ATTN: Sally Mulkeen 908-355-8900

All documents such as invoices and packing lists should accompany air shipments and must arrive with the freight.

RETURN TRANSPORTATION OF EXHIBITION GOODS

After the close of the exhibition, please make arrangements with PIBL for the return transportation of your exhibition goods to the country of origin or any other destination of your choice. Quotations may be obtained in advance from PIBL by emailing your requirements to the Phoenix agent listed above.

PAYMENT CONDITIONS

Invoices for services rendered on inbound movements are payable prior to delivery of freight to the exhibition center through our designated agents or directly to PIBL. Phoenix accepts cash, American Express or traveler's checks.

TERMS OF FREIGHT ACCEPTANCE

All freight shipments must be shipped to the U.S. on a prepaid basis.

TERMS AND CONDITIONS OF SERVICE

All business undertaken by PIBL is subject to the terms and conditions of service as recommended by the Freight Forwarders and Brokers Association, Inc. Text available upon request.

TERMS OF DELIVERY/DEADLINES FOR ARRIVAL IN US

In order to assure timely delivery to show site, freight and documents must arrive in the U.S. between 8 - 10 days prior to your move in date. A late surcharge will be applied to all shipments arriving within 5 working days of the show set-up.

US/CANADIAN BORDER CROSSINGS

Canadian exhibitors seeking to export exhibit materials to the U.S. should be advised that U.S. Customs will require an IRS identification number for the entry of these shipments to the U.S. If your organization does not have an IRS number, your U.S. Customs broker has the capability to file and receive a temporary IRS number on your behalf. Failure to provide this number to the U.S. Broker at the border crossing will result in delays. Show Management cannot provide their tax identification number to exhibitors as the importer of record must be the name of the exhibitor or a distributor representing the exhibitor.

Exhibitor's expecting problems with border clearances should contact PIBL at 908-355-8900. For a fee, PIBL is prepared to clear your merchandise at the border or in Las Vegas using their IRS number as the ultimate consignee. Please contact them in advance to discuss document requirements.

RESTRICTIONS ON WOOD PACKING MATERIAL

The United States Department of Agriculture (USDA) Animal and Plant Health Inspection Service (APHIS) has revised its import regulation for wood packaging materials (WPM), 7 CFR § 319. The final rule was effective September 16, 2006 with full enforcement began July 5, 2006.

The regulation restricts the importation of many types of untreated wood articles, including wooden packaging materials such as pallets, crates, boxes, and pieces of wood used to support or brace cargo. The regulations currently refer to these types of wood packaging materials as solid wood packing materials, defined as "wood packing material other than loose wood packing material, used or for use with cargo to prevent damage, including, but not limited to, dunnage, crating, pallets, packing blocks, drums, cases, and skids." Any WPM not meeting the treatment specifications of this rule will be immediately re-exported.

The rule states that regulated wood packaging materials must be marked in a visible location on each article, preferably on at least two opposite sides of the article, with a legible and permanent mark that indicates that the article meets the new requirements. Paper treatment certificates will continue to be accepted until July 5, 2006. Should you have any questions regarding the wood packing material used for your exhibit, please consult your local Phoenix agent, in house freight forwarder, or packing and crating company. Additional information on this subject can be found on the USDA Website: <http://www.aphis.usda.gov/lpa/issues/wpm/wpm.html>

JCK
June 10-13, 2022
Las Vegas

**Oscar & Associates, the official provider of
Photographic, Video & Live Streaming Services**

As the official photo and video provider of this event OA has:

- Access to the show floor before, during and after show hours.
- All access show credentials (no need to secure badges for our team).
 - Been vetted by show management.

**Scan QR Code to access shopping cart to view services,
pricing & place your order.**



Or visit

www.Shop.OscarAndAssociates.com

Book your services by **May 18, 2022 enter code **JCK22**
and receive **10%** off your entire order!**

Standard White Line

STANDARD WHITE FEATURES:



- Fluorescent lighting
- LED lighting available for an additional \$85 per showcase
- Aluminum frame
- Matte white formica exterior
- Solid sides
- Sliding doors with lock (no mirrors)
- Rear storage area with lock in half and quarter vision cases
- Available in 4', 5' and 6' lengths and corner cases
- 38" high and 20" deep
- Showcases are available in full, half and quarter vision
- Corner cases are available in half and quarter vision only

SIZE	QUANTITY			ADVANCED PRICE	PRICE FOR ORDERS RECEIVED AFTER 04/29/2022	SHOW SITE PRICE	TOTAL
	FULL VISION	HALF VISION	QUARTER VISION				
4 FOOT				\$370.00	\$445.00	\$570.00	
5 FOOT				\$370.00	\$445.00	\$570.00	
6 FOOT				\$370.00	\$445.00	\$570.00	
34" CORNER	X			\$390.00	\$465.00	\$590.00	

* MANDATORY ELECTRIC FEE - Add \$25.00 per showcase \$ _____

Add \$85.00 per showcase for LED lighting \$ _____

SUBTOTAL \$ _____

8.375% SALES TAX \$ _____

TOTAL DUE \$ _____

**ONLINE ORDERING
AVAILABLE**
VISIT AMERICANFIXTURE.COM

COMPANY NAME _____

BOOTH NUMBER _____

ORDERS AND BOOTH LAYOUT DUE BY APRIL 29, 2022

American Fixture & Display Corp.

Phone: (718) 463-2176 • Fax: (718) 463-4302

Email: orders@americanfixture.com • Web: americanfixture.com

Please complete company name, credit card information and booth layout located on the final pages. This is required to process your order.

ECB A P d a e p A [] } ^ & c j } A ^ A A A C I E E A ^ A @ . s e e ^ A @ e A ^ A } A ^ * [c a e r a s ^ A U ^ A A O z @ a a j } . A j A s ^ . ^ A A { [[c O [[c ^ E j A j A e @ a j ! . E O E ^ i a e e A D e r c ^ A B A O a] j e s A O [!] E @ e A e ^ A A A q A e e a ^ A j [^ & c j } ^ A @ A ^ A j a A ^ { a a j } ^ A j A @ A j } [] i a e A e d e a . E U ^ e e ^ A [e ^ A ^ A ^ A] @) ^ A i a ^ A [e a e e ^ A] e a E A

CASES ARE RENTED FOR DISPLAY PURPOSES ONLY AND WE DO NOT WARRANT THE SAFETY OR SECURITY THEREOF. WE ARE NOT LIABLE FOR CONTENTS, DAMAGE OR BREAKAGE AFTER CASES HAVE BEEN DELIVERED.

Designer Line

DESIGNER LINE FEATURES:



- Fluorescent lighting
- Halogen lighting available for an additional \$50 per showcase
- LED lighting available for an additional \$85 per showcase
- Aluminum frame
- Textured designer gray formica exterior
- Glass sides
- Mirrored sliding doors with lock
- Rear storage area with lock in half and quarter vision only
- Available in 4', 5' and 6' lengths and corner cases
- 39" high and 20" deep
- Showcases are available in full, half and quarter vision
- Corner cases are available in half and quarter vision only

SIZE	QUANTITY			ADVANCED PRICE	PRICE FOR ORDERS RECEIVED AFTER 04/29/2022	SHOW SITE PRICE	TOTAL
	FULL VISION	HALF VISION	QUARTER VISION				
4 FOOT				\$395.00	\$470.00	\$595.00	
5 FOOT				\$395.00	\$470.00	\$595.00	
6 FOOT				\$395.00	\$470.00	\$595.00	
34" CORNER	X			\$410.00	\$485.00	\$610.00	
42" CORNER	X	X		\$430.00	\$505.00	\$630.00	

* MANDATORY ELECTRIC FEE - Add \$25.00 per showcase \$ _____

Add \$50.00 per showcase for Halogen lighting \$ _____

Add \$85.00 per showcase for LED lighting \$ _____

SUBTOTAL \$ _____

8.375% SALES TAX \$ _____

TOTAL DUE \$ _____

COMPANY NAME _____

BOOTH NUMBER _____

**ONLINE ORDERING
AVAILABLE**
VISIT AMERICANFIXTURE.COM

ORDERS AND BOOTH LAYOUT DUE BY APRIL 29, 2022

American Fixture & Display Corp.

Phone: (718) 463-2176 • Fax: (718) 463-4302

Email: orders@americanfixture.com • Web: americanfixture.com

Please complete company name, credit card information and booth layout located on the final pages. This is required to process your order.

We warrant the safety and security of the contents of the cases during the rental period. We do not warrant the safety or security of the contents after the cases have been delivered. We are not liable for contents, damage or breakage after cases have been delivered.

CASES ARE RENTED FOR DISPLAY PURPOSES ONLY AND WE DO NOT WARRANT THE SAFETY OR SECURITY THEREOF. WE ARE NOT LIABLE FOR CONTENTS, DAMAGE OR BREAKAGE AFTER CASES HAVE BEEN DELIVERED.

Deluxe Line

DELUXE LINE FEATURES:

- Fluorescent lighting
- LED lighting available for an additional \$85 per showcase
- Brushed gold frame
- Glossy black formica exterior
- Glass sides
- Mirrored sliding doors with lock
- Rear storage area with lock
- Available in 4', 5' and 6' lengths and corner cases
- 38" high and 20" deep
- Showcases and corner cases available in half vision and quarter vision only



HALF VISION SHOWN HERE

SIZE	QUANTITY		ADVANCED PRICE	PRICE FOR ORDERS RECEIVED AFTER 04/29/2022	SHOW SITE PRICE	TOTAL
	HALF VISION	QUARTER VISION				
4 FOOT			\$415.00	\$490.00	\$615.00	
5 FOOT			\$415.00	\$490.00	\$615.00	
6 FOOT			\$415.00	\$490.00	\$615.00	
34" CORNER			\$440.00	\$515.00	\$640.00	

* MANDATORY ELECTRIC FEE - Add \$25.00 per showcase \$ _____

Add \$85.00 per showcase for LED lighting \$ _____

SUBTOTAL \$ _____

8.375% SALES TAX \$ _____

TOTAL DUE \$ _____

COMPANY NAME _____

BOOTH NUMBER _____



ORDERS AND BOOTH LAYOUT DUE BY APRIL 29, 2022

American Fixture & Display Corp.

Phone: (718) 463-2176 • Fax: (718) 463-4302

Email: orders@americanfixture.com • Web: americanfixture.com

Please complete company name, credit card information and booth layout located on the final pages. This is required to process your order.

ECB A P d a e p A [] } ^ & c j } A ^ A A A C I E E A ^ A @ . & e e ^ A @ e A ^ A } A ^ * [c a e e a s ^ A U ^ a A O e Q e a e j } . A j A s ^ . I ^ A s A { [[c Q A [c ^ E j A j A e Q e a j] . E Q E ^ i a e e j A d e c i ^ A B A O e] j e s A O [] E e Q e A e i ^ a a A q A e . a o s ^ A j [] ^ & c j } A @ A ^ A e j a A ^ { a e j } A e j A e @ A e j] [] i a e e A e d e e . E U ^ e e ^ A [e I A ^ A ^ A] @) ^ A j a ^ A [e a e e A] e a E A

Elite Line

ELITE LINE FEATURES:

- Halogen lighting
- LED lighting available for an additional \$60 per showcase
- Brushed gold frame
- Verdigris formica exterior
- Glass sides
- Mirrored sliding doors with lock
- Rear storage area with lock
- Available in 4', 5' and 6' lengths and corner cases
- 39" high and 20" deep
- Showcases and corner cases are available in half vision and quarter vision only



QUARTER VISION SHOWN HERE

SIZE	QUANTITY		ADVANCED PRICE	PRICE FOR ORDERS RECEIVED AFTER 04/29/2022	SHOW SITE PRICE	TOTAL
	HALF VISION	QUARTER VISION				
4 FOOT			\$440.00	\$515.00	\$640.00	
5 FOOT			\$440.00	\$515.00	\$640.00	
6 FOOT			\$440.00	\$515.00	\$640.00	
34" CORNER			\$465.00	\$540.00	\$665.00	

* MANDATORY ELECTRIC FEE - Add \$25.00 per showcase \$ _____

Add \$60.00 per showcase for LED lighting \$ _____

SUBTOTAL \$ _____

8.375% SALES TAX \$ _____

TOTAL DUE \$ _____

**ONLINE ORDERING
AVAILABLE**
VISIT AMERICANFIXTURE.COM

COMPANY NAME _____

BOOTH NUMBER _____

ORDERS AND BOOTH LAYOUT DUE BY APRIL 29, 2022

American Fixture & Display Corp.

Phone: (718) 463-2176 • Fax: (718) 463-4302

Email: orders@americanfixture.com • Web: americanfixture.com

Please complete company name, credit card information and booth layout located on the final pages. This is required to process your order.

ECB A P d a e p A () } ^ & c j } A ^ A A C I E E A ^ A @ . & e e A @ e A ^ A } A ^ * [c a e e a A ~ A U ^ a A O z @ e a j } . A j A ~ . ^ A e A { [[c @ [c e B A j A e @ e a j : • E O E N i a e e A D e a r c i A B A O e] j e s A O [i] E e A e i ^ a A q A e • a o s ^ B j | | ^ & c j * A @ A ^ A e j a A ^ { a e j * A e j A e @ A e j } | [] i a e e A e d e e • E U j ^ e e A j [e A A ^ j] @ } ^ A i a ^ i • A [e a e e] e a E A

Ultra Line

FOR THE BEST SELECTION OF THE **ULTRA LINE**,
ORDERS & BOOTH LAYOUTS MUST BE RECEIVED BY
APRIL 22, 2022



BLACK/FULL VISION SHOWN HERE

ULTRA LINE FEATURES:

- LED lighting available in:
 - 3000K Yellow
 - 6000K White
- Aluminum frame
- Black or matte white exterior
- Glass sides
- Glass sliding doors with lock
- Rear storage area with lock available on half and quarter vision showcases only
- Available in 4', 5', and 6' lengths and corner cases
- 41½" high and 20" deep (48" corner is 27½" deep)
- Showcases and corner cases are available in full vision, half vision, and quarter vision

SIZE	QUANTITY			BLACK or WHITE	3000K or 6000K	ADVANCED PRICE	PRICE FOR ORDERS RECEIVED AFTER 04/22/2022	SHOW SITE PRICE	TOTAL
	FULL VISION	HALF VISION	QUARTER VISION						
4 FOOT						\$500.00	\$575.00	\$700.00	
5 FOOT						\$500.00	\$575.00	\$700.00	
6 FOOT						\$500.00	\$575.00	\$700.00	
34" CORNER						\$525.00	\$600.00	\$725.00	
48" CORNER						\$545.00	\$620.00	\$745.00	

* MANDATORY ELECTRIC FEE - Add \$25.00 per showcase \$ _____

SUBTOTAL \$ _____

8.375% SALES TAX \$ _____

TOTAL DUE \$ _____

COMPANY NAME _____

BOOTH NUMBER _____



ULTRA LINE ORDERS AND BOOTH LAYOUT DUE BY APRIL 22, 2022

American Fixture & Display Corp.

Phone: (718) 463-2176 • Fax: (718) 463-4302

Email: orders@americanfixture.com • Web: americanfixture.com

Please complete company name, credit card information and booth layout located on the final pages. This is required to process your order.

© 2022 American Fixture & Display Corp. All rights reserved. This document is the property of American Fixture & Display Corp. and is not to be distributed, copied, or used in any way without the express written consent of American Fixture & Display Corp.

CASES ARE RENTED FOR DISPLAY PURPOSES ONLY AND WE DO NOT WARRANT THE SAFETY OR SECURITY THEREOF. WE ARE NOT LIABLE FOR CONTENTS, DAMAGE OR BREAKAGE AFTER CASES HAVE BEEN DELIVERED.

Accent Cube



WHITE SHOWN HERE

WHITE or DESIGNER LINES

- Aluminum frame
- Halogen lighting
- LED lighting available for an additional \$45
- Standard white or textured gray formica exterior
- 18" wide x 18" deep x 70" high
- 18" wide x 18" deep x 18" high glass display area
- Hinged frameless glass door with lock
- Storage area with lock

DELUXE or ELITE LINES

- Brushed gold frame
- Halogen lighting
- LED lighting available for an additional \$45
- Glossy black or verdigris formica exterior
- 18" wide x 18" deep x 70" high
- 18" wide x 18" deep x 18" high glass display area
- Hinged frameless glass door with lock
- Storage area with lock



DELUXE SHOWN HERE

STYLE	QUANTITY	ADVANCED PRICE	PRICE FOR ORDERS RECEIVED AFTER 04/29/2022	SHOW SITE PRICE	TOTAL
STANDARD WHITE		\$390.00	\$465.00	\$590.00	
DESIGNER		\$390.00	\$465.00	\$590.00	
DELUXE		\$390.00	\$465.00	\$590.00	
ELITE		\$390.00	\$465.00	\$590.00	

* MANDATORY ELECTRIC FEE - Add \$25.00 per showcase \$ _____

Add \$45.00 per accent cube for LED lighting \$ _____

SUBTOTAL \$ _____

8.375% SALES TAX \$ _____

TOTAL DUE \$ _____

COMPANY NAME _____

BOOTH NUMBER _____

ONLINE ORDERING AVAILABLE
 VISIT AMERICANFIXTURE.COM

ORDERS AND BOOTH LAYOUT DUE BY APRIL 29, 2022

American Fixture & Display Corp.

Phone: (718) 463-2176 • Fax: (718) 463-4302

Email: orders@americanfixture.com • Web: americanfixture.com

Please complete company name, credit card information and booth layout located on the final pages. This is required to process your order.

ECB A P d e a p A [] } ^ & c j } A ^ A A C I E E A ^ A @ . & e e ^ A @ e A ^ A } A ^ * [c a e e a s ^ A ^ a A O z Q e a i j } • A j A s • ^ A A A { [[c Q [c ^ E j A j A e Q e a j] • E O E ^ i a e e A D e r c ^ A B A O e } j e s A O [i] E e Q e A e ^ A a A q f A e • a o s ^ A j [^ & c j } A @ A ^ A e j a A ^ { a i j } A e A e d e • E U ^ e ^ A [e ^ A ^ A ^ A] A j i a ^ A [e a e e] e a E A

Tower



**DELUXE
SHOWN HERE**

CHOICES:

- **STANDARD WHITE** Aluminum frame with a matte white formica exterior
- **DESIGNER** Aluminum frame with a textured gray formica exterior
- **DELUXE** Brushed gold frame with a glossy black formica exterior
- **ELITE** Brushed gold frame with a verdigris formica exterior

FEATURES:

- Halogen lighting
- LED lighting available for an additional \$45 per tower
- 6" canopy
- 3 adjustable glass shelves
- Clear glass on four sides
- Hinged framed door with lock
- 20" wide x 20" deep x 80" high
- 20" wide x 20" deep x 54" high glass display area



**DESIGNER
SHOWN HERE**

STYLE	QUANTITY	ADVANCED PRICE	PRICE FOR ORDERS RECEIVED AFTER 04/29/2022	SHOW SITE PRICE	TOTAL
STANDARD WHITE		\$400.00	\$475.00	\$600.00	
DESIGNER		\$400.00	\$475.00	\$600.00	
DELUXE		\$400.00	\$475.00	\$600.00	
ELITE		\$400.00	\$475.00	\$600.00	

* MANDATORY ELECTRIC FEE - Add \$25.00 per showcase \$ _____

Add \$45.00 per tower for LED lighting \$ _____

SUBTOTAL \$ _____

8.375% SALES TAX \$ _____

TOTAL DUE \$ _____

COMPANY NAME _____

BOOTH NUMBER _____

**ONLINE ORDERING
AVAILABLE**
 VISIT AMERICANFIXTURE.COM

ORDERS AND BOOTH LAYOUT DUE BY APRIL 29, 2022

American Fixture & Display Corp.

Phone: (718) 463-2176 • Fax: (718) 463-4302

Email: orders@americanfixture.com • Web: americanfixture.com

Please complete company name, credit card information and booth layout located on the final pages. This is required to process your order.

ECB A P & d a e p A [] } ^ & c j } A ^ A - A C I E C A ^ A @ . & e e ^ A @ e A ^ A } A ^ * [c a e e a S ^ A ^ a A O z @ a a j } . A j A j ^ ^ A A { [[c O A [c A B A j A e @ a j ! . E O E ^ i a e e A D e r c i ^ A B O a] j e s A O [!] E C e A e i ^ a a A q f A e . a c h ^ B j [^ & c j * A @ A ^ A j a A ^ { a a j * A a j A @ A j] [] i a e A e d e . E U ^ e ^ A [e ^ A ^ A ^] @) ^ A i a ^ A [c a e e A] e a E A

Museum Pedestal



CHOICES:

- WHITE: Aluminum frame with matte white formica exterior
- DELUXE: Brushed gold frame with glossy black formica exterior
- BEIGE: Brushed gold frame with beige formica exterior

FEATURES:

- Halogen lighting
- LED lighting available for an additional \$60 per museum pedestal
- 8" canopy
- Glass doors with lock
- Storage area with lock
- 30" wide x 20" deep x 70" high
- 30" wide x 20" deep x 20" high glass display area

STYLE	QUANTITY	ADVANCED PRICE	PRICE FOR ORDERS RECEIVED AFTER 04/29/2022	SHOW SITE PRICE	TOTAL
White		\$445.00	\$520.00	\$645.00	
Deluxe		\$445.00	\$520.00	\$645.00	
Beige		\$445.00	\$520.00	\$645.00	

* MANDATORY ELECTRIC FEE - Add \$25.00 per showcase \$ _____

Add \$60.00 per museum pedestal for LED lighting \$ _____

SUBTOTAL \$ _____

8.375% SALES TAX \$ _____

TOTAL DUE \$ _____

COMPANY NAME _____

BOOTH NUMBER _____

**ONLINE ORDERING
AVAILABLE**
VISIT AMERICANFIXTURE.COM

ORDERS AND BOOTH LAYOUT DUE BY APRIL 29, 2022

American Fixture & Display Corp.

Phone: (718) 463-2176 • Fax: (718) 463-4302

Email: orders@americanfixture.com • Web: americanfixture.com

Please complete company name, credit card information and booth layout located on the final pages. This is required to process your order.

ECB A P d e a p A [] } ^ & c j } A ^ A A A C I E E A ^ A @ . & e e ^ A @ e A ^ A } A ^ * [c a e a s ^ A ^ a A O z @ e a j } . A j A ^ . ^ A A { [[c A [c ^ E j A j A e @ e a j] . E O E ^ i a e e A D e a r c ^ A B A O e] j e s A O [!] E E e A e i ^ A a A q A e . a c h ^ A j [^ & c j } A @ A ^ A e j a A ^ { a c j } A e j A @ A e j] [] i a e A e d e . E U ^ e ^ A [e A A ^ A] @) ^ A i a ^ A [e A e A] e a E A

Boutique Case



DELUXE BOUTIQUE WITH
SOLID BACK SHOWN HERE

CHOICES:

- DESIGNER: Aluminum frame with textured gray formica exterior
- DELUXE: Brushed gold frame with glossy black formica exterior

FEATURES:

- Fluorescent lighting
- LED lighting available for an additional \$60 per boutique case
- 5" canopy
- Solid back or glass back
- 3 rows of adjustable glass shelves
- Glass doors with lock
- Storage area with lock
- 48" wide x 13" deep x 76" high
- 48" wide x 13" deep x 44" high glass display area

STYLE	QUANTITY		ADVANCED PRICE	PRICE FOR ORDERS RECEIVED AFTER 04/29/2022	SHOW SITE PRICE	TOTAL
	SOLID BACK	GLASS BACK				
Designer			\$475.00	\$550.00	\$675.00	
Deluxe			\$475.00	\$550.00	\$675.00	

* MANDATORY ELECTRIC FEE - Add \$25.00 per showcase \$ _____

Add \$60.00 per boutique case for LED lighting \$ _____

SUBTOTAL \$ _____

8.375% SALES TAX \$ _____

TOTAL DUE \$ _____



COMPANY NAME _____

BOOTH NUMBER _____

ORDERS AND BOOTH LAYOUT DUE BY APRIL 29, 2022

American Fixture & Display Corp.

Phone: (718) 463-2176 • Fax: (718) 463-4302

Email: orders@americanfixture.com • Web: americanfixture.com

Please complete company name, credit card information and booth layout located on the final pages. This is required to process your order.

ECB A P d e a b l } } ^ & c j } A ^ A A C l e e A ^ A @ . s e e ^ A @ e A ^ A } A ^ * [c a e a s ^ A ^ a A O z Q u a j } . A j A ^ * ^ A A { [[c Q [c ^ E j A j A e Q u a j : • E Q E ^ i s e e A D e r c ^ A B A O e] j e s A O [!] E Q e A e i ^ a a A q A e • a c h ^ B j | ^ & c j * A @ A ^ A j a A ^ { a c j * A e j A @ A j } | [] i a e A e d e • E U ^ e ^ A [e ^ A ^ A ^] @) ^ A i a ^ A [c a e s ^] e a E A

SNEEZE GUARD

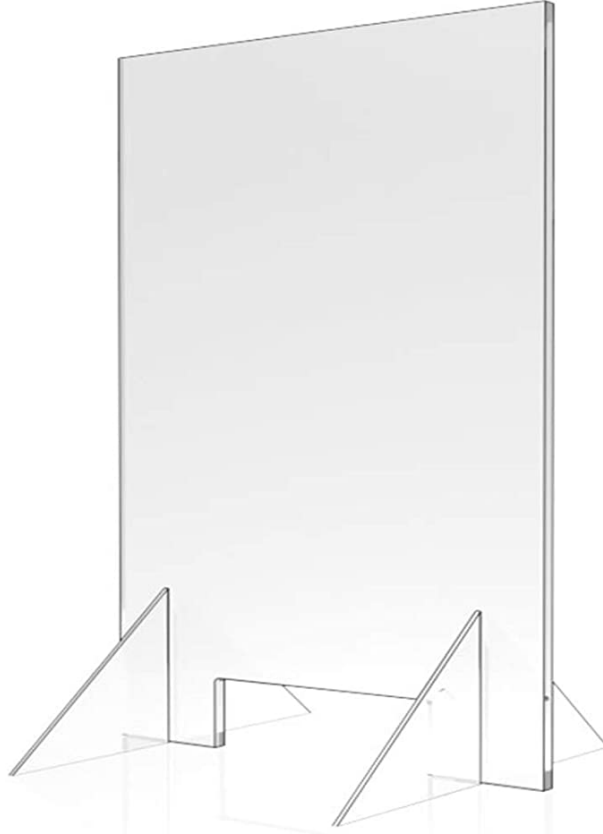

*Perfect for
placement on
your showcase
or table top*

FEATURES:

- 24" Wide x 30" High
- Pass Through By 4" High X 12" Wide

QUANTITY	ADVANCED PRICE	PRICE FOR ORDERS RECEIVED AFTER 04/29/2022	TOTAL
	\$95.00	\$115.00	

**ONLINE ORDERING
AVAILABLE**
VISIT AMERICANFIXTURE.COM

SUBTOTAL \$ _____

8.375 % SALES TAX \$ _____

TOTAL DUE \$ _____

COMPANY NAME _____

BOOTH NUMBER _____

ORDERS AND BOOTH LAYOUT DUE BY APRIL 29, 2022

American Fixture & Display Corp.

Phone: (718) 463-2176 • Fax: (718) 463-4302

Email: orders@americanfixture.com • Web: americanfixture.com

If this product is not returned at the end of the event, you will automatically be charged \$150.00

Please complete company name, credit card information and booth layout located on the final pages. This is required to process your order.

Available Styles



FULL VISION SHOWCASE



HALF VISION SHOWCASE



QUARTER VISION SHOWCASE



CORNER SHOWCASE

Please complete company name, credit card information and booth layout located on the final pages. This is required to process your order.

Please note: Telephone orders not accepted.

CASES ARE RENTED FOR DISPLAY PURPOSES ONLY AND WE DO NOT WARRANT THE SAFETY OR SECURITY THEREOF. WE ARE NOT LIABLE FOR CONTENTS, DAMAGE OR BREAKAGE AFTER CASES HAVE BEEN DELIVERED.

Sample Layouts

10 FOOT X 10 FOOT CORNER BOOTHS

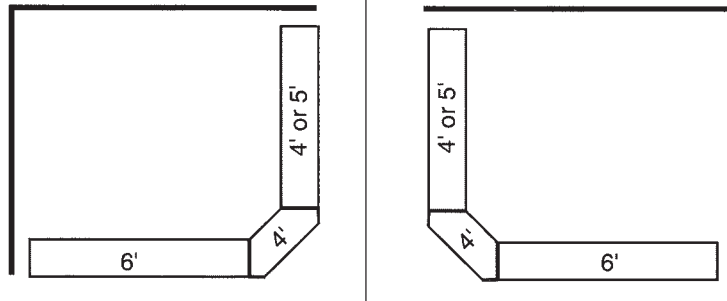

10 FOOT X 10 FOOT SINGLE BOOTHS

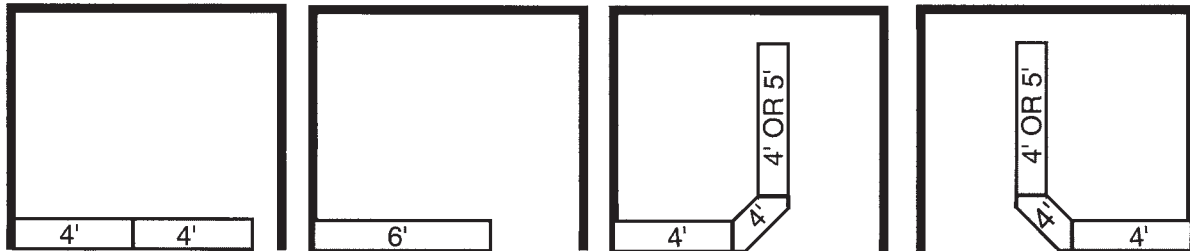

10 FOOT X 20 FOOT DOUBLE BOOTHS

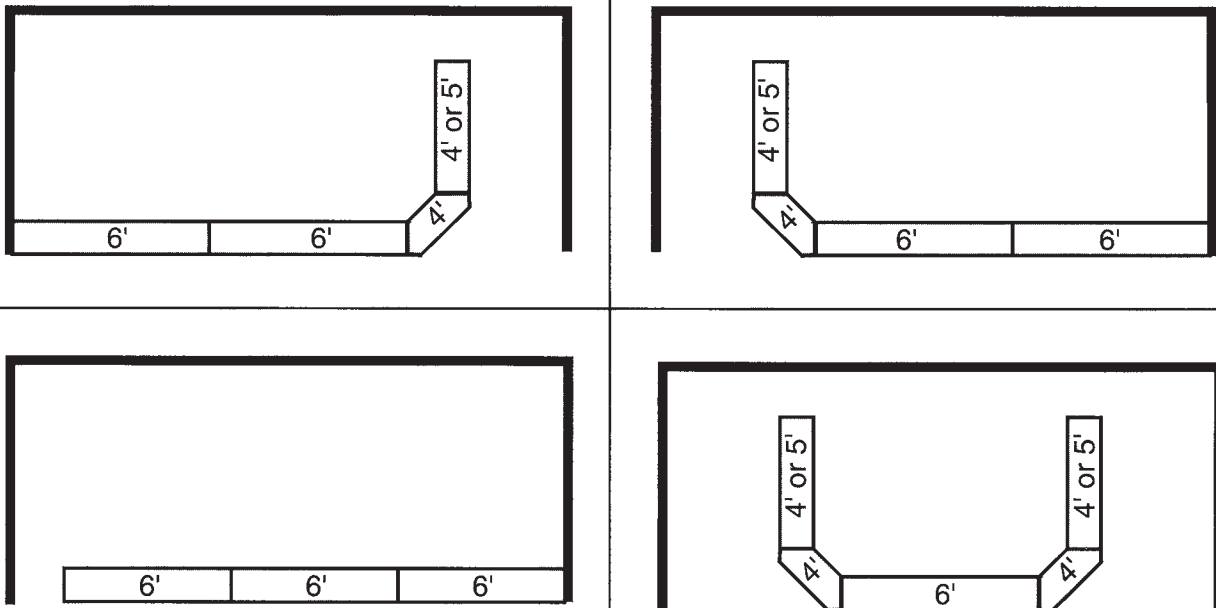

Please complete company name, credit card information and booth layout located on the final pages. This is required to process your order.

CASES ARE RENTED FOR DISPLAY PURPOSES ONLY AND WE DO NOT WARRANT THE SAFETY OR SECURITY THEREOF. WE ARE NOT LIABLE FOR CONTENTS, DAMAGE OR BREAKAGE AFTER CASES HAVE BEEN DELIVERED.

ELECTRICAL INFORMATION NON-LED LIGHTING

Standard White (Fluorescent)

4'	25 Watts
5'	30 Watts
6'	40 Watts
34" Corner	20 Watts

Designer & Deluxe (Fluorescent)

4'	25 Watts
5'	30 Watts
6'	40 Watts
34" Corner	20 Watts
42" Corner	30 Watts

Designer & Elite (Halogen)

4'	100 Watts
5'	120 Watts
6'	140 Watts
34" Corner	80 Watts
42" Corner	100 Watts

Tower (Halogen)

200 Watts

Museum Pedestal (Halogen)

300 Watts

Accent Cube (Halogen)

White & Designer	150 Watts
Deluxe & Elite	140 Watts

Boutique Case (Fluorescent)

84 Watts

ELECTRICAL INFORMATION

LED LIGHTING

Standard Case – White

4'	33 Watts
5'	42 Watts
6'	49 Watts
34" Corner	26 Watts

Deluxe & Designer Case

4'	42 Watts
5'	48 Watts
6'	54 Watts
34" Corner	36 Watts
42" Corner	42 Watts

Elite Case

4'	12 Watts
5'	15 Watts
6'	17 Watts
34" Corner	9 Watts
42" Corner	12 Watts

Ultra Case – 6000K

4'	42 Watts
5'	48 Watts
6'	54 Watts
34" Corner	36 Watts
48" Corner	90 Watts

Ultra Case – 3000K

4'	12 Watts
5'	15 Watts
6'	17 Watts
34" Corner	9 Watts
48" Corner	16 Watts

Tower

100 Watts

Museum Pedestal

36 Watts

Accent Cube

24 Watts

Boutique

84 Watts

AMERICAN FIXTURE & DISPLAY

THE SHOWCASE PEOPLE

BOOTH LAYOUT DIAGRAM

PLEASE INDICATE YOUR BOOTH DIMENSIONS AND THE MANNER IN WHICH YOU WOULD LIKE THE SHOWCASES PLACED IN YOUR BOOTH(S). ***THIS COMPLETED LAYOUT IS REQUIRED TO CONFIRM YOUR ORDER.***

Back of Booth

LENGTH _____ feet

WIDTH _____ feet

Front of Booth

EXHIBITOR NAME: _____

BOOTH NO: _____ BOOTH DIMENSIONS (LENGTH x WIDTH) _____ FEET

ORDERS AND BOOTH LAYOUT DUE BY APRIL 29, 2022 | ULTRA LINE DUE BY APRIL 22, 2022

American Fixture & Display Corp.
Phone: (718) 463-2176 • Fax: (718) 463-4302
Email: orders@americanfixture.com • Web: americanfixture.com

Please complete company name, credit card information and booth layout located on the final pages. This is required to process your order.

CASES ARE RENTED FOR DISPLAY PURPOSES ONLY AND WE DO NOT WARRANT THE SAFETY OR SECURITY THEREOF. WE ARE NOT LIABLE FOR CONTENTS, DAMAGE OR BREAKAGE AFTER CASES HAVE BEEN DELIVERED.

SHOWCASE ORDER FORM

Please complete the following information and submit it along with your showcase selections and booth layout diagram (previous page).

CONTACT INFORMATION

COMPANY NAME: _____

ADDRESS: _____

CITY, STATE, ZIP CODE: _____

POINT OF CONTACT NAME: _____

EMAIL ADDRESS: _____

PHONE: _____ FAX: _____

BOOTH NO(S): _____

PAYMENT INFORMATION

DISCOVER / AMEX / VISA / MC #: _____ EXP DATE: _____

NAME ON CARD: _____ SEC CODE: _____

SIGNATURE: _____ DATE: _____

ORDERS AND BOOTH LAYOUT DUE BY APRIL 29, 2022 | ULTRA LINE DUE BY APRIL 22, 2022

TERMS AND CONDITIONS OF RENTAL

American Fixture & Display Corp. and AFD Delaware, Inc. (together, the "Company") shall not be liable for failure to deliver the displays ("Company's Rental Property") or delays occasioned by causes beyond its control, including, but not limited to, strikes, lockouts, fires, flood, hurricanes, war, acts of God, acts of terrorism, labor disputes, pandemics, epidemics, viruses, or delays or interruption of carriers and in no event shall be liable for consequential damages.

The Company shall have the right to charge the full rental price of the Company's Rental Property to the customer ("Lessee") on any orders (i) canceled after the deadline date; or (ii) that have been delivered to the location of the rental, regardless of whether the event takes place.

Glass shelves must be properly installed by Lessee and not overloaded with merchandise. To avoid breaking of shelves, personal injury and damage to merchandise, the Lessee must use reasonable discretion in the amount of weight placed on the glass shelves. Installation and loading of the glass shelves is beyond the Company's control and the Company shall not be responsible for broken glass, damage of merchandise or personal injury related thereto.

In the event of any damage to the Company Rental Property during the rental period, excluding normal wear and tear, the Lessee shall pay to Company, on demand, the full cost of repair or replacement of such damaged display cases. Lessee further agrees to accept full responsibility and liability, and Lessee shall indemnify, defend and hold harmless Company, for any injury to Lessee, for any damage to the property of Lessee, for any injury to any other person(s), for any damage to the property of any other person(s) and any other loss that may result through the use or misuse of the Company's Rental Property. Lessee agrees and acknowledges that Lessee is subject to additional charges if Lessee fails to return the Company's Rental Property to Company or fails to make the Company's Rental Property available to Company for pick-up at the time and date mutually agreed to by both parties.

Lessee agrees to accept full responsibility and liability, and shall indemnify, defend and hold harmless Company and its agents, employees, officers or directors from and against any and all liability, claims, demands (whether or not groundless, false, or fraudulent), costs, damages, losses, judgments, or awards, including legal and attorney fees, brought by a third party or parties and arising out of or in any way connected with any act or omission of Lessee or its employees or other persons.

The Company's Rental Property are rented for display purposes only and Company does not warrant the safety or security thereof. Company shall not be liable for contents, damage or breakage after the Company's Rental Property have been delivered.

Standard White Line

STANDARD WHITE FEATURES:

- Fluorescent lighting
- LED lighting available for an additional \$85 per showcase
- Aluminum frame
- Matte white formica exterior
- Solid sides
- Sliding doors with lock (no mirrors)
- Rear storage area with lock in half and quarter vision cases
- Available in 4', 5' and 6' lengths and corner cases
- 38" high and 20" deep
- Showcases are available in full, half and quarter vision
- Corner cases are available in half and quarter vision only

SIZE	QUANTITY			ADVANCED PRICE	PRICE FOR ORDERS RECEIVED AFTER 04/29/2022	SHOW SITE PRICE	TOTAL
	FULL VISION	HALF VISION	QUARTER VISION				
4 FOOT				\$370.00	\$445.00	\$570.00	
5 FOOT				\$370.00	\$445.00	\$570.00	
6 FOOT				\$370.00	\$445.00	\$570.00	
34" CORNER	X			\$390.00	\$465.00	\$590.00	

* MANDATORY ELECTRIC FEE - Add \$25.00 per showcase \$ _____

Add \$85.00 per showcase for LED lighting \$ _____

SUBTOTAL \$ _____

8.375% SALES TAX \$ _____

TOTAL DUE \$ _____

COMPANY NAME _____

BOOTH NUMBER _____

**ONLINE ORDERING
AVAILABLE**
VISIT AMERICANFIXTURE.COM

ORDERS AND BOOTH LAYOUT DUE BY APRIL 29, 2022

American Fixture & Display Corp.

Phone: (718) 463-2176 • Fax: (718) 463-4302

Email: orders@americanfixture.com • Web: americanfixture.com

Please complete company name, credit card information and booth layout located on the final pages. This is required to process your order.

ECB A P d a e p A () } ^ & c j } A ^ A A A C I E E A ^ A @ . & e e A @ e A ^ A } A ^ * [c a e e a A ^ A ^ A A O z @ e a j } • A j A } • I ^ A A { [[c @ [c e B A j A e @ e a j : • B O I ^ i a e e A D e a C i ^ A B A O e] j e s A O [i] E e A e i ^ A a A q A e • a o h ^ B j | | ^ & c j * A @ A ^ A e j a A ^ { a e j * A e j A e A e j | |] i a e A e d e a • E U ^ e e A j [e I A ^ A ^ A] @) ^ A i a ^ A [e A e e A] e a E A

CASES ARE RENTED FOR DISPLAY PURPOSES ONLY AND WE DO NOT WARRANT THE SAFETY OR SECURITY THEREOF. WE ARE NOT LIABLE FOR CONTENTS, DAMAGE OR BREAKAGE AFTER CASES HAVE BEEN DELIVERED.



**GLOBAL
GEMSTONE**

**Sands Expo &
The Venetian
June 9 - 13, 2022**

Designer Line

DESIGNER LINE FEATURES:



- Fluorescent lighting
- Halogen lighting available for an additional \$50 per showcase
- LED lighting available for an additional \$85 per showcase
- Aluminum frame
- Textured designer gray formica exterior
- Glass sides
- Mirrored sliding doors with lock
- Rear storage area with lock in half and quarter vision only
- Available in 4', 5' and 6' lengths and corner cases
- 39" high and 20" deep
- Showcases are available in full, half and quarter vision
- Corner cases are available in half and quarter vision only

SIZE	QUANTITY			ADVANCED PRICE	PRICE FOR ORDERS RECEIVED AFTER 04/29/2022	SHOW SITE PRICE	TOTAL
	FULL VISION	HALF VISION	QUARTER VISION				
4 FOOT				\$395.00	\$470.00	\$595.00	
5 FOOT				\$395.00	\$470.00	\$595.00	
6 FOOT				\$395.00	\$470.00	\$595.00	
34" CORNER	X			\$410.00	\$485.00	\$610.00	
42" CORNER	X	X		\$430.00	\$505.00	\$630.00	

* MANDATORY ELECTRIC FEE - Add \$25.00 per showcase \$ _____

Add \$50.00 per showcase for Halogen lighting \$ _____

Add \$85.00 per showcase for LED lighting \$ _____

SUBTOTAL \$ _____

8.375% SALES TAX \$ _____

TOTAL DUE \$ _____

**ONLINE ORDERING
AVAILABLE
VISIT AMERICANFIXTURE.COM**

COMPANY NAME _____

BOOTH NUMBER _____

ORDERS AND BOOTH LAYOUT DUE BY APRIL 29, 2022

American Fixture & Display Corp.

Phone: (718) 463-2176 • Fax: (718) 463-4302

Email: orders@americanfixture.com • Web: americanfixture.com

Please complete company name, credit card information and booth layout located on the final pages. This is required to process your order.

ECB A P d a e p A () ^ & c j } A ^ A A C I E C A ^ A @ . s e e ^ A @ e A ^ A } A ^ * [c a e a s ^ A ^ a A O z @ a a j } . A / A ^ . ^ A A { [[c a [c ^ E A A I A e @ a j ! . E O E ^ A s e e A D a r c ^ A B A O a] j e s A O [!] E C e A e ^ A A A q A e . a o s ^ A / | ^ & c j * A @ A ^ A e j a A ^ { a a j * A e j A @ A e j | !] i a e A e d e a . E U ^ e ^ A [e A A ^ A] @) ^ A i a ^ . A [c a e s ^ A] e a E A

CASES ARE RENTED FOR DISPLAY PURPOSES ONLY AND WE DO NOT WARRANT THE SAFETY OR SECURITY THEREOF. WE ARE NOT LIABLE FOR CONTENTS, DAMAGE OR BREAKAGE AFTER CASES HAVE BEEN DELIVERED.

Deluxe Line

DELUXE LINE FEATURES:



HALF VISION SHOWN HERE

- Fluorescent lighting
- LED lighting available for an additional \$85 per showcase
- Brushed gold frame
- Glossy black formica exterior
- Glass sides
- Mirrored sliding doors with lock
- Rear storage area with lock
- Available in 4', 5' and 6' lengths and corner cases
- 38" high and 20" deep
- Showcases and corner cases available in half vision and quarter vision only

SIZE	QUANTITY		ADVANCED PRICE	PRICE FOR ORDERS RECEIVED AFTER 04/29/2022	SHOW SITE PRICE	TOTAL
	HALF VISION	QUARTER VISION				
4 FOOT			\$415.00	\$490.00	\$615.00	
5 FOOT			\$415.00	\$490.00	\$615.00	
6 FOOT			\$415.00	\$490.00	\$615.00	
34" CORNER			\$440.00	\$515.00	\$640.00	

* MANDATORY ELECTRIC FEE - Add \$25.00 per showcase \$ _____

Add \$85.00 per showcase for LED lighting \$ _____

SUBTOTAL \$ _____

8.375% SALES TAX \$ _____

TOTAL DUE \$ _____

COMPANY NAME _____

BOOTH NUMBER _____

ONLINE ORDERING AVAILABLE
VISIT AMERICANFIXTURE.COM

ORDERS AND BOOTH LAYOUT DUE BY APRIL 29, 2022

American Fixture & Display Corp.

Phone: (718) 463-2176 • Fax: (718) 463-4302

Email: orders@americanfixture.com • Web: americanfixture.com

Please complete company name, credit card information and booth layout located on the final pages. This is required to process your order.

PLEASE PRINT CLEARLY AND IN INK. ALL INFORMATION MUST BE PRINTED ON THE FRONT SIDE OF THE ORDER FORM. ALL ORDERS ARE SUBJECT TO OUR CATALOGUE TERMS AND CONDITIONS. ALL PRICES ARE IN U.S. DOLLARS. ALL PRICES ARE NET. ALL PRICES ARE SUBJECT TO CHANGE WITHOUT NOTICE. ALL PRICES ARE SUBJECT TO AVAILABILITY. ALL PRICES ARE SUBJECT TO CREDIT REVIEW. ALL PRICES ARE SUBJECT TO CREDIT REVIEW. ALL PRICES ARE SUBJECT TO CREDIT REVIEW.

CASES ARE RENTED FOR DISPLAY PURPOSES ONLY AND WE DO NOT WARRANT THE SAFETY OR SECURITY THEREOF. WE ARE NOT LIABLE FOR CONTENTS, DAMAGE OR BREAKAGE AFTER CASES HAVE BEEN DELIVERED.

Elite Line

ELITE LINE FEATURES:

- Halogen lighting
- LED lighting available for an additional \$60 per showcase
- Brushed gold frame
- Verdigris formica exterior
- Glass sides
- Mirrored sliding doors with lock
- Rear storage area with lock
- Available in 4', 5' and 6' lengths and corner cases
- 39" high and 20" deep
- Showcases and corner cases are available in half vision and quarter vision only



SIZE	QUANTITY		ADVANCED PRICE	PRICE FOR ORDERS RECEIVED AFTER 04/29/2022	SHOW SITE PRICE	TOTAL
	HALF VISION	QUARTER VISION				
4 FOOT			\$440.00	\$515.00	\$640.00	
5 FOOT			\$440.00	\$515.00	\$640.00	
6 FOOT			\$440.00	\$515.00	\$640.00	
34" CORNER			\$465.00	\$540.00	\$665.00	

* MANDATORY ELECTRIC FEE - Add \$25.00 per showcase \$ _____

Add \$60.00 per showcase for LED lighting \$ _____

SUBTOTAL \$ _____

8.375% SALES TAX \$ _____

TOTAL DUE \$ _____

COMPANY NAME _____

BOOTH NUMBER _____

**ONLINE ORDERING
AVAILABLE**
VISIT AMERICANFIXTURE.COM

ORDERS AND BOOTH LAYOUT DUE BY APRIL 29, 2022

American Fixture & Display Corp.

Phone: (718) 463-2176 • Fax: (718) 463-4302

Email: orders@americanfixture.com • Web: americanfixture.com

Please complete company name, credit card information and booth layout located on the final pages. This is required to process your order.

ECB A P d a e p A () } ^ & c j } A ^ A A C I E E A ^ A @ . & e e A @ e A ^ A } A ^ * [c a e e a A s ~ A U ^ a A O z Q e a i j } . A j A s ~ ^ A A s { [[c Q [c e E A j A e Q e a j ! • E O E N i a e e A D e a r c i A B A O e] j e s A O [!] E e Q e A e i A ^ a A q A e • a o s ~ A j | | ^ & c j * A e Q A ^ A s j a A ^ { a i j * A e A s @ A s j } | [] i a e e A e d e e • E U j ^ e e A j [e A A ^ A j] @) ^ A i a ^ A [e A e s] e a E A

Ultra Line

FOR THE BEST SELECTION OF THE **ULTRA LINE**,
ORDERS & BOOTH LAYOUTS MUST BE RECEIVED BY
APRIL 22, 2022



BLACK/FULL VISION SHOWN HERE

ULTRA LINE FEATURES:

- LED lighting available in:
 - 3000K Yellow
 - 6000K White
- Aluminum frame
- Black or matte white exterior
- Glass sides
- Glass sliding doors with lock
- Rear storage area with lock available on half and quarter vision showcases only
- Available in 4', 5', and 6' lengths and corner cases
- 41½" high and 20" deep (48" corner is 27½" deep)
- Showcases and corner cases are available in full vision, half vision, and quarter vision

SIZE	QUANTITY			BLACK or WHITE	3000K or 6000K	ADVANCED PRICE	PRICE FOR ORDERS RECEIVED AFTER 04/22/2022	SHOW SITE PRICE	TOTAL
	FULL VISION	HALF VISION	QUARTER VISION						
4 FOOT						\$500.00	\$575.00	\$700.00	
5 FOOT						\$500.00	\$575.00	\$700.00	
6 FOOT						\$500.00	\$575.00	\$700.00	
34" CORNER						\$525.00	\$600.00	\$725.00	
48" CORNER						\$545.00	\$620.00	\$745.00	

* MANDATORY ELECTRIC FEE - Add \$25.00 per showcase \$ _____

SUBTOTAL \$ _____

8.375% SALES TAX \$ _____

TOTAL DUE \$ _____

COMPANY NAME _____

BOOTH NUMBER _____

**ONLINE ORDERING
AVAILABLE**
VISIT AMERICANFIXTURE.COM

ULTRA LINE ORDERS AND BOOTH LAYOUT DUE BY APRIL 22, 2022

American Fixture & Display Corp.

Phone: (718) 463-2176 • Fax: (718) 463-4302

Email: orders@americanfixture.com • Web: americanfixture.com

Please complete company name, credit card information and booth layout located on the final pages. This is required to process your order.

© 2022 American Fixture & Display Corp. All rights reserved. This document is the property of American Fixture & Display Corp. and is to be used for informational purposes only. It is not to be reproduced, distributed, or used in any way without the prior written permission of American Fixture & Display Corp. The information contained herein is subject to change without notice. American Fixture & Display Corp. is not responsible for any errors or omissions in this document. American Fixture & Display Corp. is not liable for any damages, including consequential, special, or punitive damages, arising from the use of this document. American Fixture & Display Corp. is not liable for any loss of data or information, or any other damages, arising from the use of this document. American Fixture & Display Corp. is not liable for any damages, including consequential, special, or punitive damages, arising from the use of this document. American Fixture & Display Corp. is not liable for any loss of data or information, or any other damages, arising from the use of this document.

CASES ARE RENTED FOR DISPLAY PURPOSES ONLY AND WE DO NOT WARRANT THE SAFETY OR SECURITY THEREOF. WE ARE NOT LIABLE FOR CONTENTS, DAMAGE OR BREAKAGE AFTER CASES HAVE BEEN DELIVERED.

Accent Cube



WHITE
SHOWN HERE

WHITE or DESIGNER LINES

- Aluminum frame
- Halogen lighting
- LED lighting available for an additional \$45
- Standard white or textured gray formica exterior
- 18" wide x 18" deep x 70" high
- 18" wide x 18" deep x 18" high glass display area
- Hinged frameless glass door with lock
- Storage area with lock

DELUXE or ELITE LINES

- Brushed gold frame
- Halogen lighting
- LED lighting available for an additional \$45
- Glossy black or verdigris formica exterior
- 18" wide x 18" deep x 70" high
- 18" wide x 18" deep x 18" high glass display area
- Hinged frameless glass door with lock
- Storage area with lock



DELUXE
SHOWN HERE

STYLE	QUANTITY	ADVANCED PRICE	PRICE FOR ORDERS RECEIVED AFTER 04/29/2022	SHOW SITE PRICE	TOTAL
STANDARD WHITE		\$390.00	\$465.00	\$590.00	
DESIGNER		\$390.00	\$465.00	\$590.00	
DELUXE		\$390.00	\$465.00	\$590.00	
ELITE		\$390.00	\$465.00	\$590.00	

* MANDATORY ELECTRIC FEE - Add \$25.00 per showcase \$ _____

Add \$45.00 per accent cube for LED lighting \$ _____

SUBTOTAL \$ _____

8.375% SALES TAX \$ _____

TOTAL DUE \$ _____

COMPANY NAME _____

BOOTH NUMBER _____

**ONLINE ORDERING
AVAILABLE
VISIT AMERICANFIXTURE.COM**

ORDERS AND BOOTH LAYOUT DUE BY APRIL 29, 2022

American Fixture & Display Corp.

Phone: (718) 463-2176 • Fax: (718) 463-4302

Email: orders@americanfixture.com • Web: americanfixture.com

Please complete company name, credit card information and booth layout located on the final pages. This is required to process your order.

ECB A | ^ & d a e p A B | }) ^ & c j } A ^ A A A C I E E A ^ A @ . & e e A @ e A ^ A) A ^ * [c a e e a S ^ A U ^ a A O e Q e a i j } . A j A j . ^ A e A { [[c Q A [c A B A j A e Q e a j . E O E ^ i A e e A D e r c ^ A B A O e } j e s A O [i] E e Q e A e ^ A a d A e . a o s ^ A j | | ^ & c j } A @ A ^ A e j a A ^ { a i j } A e A e d e . E U ^ e ^ A [e A A ^ A] Q) ^ A i a ^ A [e A e e A] e a E A

Tower



**DELUXE
SHOWN HERE**

CHOICES:

- **STANDARD WHITE** Aluminum frame with a matte white formica exterior
- **DESIGNER** Aluminum frame with a textured gray formica exterior
- **DELUXE** Brushed gold frame with a glossy black formica exterior
- **ELITE** Brushed gold frame with a verdigris formica exterior

FEATURES:

- Halogen lighting
- LED lighting available for an additional \$45 per tower
- 6" canopy
- 3 adjustable glass shelves
- Clear glass on four sides
- Hinged framed door with lock
- 20" wide x 20" deep x 80" high
- 20" wide x 20" deep x 54" high glass display area



**DESIGNER
SHOWN HERE**

STYLE	QUANTITY	ADVANCED PRICE	PRICE FOR ORDERS RECEIVED AFTER 04/29/2022	SHOW SITE PRICE	TOTAL
STANDARD WHITE		\$400.00	\$475.00	\$600.00	
DESIGNER		\$400.00	\$475.00	\$600.00	
DELUXE		\$400.00	\$475.00	\$600.00	
ELITE		\$400.00	\$475.00	\$600.00	

* MANDATORY ELECTRIC FEE - Add \$25.00 per showcase \$ _____

Add \$45.00 per tower for LED lighting \$ _____

SUBTOTAL \$ _____

8.375% SALES TAX \$ _____

TOTAL DUE \$ _____

COMPANY NAME _____

BOOTH NUMBER _____

**ONLINE ORDERING
AVAILABLE**
 VISIT AMERICANFIXTURE.COM

ORDERS AND BOOTH LAYOUT DUE BY APRIL 29, 2022

American Fixture & Display Corp.

Phone: (718) 463-2176 • Fax: (718) 463-4302

Email: orders@americanfixture.com • Web: americanfixture.com

Please complete company name, credit card information and booth layout located on the final pages. This is required to process your order.

ECC A P d a e p A [] ^ & c j } A ^ A A C I E C A ^ A @ . & e ^ A @ A ^ A } A ^ * [c a e a s ^ A ^ a A C e @ a a j } . A j A ^ * ^ A A { [[c a [c a B A j A e @ a j ! . B O I ^ i a e a A d a r c i ^ A B O a] j e s A O [!] E C e A e i ^ a a A q A e . a c h ^ B j [^ & c j * A @ A ^ A j a A ^ { a a j * A a j A @ A j] [] i a e A e d e . E U ^ e ^ A [e ^ A ^ A ^] @) ^ A i a ^ A [c a e s ^] e a E A

Museum Pedestal



CHOICES:

- WHITE: Aluminum frame with matte white formica exterior
- DELUXE: Brushed gold frame with glossy black formica exterior
- BEIGE: Brushed gold frame with beige formica exterior

FEATURES:

- Halogen lighting
- LED lighting available for an additional \$60 per museum pedestal
- 8" canopy
- Glass doors with lock
- Storage area with lock
- 30" wide x 20" deep x 70" high
- 30" wide x 20" deep x 20" high glass display area

STYLE	QUANTITY	ADVANCED PRICE	PRICE FOR ORDERS RECEIVED AFTER 04/29/2022	SHOW SITE PRICE	TOTAL
White		\$445.00	\$520.00	\$645.00	
Deluxe		\$445.00	\$520.00	\$645.00	
Beige		\$445.00	\$520.00	\$645.00	

* MANDATORY ELECTRIC FEE - Add \$25.00 per showcase \$ _____

Add \$60.00 per museum pedestal for LED lighting \$ _____

SUBTOTAL \$ _____

8.375% SALES TAX \$ _____

TOTAL DUE \$ _____

COMPANY NAME _____

BOOTH NUMBER _____

**ONLINE ORDERING
AVAILABLE**
VISIT AMERICANFIXTURE.COM

ORDERS AND BOOTH LAYOUT DUE BY APRIL 29, 2022

American Fixture & Display Corp.

Phone: (718) 463-2176 • Fax: (718) 463-4302

Email: orders@americanfixture.com • Web: americanfixture.com

Please complete company name, credit card information and booth layout located on the final pages. This is required to process your order.

ECB A | ^ & d a e p A [] } ^ & c j } A ^ A A A C I E E A ^ A @ . s e e ^ A @ e A ^ A } A ^ * [c a e a s ^ A ^ a A O z @ e a j } . A / A ^ * ^ A A { [[c a [c ^ E A A I A e @ e a j] . E O E ^ i a e e A D e a r c ^ A B A O a] j e s A O [!] E E @ A e i ^ a A q A e . a c h ^ A [^ & c j } ^ @ A ^ A e j a A ^ { a c j } ^ A / A ^ A e j] [] i a e A e d e . E U ^ e ^ A [e ^ A ^ A ^ A] @) ^ A i a ^ A [e a e e A] e a E A

Boutique Case



**DELUXE BOUTIQUE WITH
SOLID BACK SHOWN HERE**

CHOICES:

- DESIGNER: Aluminum frame with textured gray formica exterior
- DELUXE: Brushed gold frame with glossy black formica exterior

FEATURES:

- Fluorescent lighting
- LED lighting available for an additional \$60 per boutique case
- 5" canopy
- Solid back or glass back
- 3 rows of adjustable glass shelves
- Glass doors with lock
- Storage area with lock
- 48" wide x 13" deep x 76" high
- 48" wide x 13" deep x 44" high glass display area

STYLE	QUANTITY		ADVANCED PRICE	PRICE FOR ORDERS RECEIVED AFTER 04/29/2022	SHOW SITE PRICE	TOTAL
	SOLID BACK	GLASS BACK				
Designer			\$475.00	\$550.00	\$675.00	
Deluxe			\$475.00	\$550.00	\$675.00	

* MANDATORY ELECTRIC FEE - Add \$25.00 per showcase \$ _____

Add \$60.00 per boutique case for LED lighting \$ _____

SUBTOTAL \$ _____

8.375% SALES TAX \$ _____

TOTAL DUE \$ _____

COMPANY NAME _____

BOOTH NUMBER _____

**ONLINE ORDERING
AVAILABLE
VISIT AMERICANFIXTURE.COM**

ORDERS AND BOOTH LAYOUT DUE BY APRIL 29, 2022

American Fixture & Display Corp.

Phone: (718) 463-2176 • Fax: (718) 463-4302

Email: orders@americanfixture.com • Web: americanfixture.com

Please complete company name, credit card information and booth layout located on the final pages. This is required to process your order.

ECB A P d a e p A () ^ & c j } A ^ A A A C I E E A ^ A @ . & e e ^ A @ e A ^ A } A ^ * [c a e e a A ^ A ^ A A O z Q e a a j } . A j A ^ . ^ A A { [[c Q A [c ^ E B A j A e Q e a j : • E Q E ^ i a e e A D e a r c i ^ A B A O e] j e s A O [i] E Q e A e i ^ A a A q A e • a c h ^ A j | | ^ & c j * A e A A A e j a A ^ { a a j * A e A A e A j | | [] i a e A e d e a • E U j ^ e e ^ A [e A A ^ A] @) ^ A i a ^ A [e A e e A] e a E A

Classic Case Line

FOR THE BEST SELECTION OF THE **CLASSIC CASE LINE**, ORDERS & BOOTH LAYOUTS MUST BE RECEIVED BY **APRIL 22, 2022**



V1 SHOWN HERE



V3 SHOWN HERE



V5 SHOWN HERE



V6 SHOWN HERE

TYPE	QUANTITY SILVER ANODIZED w/HALOGEN LIGHTS	PRICE*	LED LIGHTING				MR16 SIDE LIGHTS (\$50 PER CASE)		EXTRA SHELVES (\$10 PER CASE)	TOTAL	
			TOP ONLY \$45 PER CASE	TOP & SIDE LIGHTS \$130 PER CASE		GLASS SIDE	DOOR SIDE	GLASS SIDE			DOOR SIDE
				GLASS SIDE	DOOR SIDE						
V1		\$510.00									
V3		\$510.00									
V5		\$535.00									
V6		\$510.00									

*Add \$75 per case for all orders placed after APRIL 22, 2022; add \$125 for all orders placed at Show Site

** SEE NEXT PAGE FOR MORE DETAILS**

* MANDATORY ELECTRIC FEE - Add \$25.00 per showcase \$ _____

SUBTOTAL \$ _____

*LATE FEE (if applicable) \$ _____

8.375% SALES TAX \$ _____

TOTAL DUE \$ _____

COMPANY NAME _____

BOOTH NUMBER _____

CLASSIC CASE LINE ORDERS AND BOOTH LAYOUT DUE BY APRIL 22, 2022

American Fixture & Display Corp.

Phone: (718) 463-2176 • Fax: (718) 463-4302

Email: orders@americanfixture.com • Web: americanfixture.com

Please complete company name, credit card information and booth layout located on the final pages. This is required to process your order.

ECB A | ^ & d a e p A () } ^ & c j } A ^ A A - A A C I E E A ^ A @ . & e e ^ A @ e A ^ A } A ^ * [c a e e a s ^ A ^ A a A O e Q e a a j } . A j A s ^ * ^ A A A { [[c Q A [c ^ E B A j A e Q e a j ! • E Q E ^ i a e e A D e a c ^ i ^ A B A O e } j e s A O [!] E E Q e A e i ^ A a A q A e e a c h ^ B j | ^ & c j } ^ & c @ A ^ A e j a A A ^ { a a j } ^ A e j A e @ A e j | ! | i a e e A e e e a • E U ^ e e ^ A [e ^ A A ^ A } @) ^ A i a ^ A [e A e e A } e a E A

Classic Case Shelf Placement

V1

(interior height 65")

(pre-set to 17")
Change to _____ " {

(pre-set to 16")
Change to _____ " {

(pre-set to 16")
Change to _____ " {

(pre-set to 16")
Change to _____ " {



V3

(interior height 52")

(pre-set to 16 1/2")
Change to _____ " {

(pre-set to 17 1/2")
Change to _____ " {

(pre-set to 18")
Change to _____ " {



V5

(interior height 67")

(pre-set to 16 3/4")
Change to _____ " {

(pre-set to 16 3/4")
Change to _____ " {

(pre-set to 16 3/4")
Change to _____ " {

(pre-set to 16 3/4")
Change to _____ " {



V6

(interior height 67")

(pre-set to 17")
Change to _____ " {

(pre-set to 16 1/2")
Change to _____ " {

(pre-set to 16 1/2")
Change to _____ " {

(pre-set to 17")
Change to _____ " {



Each of the glass shelves on the Classic Cases is adjustable. The shelf rests are **preset** at our warehouse at the approximate intervals shown above.

If you would like us to alter the spacing of your shelves, please indicate your requirements above and submit this form along with your order **no later than ten (10) days prior to the start of the show**.

Please understand that due to time constraints during show set up, we are unable to make changes on-site.



SNEEZE GUARD

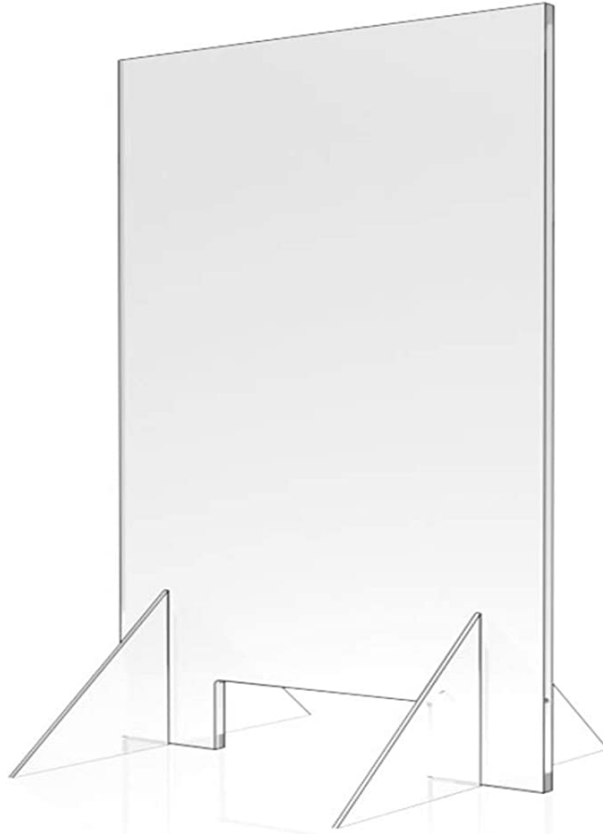

*DYfZYVh'Zcf'
d'UW'a Ybhicb'
nci f'g\ck WlgY
or table top'*

FEATURES:

- 24" Wide x 30" High
- Pass Through By 4" High X 12" Wide

QUANTITY	ADVANCED PRICE	PRICE FOR ORDERS RECEIVED AFTER 04/29/2022	TOTAL
	\$95.00	\$115.00	



SUBTOTAL \$ _____

8.375 % SALES TAX \$ _____

TOTAL DUE \$ _____

COMPANY NAME _____

BOOTH NUMBER _____

ORDERS AND BOOTH LAYOUT DUE BY APRIL 29, 2022

American Fixture & Display Corp.

Phone: (718) 463-2176 • Fax: (718) 463-4302

Email: orders@americanfixture.com • Web: americanfixture.com

If this product is not returned at the end of the event, you will automatically be charged \$150.00

Please complete company name, credit card information and booth layout located on the final pages. This is required to process your order.

Available Styles



FULL VISION SHOWCASE



HALF VISION SHOWCASE



QUARTER VISION SHOWCASE



CORNER SHOWCASE

Please complete company name, credit card information and booth layout located on the final pages. This is required to process your order.

Please note: Telephone orders not accepted.

CASES ARE RENTED FOR DISPLAY PURPOSES ONLY AND WE DO NOT WARRANT THE SAFETY OR SECURITY THEREOF. WE ARE NOT LIABLE FOR CONTENTS, DAMAGE OR BREAKAGE AFTER CASES HAVE BEEN DELIVERED.

Sample Layouts

10 FOOT X 10 FOOT CORNER BOOTHS

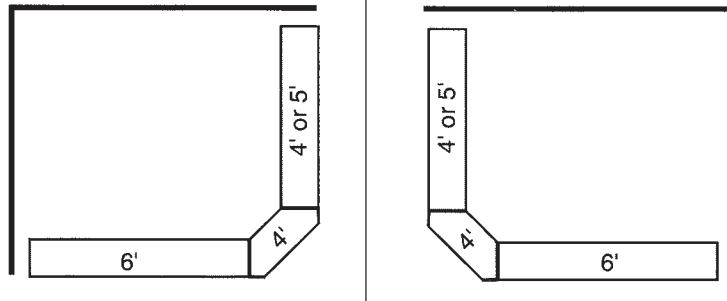

10 FOOT X 10 FOOT SINGLE BOOTHS

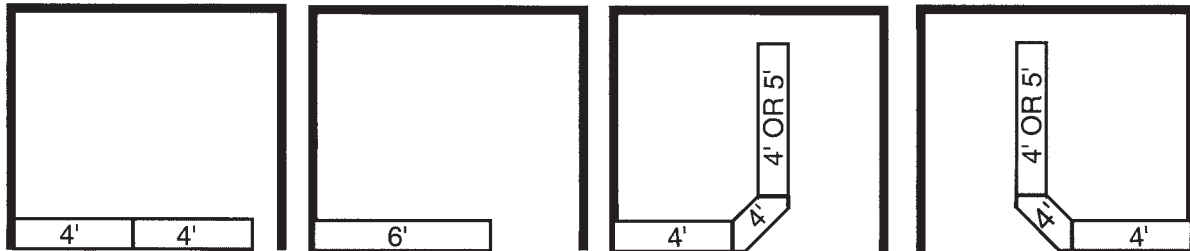

10 FOOT X 20 FOOT DOUBLE BOOTHS

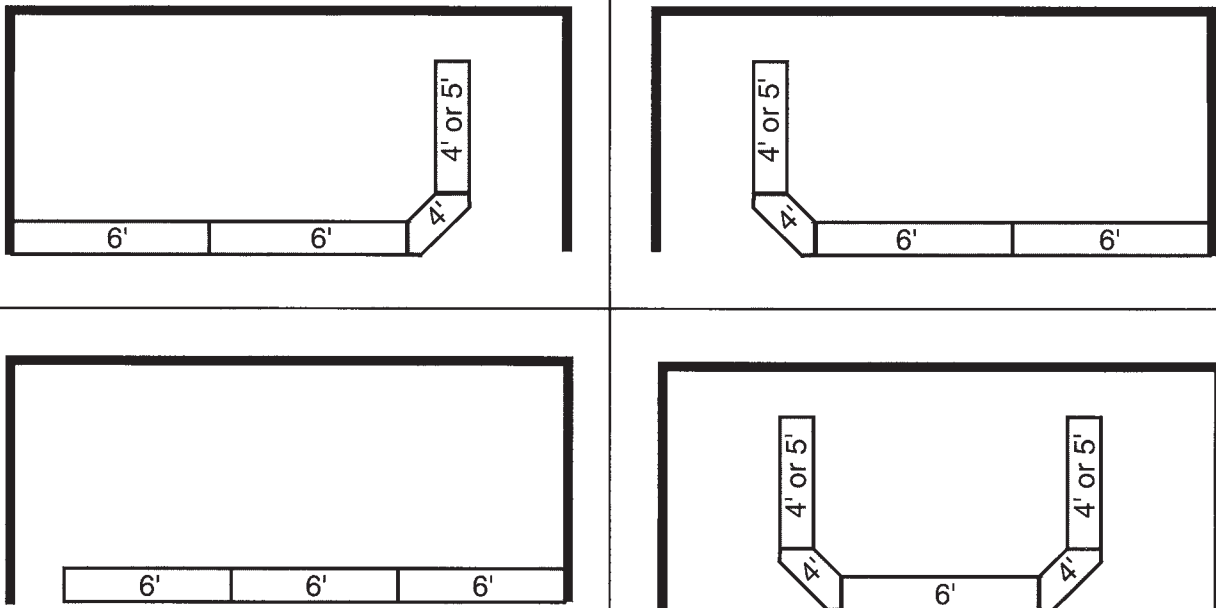

Please complete company name, credit card information and booth layout located on the final pages. This is required to process your order.

CASES ARE RENTED FOR DISPLAY PURPOSES ONLY AND WE DO NOT WARRANT THE SAFETY OR SECURITY THEREOF. WE ARE NOT LIABLE FOR CONTENTS, DAMAGE OR BREAKAGE AFTER CASES HAVE BEEN DELIVERED.

ELECTRICAL INFORMATION NON-LED LIGHTING

Standard White (Fluorescent)

4'	25 Watts
5'	30 Watts
6'	40 Watts
34" Corner	20 Watts

Designer & Deluxe (Fluorescent)

4'	25 Watts
5'	30 Watts
6'	40 Watts
34" Corner	20 Watts
42" Corner	30 Watts

Designer & Elite (Halogen)

4'	100 Watts
5'	120 Watts
6'	140 Watts
34" Corner	80 Watts
42" Corner	100 Watts

Tower (Halogen)

200 Watts

Museum Pedestal (Halogen)

300 Watts

Accent Cube (Halogen)

White & Designer	150 Watts
Deluxe & Elite	140 Watts

Boutique Case (Fluorescent)

84 Watts

Classic Case – Silver (Halogen & Spotlight)

V1, V3, V5	200 Watts
V6	150 Watts

ELECTRICAL INFORMATION

LED LIGHTING

Standard White

4'	33 Watts
5'	42 Watts
6'	49 Watts
34" Corner	26 Watts

Deluxe & Designer

4'	42 Watts
5'	48 Watts
6'	54 Watts
34" Corner	36 Watts
42" Corner	42 Watts

Elite

4'	12 Watts
5'	15 Watts
6'	17 Watts
34" Corner	9 Watts
42" Corner	12 Watts

Ultra Case – 6000K

4'	42 Watts
5'	48 Watts
6'	54 Watts
34" Corner	36 Watts
48" Corner	90 Watts

Ultra Case – 3000K

4'	12 Watts
5'	15 Watts
6'	17 Watts
34" Corner	9 Watts
48" Corner	16 Watts

Classic Case

V1, V3, V5	28 Watts
V6	21 Watts

Tower

100 Watts

Museum Pedestal

36 Watts

Accent Cube

24 Watts

Boutique

84 Watts

SHOWCASE ORDER FORM

Please complete the following information and submit it along with your showcase selections and booth layout diagram (previous page).

CONTACT INFORMATION

COMPANY NAME: _____

ADDRESS: _____

CITY, STATE, ZIP CODE: _____

POINT OF CONTACT NAME: _____

EMAIL ADDRESS: _____

PHONE: _____ FAX: _____

BOOTH NO(S): _____

PAYMENT INFORMATION

DISCOVER / AMEX / VISA / MC #: _____ EXP DATE: _____

NAME ON CARD: _____ SEC CODE: _____

SIGNATURE: _____ DATE: _____

ORDERS AND BOOTH LAYOUT DUE BY APRIL 29, 2022 | ULTRA & CLASSIC LINES DUE BY APRIL 22, 2022

TERMS AND CONDITIONS OF RENTAL

American Fixture & Display Corp. and AFD Delaware, Inc. (together, the "Company") shall not be liable for failure to deliver the displays ("Company's Rental Property") or delays occasioned by causes beyond its control, including, but not limited to, strikes, lockouts, fires, flood, hurricanes, war, acts of God, acts of terrorism, labor disputes, pandemics, epidemics, viruses, or delays or interruption of carriers and in no event shall be liable for consequential damages.

The Company shall have the right to charge the full rental price of the Company's Rental Property to the customer ("Lessee") on any orders (i) canceled after the deadline date; or (ii) that have been delivered to the location of the rental, regardless of whether the event takes place.

Glass shelves must be properly installed by Lessee and not overloaded with merchandise. To avoid breaking of shelves, personal injury and damage to merchandise, the Lessee must use reasonable discretion in the amount of weight placed on the glass shelves. Installation and loading of the glass shelves is beyond the Company's control and the Company shall not be responsible for broken glass, damage of merchandise or personal injury related thereto.

In the event of any damage to the Company Rental Property during the rental period, excluding normal wear and tear, the Lessee shall pay to Company, on demand, the full cost of repair or replacement of such damaged display cases. Lessee further agrees to accept full responsibility and liability, and Lessee shall indemnify, defend and hold harmless Company, for any injury to Lessee, for any damage to the property of Lessee, for any injury to any other person(s), for any damage to the property of any other person(s) and any other loss that may result through the use or misuse of the Company's Rental Property. Lessee agrees and acknowledges that Lessee is subject to additional charges if Lessee fails to return the Company's Rental Property to Company or fails to make the Company's Rental Property available to Company for pick-up at the time and date mutually agreed to by both parties.

Lessee agrees to accept full responsibility and liability, and shall indemnify, defend and hold harmless Company and its agents, employees, officers or directors from and against any and all liability, claims, demands (whether or not groundless, false, or fraudulent), costs, damages, losses, judgments, or awards, including legal and attorney fees, brought by a third party or parties and arising out of or in any way connected with any act or omission of Lessee or its employees or other persons.

The Company's Rental Property are rented for display purposes only and Company does not warrant the safety or security thereof. Company shall not be liable for contents, damage or breakage after the Company's Rental Property have been delivered.

Ultra Line



FULL VISION SHOWN HERE

ULTRA LINE FEATURES:

- LED lighting available in:
 - 3000K Yellow
 - 6000K White
- Aluminum frame
- Matte black exterior
- Glass sliding doors with lock
- Glass sides
- Rear storage area with lock available on half and quarter vision showcases only
- Available in 4', 5', and 6' lengths and corner cases
- Available in full, half, and quarter vision
- 41½" high and 20" deep (48" corner is 27 ½" deep)

SIZE	QUANTITY			3000K	6000K	ADVANCED PRICE	PRICE FOR ORDERS RECEIVED AFTER 04/22/2022	SHOW SITE PRICE	TOTAL
	FULL VISION	HALF VISION	QUARTER VISION						
4 FOOT						\$500.00	\$575.00	\$700.00	
5 FOOT						\$500.00	\$575.00	\$700.00	
6 FOOT						\$500.00	\$575.00	\$700.00	
34" CORNER						\$525.00	\$600.00	\$725.00	
48" CORNER						\$545.00	\$620.00	\$745.00	

* MANDATORY ELECTRIC FEE - Add \$25.00 per showcase \$ _____

SUBTOTAL \$ _____

8.375% SALES TAX \$ _____

TOTAL DUE \$ _____

COMPANY NAME _____

BOOTH NUMBER _____

ONLINE ORDERING AVAILABLE
VISIT AMERICANFIXTURE.COM

ORDERS AND BOOTH LAYOUT DUE BY APRIL 22, 2022

American Fixture & Display Corp.

Phone: (718) 463-2176 • Fax: (718) 463-4302

Email: orders@americanfixture.com • Web: americanfixture.com

Please complete company name, credit card information and booth layout located on the final pages. This is required to process your order.

© 2022 American Fixture & Display Corp. All rights reserved. This document is the property of American Fixture & Display Corp. and is to be used only for the purpose of ordering. No part of this document may be reproduced without the prior written permission of American Fixture & Display Corp.

CASES ARE RENTED FOR DISPLAY PURPOSES ONLY AND WE DO NOT WARRANT THE SAFETY OR SECURITY THEREOF. WE ARE NOT LIABLE FOR CONTENTS, DAMAGE OR BREAKAGE AFTER CASES HAVE BEEN DELIVERED.

Accent Cube



ACCENT CUBE FEATURES:

- LED lighting
- Aluminum frame
- Black exterior
- 18" wide x 18" deep x 70" high
- 18" wide x 18" deep x 18" high glass display area
- Hinged frameless glass door with lock
- Storage area with lock

QUANTITY	PRICE	PRICE FOR ORDERS RECEIVED AFTER 04/29/2022	SHOW SITE PRICE	TOTAL
	\$435.00	\$510.00	\$635.00	

* MANDATORY ELECTRIC FEE - Add \$25.00 per showcase \$ _____

SUBTOTAL \$ _____

8.375% SALES TAX \$ _____

TOTAL DUE \$ _____

COMPANY NAME _____

BOOTH NUMBER _____

ONLINE ORDERING AVAILABLE
VISIT AMERICANFIXTURE.COM

ORDERS AND BOOTH LAYOUT DUE BY APRIL 29, 2022

American Fixture & Display Corp.

Phone: (718) 463-2176 • Fax: (718) 463-4302

Email: orders@americanfixture.com • Web: americanfixture.com

Please complete company name, credit card information and booth layout located on the final pages. This is required to process your order.

ECB A P d a e p A [] } ^ & c j } A ^ A A C I E E A ^ A @ . & e e ^ A @ e A ^ A } A ^ [c a e a A ^ A ^ a A O z Q e a j } . A / A ^ { [[c Q [c ^ E A / A e Q e a j ; • E O E ^ i a e e A D e r c ^ A B A O e] j e s A O [!] E E e A e i ^ a A q A e • a c h ^ A [^ & c j * A @ A ^ A j a A ^ { a c j * A e A / A @ A j } [] i a e A e d e • E U ^ e ^ A [e A A ^ A] @) ^ A i a ^ A [e A e e A] e a E A

CASES ARE RENTED FOR DISPLAY PURPOSES ONLY AND WE DO NOT WARRANT THE SAFETY OR SECURITY THEREOF. WE ARE NOT LIABLE FOR CONTENTS, DAMAGE OR BREAKAGE AFTER CASES HAVE BEEN DELIVERED.

Tower



TOWER FEATURES:

- LED lighting
- Aluminum frame
- Black exterior
- 6" canopy
- 3 adjustable glass shelves
- Clear glass on four sides
- Hinged framed door with lock
- 20" wide x 20" deep x 80" high
- 20" wide x 20" deep x 54" high glass display area

QUANTITY	PRICE	PRICE FOR ORDERS RECEIVED AFTER 04/29/2022	SHOW SITE PRICE	TOTAL
	\$445.00	\$520.00	\$645.00	

* MANDATORY ELECTRIC FEE - Add \$25.00 per showcase \$ _____

SUBTOTAL \$ _____

8.375% SALES TAX \$ _____

TOTAL DUE \$ _____

COMPANY NAME _____

BOOTH NUMBER _____



ORDERS AND BOOTH LAYOUT DUE BY APRIL 29, 2022

American Fixture & Display Corp.

Phone: (718) 463-2176 • Fax: (718) 463-4302

Email: orders@americanfixture.com • Web: americanfixture.com

Please complete company name, credit card information and booth layout located on the final pages. This is required to process your order.

ECB A | ^ & d a e p A [] } ^ & c j } A ^ A A - A A C I E E A ^ A @ . s e e ^ A @ e A ^ A } A ^ * [c a e e a s ^ A ^ a A O z Q u a j } . A j A ^ . ^ A A { [[c Q A [c ^ E j A j A e Q u a j ! . E O E ^ i a e e j A d e r c ^ A B A O a] j e s A O [!] E E Q e A e ! ^ a a A q A e . a o s ^ A j | | ^ & c j * A e A e A e j a A ^ { a u j * A e j A e A e j } | [] i a e A e d e a . E U ^ e e ^ A j [e A A ^ A] @) ^ A j a ^ A j [e A e e A] e a E A

CASES ARE RENTED FOR DISPLAY PURPOSES ONLY AND WE DO NOT WARRANT THE SAFETY OR SECURITY THEREOF. WE ARE NOT LIABLE FOR CONTENTS, DAMAGE OR BREAKAGE AFTER CASES HAVE BEEN DELIVERED.

Museum Pedestal



MUSEUM PEDESTAL FEATURES:

- LED lighting
- Aluminum Frame
- Black exterior
- 8" canopy
- Glass doors with lock
- Storage area with lock
- 30" wide x 20" deep x 70" high
- 30" wide x 20" deep x 20" high glass display area

QUANTITY	PRICE	PRICE FOR ORDERS RECEIVED AFTER 04/29/2022	SHOW SITE PRICE	TOTAL
	\$505.00	\$580.00	\$705.00	

* MANDATORY ELECTRIC FEE - Add \$25.00 per showcase \$ _____

SUBTOTAL \$ _____

8.375% SALES TAX \$ _____

TOTAL DUE \$ _____

COMPANY NAME _____

BOOTH NUMBER _____



ORDERS AND BOOTH LAYOUT DUE BY APRIL 29, 2022

American Fixture & Display Corp.

Phone: (718) 463-2176 • Fax: (718) 463-4302

Email: orders@americanfixture.com • Web: americanfixture.com

Please complete company name, credit card information and booth layout located on the final pages. This is required to process your order.

(Small, illegible text, likely a barcode or tracking information)

Boutique Case



GLASS BACK SHOWN HERE

BOUTIQUE CASE FEATURES:

- LED lighting
- Aluminum Frame
- Black exterior
- 5" canopy
- Solid back or glass back
- 3 rows of adjustable glass shelves
- Glass doors with lock
- Storage area with lock
- 48" wide x 13" deep x 76" high
- 48" wide x 13" deep x 44" high glass display area

QUANTITY		PRICE	PRICE FOR ORDERS RECEIVED AFTER 04/29/2022	SHOW SITE PRICE	TOTAL
SOLID	GLASS				
		\$535.00	\$610.00	\$735.00	

* MANDATORY ELECTRIC FEE - Add \$25.00 per showcase \$ _____

SUBTOTAL \$ _____

8.375% SALES TAX \$ _____

TOTAL DUE \$ _____

COMPANY NAME _____

BOOTH NUMBER _____



ORDERS AND BOOTH LAYOUT DUE BY APRIL 29, 2022

American Fixture & Display Corp.

Phone: (718) 463-2176 • Fax: (718) 463-4302

Email: orders@americanfixture.com • Web: americanfixture.com

Please complete company name, credit card information and booth layout located on the final pages. This is required to process your order.

© 2022 American Fixture & Display Corp. All rights reserved. This document is the property of American Fixture & Display Corp. and is not to be distributed, copied, or used in any way without the express written consent of American Fixture & Display Corp. The information contained herein is for informational purposes only and does not constitute an offer or any other financial product. American Fixture & Display Corp. is not a financial institution and does not provide financial services. American Fixture & Display Corp. is not responsible for the accuracy or completeness of the information contained herein. American Fixture & Display Corp. is not liable for any damages, including consequential damages, arising from the use of this information. American Fixture & Display Corp. is not responsible for any errors or omissions in this document. American Fixture & Display Corp. is not responsible for any changes or updates to this document. American Fixture & Display Corp. is not responsible for any delays or interruptions in the delivery of this document. American Fixture & Display Corp. is not responsible for any loss of data or information. American Fixture & Display Corp. is not responsible for any unauthorized use or disclosure of this information. American Fixture & Display Corp. is not responsible for any misuse of this information. American Fixture & Display Corp. is not responsible for any reliance on this information. American Fixture & Display Corp. is not responsible for any actions taken based on this information. American Fixture & Display Corp. is not responsible for any consequences of any actions taken based on this information. American Fixture & Display Corp. is not responsible for any damages, including consequential damages, arising from the use of this information. American Fixture & Display Corp. is not responsible for any errors or omissions in this document. American Fixture & Display Corp. is not responsible for any changes or updates to this document. American Fixture & Display Corp. is not responsible for any delays or interruptions in the delivery of this document. American Fixture & Display Corp. is not responsible for any loss of data or information. American Fixture & Display Corp. is not responsible for any unauthorized use or disclosure of this information. American Fixture & Display Corp. is not responsible for any misuse of this information. American Fixture & Display Corp. is not responsible for any reliance on this information. American Fixture & Display Corp. is not responsible for any actions taken based on this information. American Fixture & Display Corp. is not responsible for any consequences of any actions taken based on this information.

CASES ARE RENTED FOR DISPLAY PURPOSES ONLY AND WE DO NOT WARRANT THE SAFETY OR SECURITY THEREOF. WE ARE NOT LIABLE FOR CONTENTS, DAMAGE OR BREAKAGE AFTER CASES HAVE BEEN DELIVERED.

SNEEZE GUARD

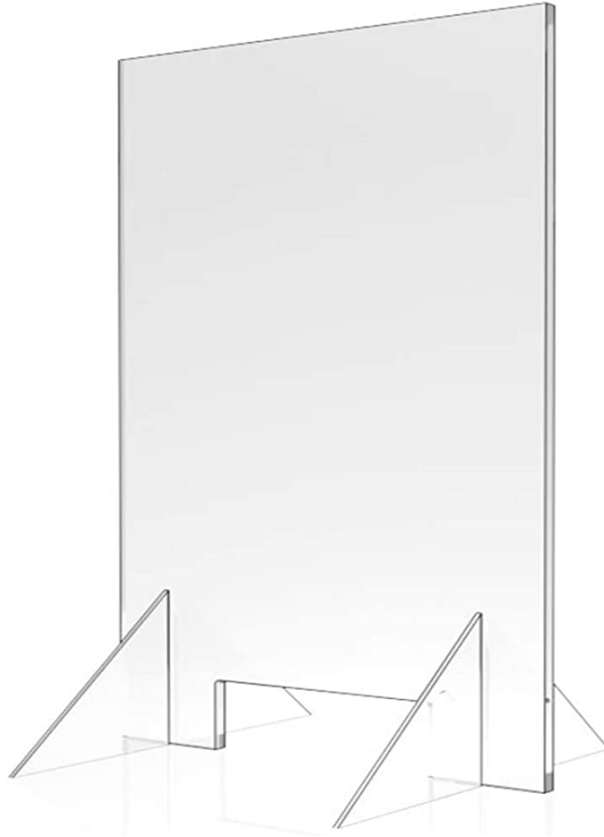

*Perfect for
placement on
your showcase
or table top*

FEATURES:

- 24" Wide x 30" High
- Pass Through By 4" High X 12" Wide

QUANTITY	ADVANCED PRICE	PRICE FOR ORDERS RECEIVED AFTER 04/29/22	TOTAL
	\$95.00	\$115.00	

SUBTOTAL \$ _____

8.375 % SALES TAX \$ _____

TOTAL DUE \$ _____

COMPANY NAME _____

BOOTH NUMBER _____

ORDERS AND BOOTH LAYOUT DUE BY APRIL 29, 2022

American Fixture & Display Corp.

Phone: (718) 463-2176 • Fax: (718) 463-4302

Email: orders@americanfixture.com • Web: americanfixture.com

If this product is not returned at the end of the event, you will automatically be charged \$150.00

Please complete company name, credit card information and booth layout located on the final pages. This is required to process your order.

Available Styles



FULL VISION SHOWCASE



HALF VISION SHOWCASE



QUARTER VISION SHOWCASE



CORNER SHOWCASE

Please complete company name, credit card information and booth layout located on the final pages. This is required to process your order.

CASES ARE RENTED FOR DISPLAY PURPOSES ONLY AND WE DO NOT WARRANT THE SAFETY OR SECURITY THEREOF. WE ARE NOT LIABLE FOR CONTENTS, DAMAGE OR BREAKAGE AFTER CASES HAVE BEEN DELIVERED.

Sample Layouts

10 FOOT X 10 FOOT CORNER BOOTHS

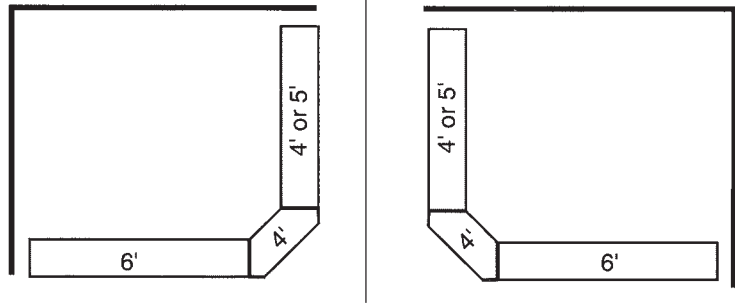

10 FOOT X 10 FOOT SINGLE BOOTHS

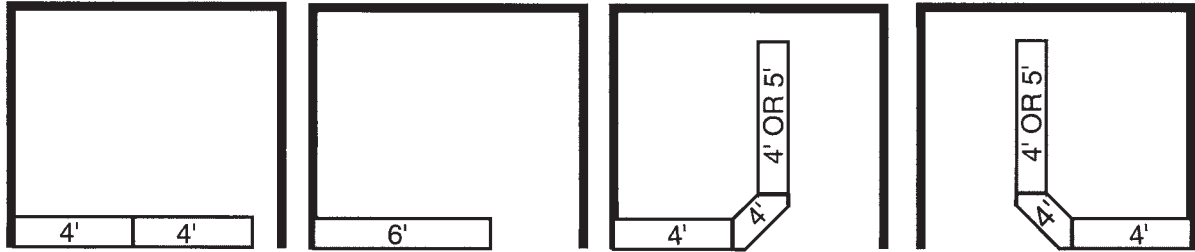

10 FOOT X 20 FOOT DOUBLE BOOTHS

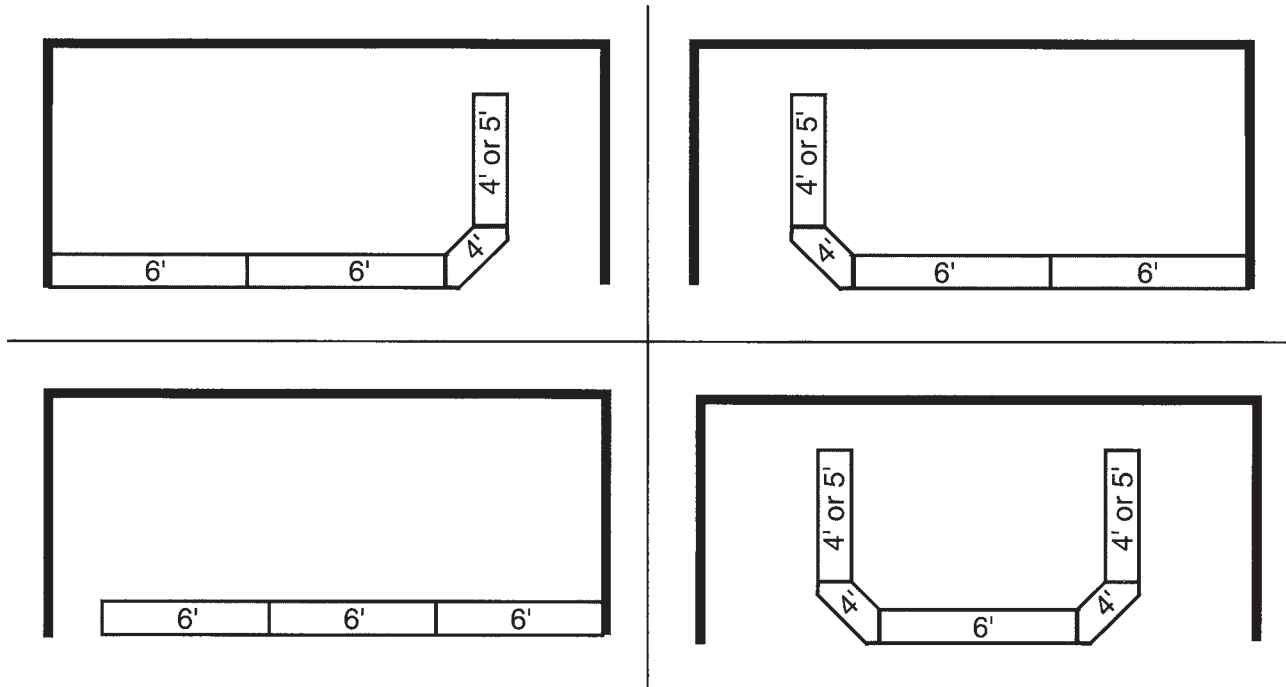

Please complete company name, credit card information and booth layout located on the final pages. This is required to process your order.

Electrical Details

Ultra Case – 6000K

4'	42 Watts
5'	48 Watts
6'	54 Watts
34" Corner	36 Watts
48" Corner	90 Watts

Ultra Case – 3000K

4'	12 Watts
5'	15 Watts
6'	17 Watts
34" Corner	9 Watts
48" Corner	16 Watts

Accent Cube

24 Watts

Tower

100 Watts

Museum Pedestal

36 Watts

Boutique Case

84 Watts

Please complete company name, credit card information and booth layout located on the final pages. This is required to process your order.

CASES ARE RENTED FOR DISPLAY PURPOSES ONLY AND WE DO NOT WARRANT THE SAFETY OR SECURITY THEREOF. WE ARE NOT LIABLE FOR CONTENTS, DAMAGE OR BREAKAGE AFTER CASES HAVE BEEN DELIVERED.

SHOWCASE ORDER FORM

Please complete the following information and submit it along with your showcase selections and booth layout diagram (previous page).

CONTACT INFORMATION

COMPANY NAME: _____

ADDRESS: _____

CITY, STATE, ZIP CODE: _____

POINT OF CONTACT NAME: _____

EMAILADDRESS: _____

PHONE: _____ FAX: _____

BOOTH NO(S): _____

PAYMENT INFORMATION

DISCOVER / AMEX / VISA / MC #: _____ EXP DATE: _____

NAME ON CARD: _____ SEC CODE: _____

SIGNATURE: _____ DATE: _____

ORDERS AND BOOTH LAYOUT DUE BY APRIL 29, 2022 | ULTRA LINE DUE BY APRIL 21, 2022

TERMS AND CONDITIONS OF RENTAL

American Fixture & Display Corp. and AFD Delaware, Inc. (together, the "Company") shall not be liable for failure to deliver the displays ("Company's Rental Property") or delays occasioned by causes beyond its control, including, but not limited to, strikes, lockouts, fires, flood, hurricanes, war, acts of God, acts of terrorism, labor disputes, pandemics, epidemics, viruses, or delays or interruption of carriers and in no event shall be liable for consequential damages.

The Company shall have the right to charge the full rental price of the Company's Rental Property to the customer ("Lessee") on any orders (i) canceled after the deadline date; or (ii) that have been delivered to the location of the rental, regardless of whether the event takes place.

Glass shelves must be properly installed by Lessee and not overloaded with merchandise. To avoid breaking of shelves, personal injury and damage to merchandise, the Lessee must use reasonable discretion in the amount of weight placed on the glass shelves. Installation and loading of the glass shelves is beyond the Company's control and the Company shall not be responsible for broken glass, damage of merchandise or personal injury related thereto.

In the event of any damage to the Company Rental Property during the rental period, excluding normal wear and tear, the Lessee shall pay to Company, on demand, the full cost of repair or replacement of such damaged display cases. Lessee further agrees to accept full responsibility and liability, and Lessee shall indemnify, defend and hold harmless Company, for any injury to Lessee, for any damage to the property of Lessee, for any injury to any other person(s), for any damage to the property of any other person(s) and any other loss that may result through the use or misuse of the Company's Rental Property. Lessee agrees and acknowledges that Lessee is subject to additional charges if Lessee fails to return the Company's Rental Property to Company or fails to make the Company's Rental Property available to Company for pick-up at the time and date mutually agreed to by both parties.

Lessee agrees to accept full responsibility and liability, and shall indemnify, defend and hold harmless Company and its agents, employees, officers or directors from and against any and all liability, claims, demands (whether or not groundless, false, or fraudulent), costs, damages, losses, judgments, or awards, including legal and attorney fees, brought by a third party or parties and arising out of or in any way connected with any act or omission of Lessee or its employees or other persons.

The Company's Rental Property are rented for display purposes only and Company does not warrant the safety or security thereof. Company shall not be liable for contents, damage or breakage after the Company's Rental Property have been delivered.